

**Includes 1 Year Access  
to 6 Practice Exams!**

See Page 6 for Details

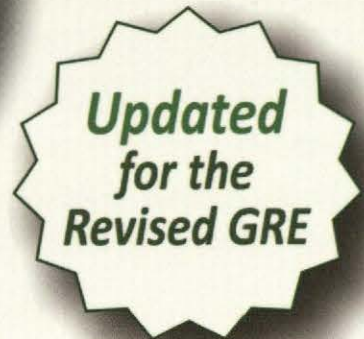

# Algebra

## GRE® STRATEGY GUIDE

Learn Using Superior Tools Developed by  
**Superior GRE Teachers**

- Scored in 99th percentile on the GRE
- Selected by rigorous face-to-face auditions
- Trained 100+ hours before teaching
- Paid up to 4x the industry standard

*"The precise breakdown of every topic was really helpful and easy to understand."*

**-Manhattan GRE Course Student**

**The Manhattan GRE Advantage:** Sophisticated Strategies For Top Scores

# g

## ALGEBRA

### GRE Math Preparation Guide

This guide covers algebra in all its many forms and disguises on the GRE, enabling students to master fundamental techniques and nuanced strategies to solve for every variety of unknown variable.

# 8 GUIDE INSTRUCTIONAL SERIES

---

g

## Math GRE Preparation Guides

### Algebra

(ISBN: 978-1-935707-47-9)

### Fractions, Decimals, & Percents

(ISBN: 978-1-935707-48-6)

### Geometry

(ISBN: 978-1-935707-49-3)

### Number Properties

(ISBN: 978-1-935707-50-9)

### Word Problems

(ISBN: 978-1-935707-54-7)

### Quantitative Comparisons & Data Interpretation

(ISBN: 978-1-935707-51-6)

## Verbal GRE Preparation Guides

### Reading Comprehension & Essays

(ISBN: 978-1-935707-52-3)

### Text Completion & Sentence Equivalence

(ISBN: 978-1-935707-53-0)



March 15<sup>th</sup>, 2011

Dear Student,

Thank you for picking up one of the Manhattan GRE Strategy Guides—we hope that it ends up being just what you need to prepare for the new GRE.

As with most accomplishments, there were many people involved in the book that you're holding. First and foremost is Zeke Vanderhoek, the founder of MG Prep. Zeke was a lone tutor in New York when he started the Company in 2000. Now, eleven years later, the Company has Instructors and offices nationwide and contributes to the studies and successes of thousands of students each year.

Our Manhattan GRE Strategy Guides are based on the continuing experiences of our Instructors and our students. On the Company side, we are indebted to many of our Instructors, including but not limited to Roman Altshuler, Chris Berman, Faruk Bursal, Jen Dziura, Dmitry Farber, Stacey Koprince, David Mahler, Seb Moosapoor, Stephanie Moyerman, Chris Ryan, Michael Schwartz, Tate Shafer, Emily Sledge, Tommy Wallach, and Ryan Wessel, all of whom either wrote or edited the books to their present form. Dan McNaney and Cathy Huang provided their formatting expertise to make the books as user-friendly as possible. Last, many people, too numerous to list here but no less appreciated, assisted in the development of the online resources that accompany this guide.

At Manhattan GRE, we continually aspire to provide the best Instructors and resources possible. We hope that you'll find our dedication manifest in this book. If you have any comments or questions, please e-mail me at [dan@manhattangre.com](mailto:dan@manhattangre.com). I'll be sure that your comments reach our curriculum team—and I'll read them too.

Best of luck in preparing for the GRE!

Sincerely,

Dan Gonzalez  
Managing Director  
Manhattan GRE

<b>1. INTRODUCTION &amp; THE REVISED GRE</b>	<b>11</b>
<hr/>	
<b>2. EQUATIONS</b>	<b>27</b>
<hr/>	
In Action Problems	45
Solutions	47
<b>3. QUADRATIC EQUATIONS</b>	<b>51</b>
<hr/>	
In Action Problems	73
Solutions	75
<b>4. INEQUALITIES &amp; ABSOLUTE VALUES</b>	<b>79</b>
<hr/>	
In Action Problems	99
Solutions	101
<b>5. FORMULAS &amp; FUNCTIONS</b>	<b>103</b>
<hr/>	
In Action Problems	117
Solutions	119
<b>6. DRILL SETS</b>	<b>123</b>
<hr/>	
Solutions	
<b>7. PRACTICE QUESTION SETS</b>	<b>145</b>
<hr/>	
Problem Sets	147
Solutions	161

**TABLE OF CONTENTS**



g

**Chapter 1**  
*of*

ALGEBRA

**INTRODUCTION &  
THE REVISED GRE**

## In This Chapter . . .

---

**g**

- Introduction, and How to Use Manhattan GRE's Strategy Guides
- The Revised GRE
- Question Formats in Detail

## Introduction, and How to Use Manhattan GRE's Strategy Guides

We know that you're looking to succeed on the GRE so that you can go to graduate school and do the things you want to do in life.

We also know that you might not have done math since high school, and that you may never have learned words like “adumbrate” or “sangfroid.” We know that it's going to take hard work on your part to get a top GRE score, and that's why we've put together the only set of books that will take you from the basics all the way up to the material you need to master for a near-perfect score, or whatever your score goal may be. You've taken the first step. Now it's time to get to work!

### How to Use These Materials

Manhattan GRE's materials are comprehensive. But keep in mind that, depending on your score goal, it may not be necessary to “get” absolutely everything. Grad schools only see your overall Quantitative, Verbal, and Writing scores—they don't see exactly which strengths and weaknesses went into creating those scores.

You may be enrolled in one of our courses, in which case you already have a syllabus telling you in what order you should approach the books. But if you bought this book online or at a bookstore, feel free to approach the books—and even the chapters within the books—in whatever order works best for you. *For the most part, the books, and the chapters within them, are independent; you don't have to master one section before moving on to the next.* So if you're having a hard time with something in particular, you can make a note to come back to it later and move on to another section. Similarly, it may not be necessary to solve every single practice problem for every section. As you go through the material, continually assess whether you understand and can apply the principles in each individual section and chapter. The best way to do this is to solve the Check Your Skills and Practice Problems throughout. If you're confident you have a concept or method down, feel free to move on. If you struggle with something, make note of it for further review. Stay active in your learning and oriented toward the test—it's easy to read something and think you understand it, only to have trouble applying it in the 1–2 minutes you have to solve a problem.

### Study Skills

As you're studying for the GRE, try to integrate your learning into your everyday life. For example, vocabulary is a big part of the GRE, as well as something you just can't “cram” for—you're going to want to do at least a little bit of vocab every day. So, try to learn and internalize a little bit at a time, switching up topics often to help keep things interesting.

Keep in mind that, while many of your study materials are on paper (including ETS's most recent source of official GRE questions, *The Official Guide to the GRE revised General Test*), your exam will be administered on a computer. Because this is a computer-based test, you will NOT be able to underline portions of reading passages, write on diagrams of geometry figures, or otherwise physically mark up problems. So get used to this now. Solve the problems in these books on scratch paper. (Each of our books talks specifically about what to write down for different problem types).

Again, as you study stay focused on the test-day experience. As you progress, work on timed drills and sets of questions. Eventually, you should be taking full practice tests (available at [www.manhattangre.com](http://www.manhattangre.com)) under actual timed conditions.



## The Revised GRE

As of August 1, 2011, the Quantitative and Verbal sections of the GRE will undergo a number of changes. The actual body of knowledge being tested won't change, but the *way* it is tested will. Here's a brief summary of what to expect, followed by a more comprehensive assessment of the new exam.

Overall, the general format of the test will change. The length of the test will increase from about 3.5 hours to about 4 hours. There will be two scored math sections and two scored verbal sections rather than one of each, and a new score scale of 130–170 will be used in place of the old 200–800 scale. More on this later.

The Verbal section of the GRE will change dramatically. The Analogies and Antonym questions will disappear. The Sentence Completions and Reading Comprehension will remain, to be expanded and remixed in a few new ways. Vocabulary will still be important, but only in the context of complete sentences. That is, you'll no longer have to worry about vocabulary words standing alone. So for those who dislike learning vocabulary words, the changes will provide partial relief. For those who were looking forward to getting lots of points just for memorizing words, the Manhattan GRE verbal strategy guides will prepare you for the shift.

The Quant section of the GRE prior to August 1, 2011 is composed of multiple choice problems, Quantitative Comparisons, and Data Interpretation questions (which are really a subset of multiple choice problems). The revised test will contain two new problem formats in addition to the current problem formats. However, the type of math, and the difficulty of the math, will remain unchanged.

Additionally, a small four-function calculator with a square root button will appear on-screen. Many test takers will rejoice at the advent of this calculator! It is true that the GRE calculator will reduce emphasis on computation—but look out for problems, such as percents questions with tricky wording, that are likely to foil those who rely on the calculator too much. *In short, the calculator may make your life a bit easier from time to time, but you will never need the calculator to solve a problem.*

Finally, don't worry about whether these new problem types are “harder” or “easier.” You are being judged against other test takers, all of whom are in the same boat. So if the new formats are harder, they are harder for other test takers as well.

### Exam Structure

The revised test has six sections. You will get a ten-minute break between the third and fourth sections and a one-minute break between the others. The Analytical Writing section is always first. The other five sections can be seen in any order and will include:

- Two Verbal Reasoning sections (approximately 20 questions each in exactly 30 minutes per section)
- Two Quantitative Reasoning sections (approximately 20 questions each in exactly 35 minutes per section)
- Either an “unscored” section or a “research” section

An unscored section will look just like a third Verbal or Quantitative Reasoning section, and you will not be told which of them doesn't count. If you get a research section, it will be identified as such.

	Section Type	# Questions	Time	Scored?
	Analytical Writing	2 essays	30 minutes each	Yes
	Verbal #1	Approx. 20	30 minutes	Yes
	Quantitative #1	Approx. 20	35 minutes	Yes
10 min break →	Verbal #2	Approx. 20	30 minutes	Yes
	Quantitative #2	Approx. 20	35 minutes	Yes
one or the other, but not both {	Unscored Section (verbal or quant)	Approx. 20	30 or 35 min	No
	Research Section	Varies	Varies	No

Later in the chapter, we'll look at all the question formats in detail.

## Using the Calculator

The addition of a small, four-function calculator with a square root button means that those taking the revised test can forget re-memorizing their times tables or square roots. However, the calculator is not a cure-all; in many problems, the difficulty is in figuring out what numbers to put into the calculator in the first place. In some cases, using a calculator will actually be less helpful than doing the problem some other way. Let's look at an example:

If  $x$  is the remainder when  $(11)(7)$  is divided by 4 and  $y$  is the remainder when  $(14)(6)$  is divided by 13, what is the value of  $x + y$ ?

**Solution:** This problem is designed so that the calculator won't tell the whole story. Certainly the calculator will tell us that  $11 \times 7 = 77$ . When you divide 77 by 4, however, the calculator yields an answer of 19.25. The remainder is *not* 0.25 (a remainder is always a whole number).

You might just go back to your pencil and paper, and find the largest multiple of 4 that is less than 77. Since 4 DOES go into 76, we can conclude that 4 would leave a remainder of 1 when dividing into 77. (Notice that we don't even need to know how many times 4 goes into 76, just that it goes in. One way to mentally "jump" to 76 is to say, 4 goes into 40, so it goes into 80 ... that's a bit too big, so take away 4 to get 76.) You could also multiply the leftover 0.25 times 4 (the divisor) to find the remainder of 1.

However, it is also possible to use the calculator to find a remainder. Divide 77 by 4 to get 19.25. Thus, 4 goes into 77 nineteen times, with a remainder left over. Now use your calculator to multiply 19 (JUST 19, not 19.25) by 4. You will get 76. The remainder is  $77 - 76 = 1$ . Therefore,  $x = 1$ .

Use the same technique to find  $y$ . Multiply  $14 \times 6$  to get 84. Divide 84 by 13 to get 6.46... Ignore everything after the decimal, and just multiply 6 by 13 to get 78. The remainder is therefore  $84 - 78 = 6$ . Therefore,  $y = 6$ .

Since we are looking for  $x + y$  and  $1 + 6 = 7$ , the answer is 7.

You can see that blind faith in the calculator can be dangerous. Use it responsibly! And this leads us to...

### **Practice Using the Calculator!**

On the new GRE, the on-screen calculator will slow you down or lead to incorrect answers if you're not careful! If you plan to use the thing on test day (which you should), you'll want to practice first.

We have created an online practice calculator for your use. To access this calculator, go to [www.manhattangre.com](http://www.manhattangre.com) and sign in to the student center using the instructions on the "How to Access Your Online Student Center" page found at the front of this book.

In addition to the calculator, you will see instructions for how to use the calculator. Be sure to read these instructions and work through the associated exercises. Throughout our math books, you will see the



symbol. This symbol means "use the calculator here!" As much as possible, have the online practice calculator up and running during your review of our math books. You'll have the chance to use the on-screen calculator when you take our practice exams as well.

### **Navigating the Questions in a Section**

Another change for test takers on the new GRE is the ability to move freely around the questions in a section... you can go forward and backward one-by-one and can even jump directly to any question from the "review list." The review list provides a snapshot of which questions you have answered, which ones you have tagged for "mark and review," and which are incomplete, either because you didn't select enough answers or because you selected too many (that is, if a number of choices is specified by the question). You should double-check the review list for completion if you finish the section early. Using the review list feature will take some practice as well, which is why we've built it into our online practice exams. Here's some introductory advice.

The majority of test takers will be pressed for time. Thus, for most of you, it won't be feasible to "go back to" multiple problems at the end of the section. Generally, if you can't get a question the first time, you won't be able to get it the second time around either. With this in mind, here's how we recommend using the new review list feature.

1. Do the questions in order as they appear.
2. When you encounter a difficult question, do your best to eliminate answer choices you know are wrong.
3. If you're not sure of an answer, take an educated guess from the choices remaining. Do NOT skip it and hope to return to it later.

4. Using the “mark” button at the top of the screen, mark up to three questions per section that you think you might be able to solve with more time. Mark a question only after you have taken an educated guess.
5. If you have time at the end of the section, click on the review list, identify any questions you’ve marked and return to them. If you do not have any time remaining, you will have already taken good guesses at the tough ones.

What you want to avoid is “surfing”—clicking forward and backward through the questions searching for the easy ones. This will eat up valuable time. Of course, you’ll want to move through the tough ones quickly if you can’t get them, but try to avoid skipping stuff.

Again, all of this will take practice. Use our practice exams to fine-tune your approach.

## Scoring

Two things have changed about the scoring of the Verbal Reasoning and Quantitative Reasoning sections: (1) how individual questions influence the score and (2) the score scale itself.

For both the Verbal Reasoning and Quantitative Reasoning sections, you will receive a raw score, which is simply how many questions you answered correctly. Your raw score is converted to a scaled score, accounting for the difficulties of the specific questions you actually saw.

The old GRE was question-adaptive, meaning that your answer to each question (right or wrong) determined, at least somewhat, the questions that followed (harder or easier). Because you had to commit to an answer to let the algorithm do its thing, you weren’t allowed to skip questions or go back to change answers. On the revised GRE, the adapting will occur from section to section (e.g., if you do well on the first verbal section, you will get a harder second verbal section) rather than from question to question. The only change test takers will notice is one most will welcome: you can now move freely about the questions in a section, coming back to tough questions later, changing answers after “ah-ha!” moments, and generally managing your time more flexibly.

The scores for the revised GRE Quantitative Reasoning and Verbal Reasoning will be reported on a 130 to 170 scale in 1-point increments, whereas the old score reporting was on a 200 to 800 scale in 10-point increments. You will receive one 130–170 score for verbal and a separate 130–170 score for quant. If you are already putting your GRE math skills to work, you may notice that there are now 41 scores possible ( $170 - 130$ , then add one before you’re done), whereas before there were 61 scores possible ( $[800 - 200]/10$ , then add one before you’re done). In other words, a 10 point difference on the old score scale actually indicated a smaller performance differential than a 1 point difference on the new scale. However, the GRE folks argue that perception is reality: the difference between 520 and 530 on the old scale could simply seem greater than the difference between 151 and 152 on the new scale. If that’s true, then this change will benefit test-takers, who won’t be unfairly compared by schools for minor differences in performance. If not true, then the change will be moot.

## Important Dates

Registration for the GRE revised General Test opens on March 15, 2011, and the first day of testing with the new format is August 1, 2011.

Perhaps to encourage people to take the revised exam, rather than rushing to take the old exam before the change or waiting “to see what happens” with the new exam long after August 1, 2011, ETS is offering a 50% discount on the test fee for anyone who takes the revised test from August 1 through September 30, 2011. Scores for people who take

the revised exam in this discount period will be sent starting in mid- to late-November. This implies that you may have to wait up to 3.5 months to get your score during this rollout period!

By December 2011, ETS expects to resume normal score reporting schedules: score reports will be sent a mere 10-15 days after the test date.

**IMPORTANT: If you need GRE scores before mid-November 2011 to meet a school deadline, take the “old” GRE no later than July 31, 2011! Waiting to take the revised test not only would require you to study for a different test, but also would delay your score reporting.**

## Question Formats in Detail

### Essay Questions

The Analytical Writing section consists of two separately timed 30-minute tasks: Analyze an Issue and Analyze an Argument. As you can imagine, the 30-minute time limit implies that you aren't aiming to write an essay that would garner a Pulitzer Prize nomination, but rather to complete the tasks adequately and according to the directions. Each essay is scored separately, but your reported essay score is the average of the two rounded up to the next half-point increment on a 0 to 6 scale.

**Issue Task**—This essay prompt will present a claim, generally one that is vague enough to be interpreted in various ways and discussed from numerous perspectives. Your job as a test taker is to write a response discussing the extent to which you agree or disagree and support your position. Don't sit on the fence—pick a side!

For some examples of Issue Task prompts, visit the GRE website here:

[http://www.ets.org/gre/revised\\_general/prepare/analytical\\_writing/issue/pool](http://www.ets.org/gre/revised_general/prepare/analytical_writing/issue/pool)

**Argument Task**—This essay prompt will be an argument comprised of both a claim(s) and evidence. Your job is to dispassionately discuss the argument's structural flaws and merits (well, mostly the flaws). Don't agree or disagree with the argument—evaluate its logic.

For some examples of Argument Task prompts, visit the GRE website here:

[http://www.ets.org/gre/revised\\_general/prepare/analytical\\_writing/argument/pool](http://www.ets.org/gre/revised_general/prepare/analytical_writing/argument/pool)

### Verbal: Reading Comprehension Questions

Standard 5-choice multiple choice reading comprehension questions will continue to appear on the new exam. You are likely familiar with how these work. Let's take a look at two *new* reading comprehension formats that will appear on the new test.

*Select One or More Answer Choices and Select-in-Passage*

For the question type, “Select One or More Answer Choices,” you are given three statements about a passage and asked to “select all that apply.” Either one, two, or all three can be correct (there is no “none of the above” option). There is no partial credit; you must select all the correct choices and none of the incorrect choices.

*Strategy Tip: On “Select One or More Answer Choices,” don’t let your brain be tricked into telling you “Well, if two of them have been right so far, the other one must be wrong,” or any other arbitrary idea about how many of the choices “should” be correct. Make sure to consider each choice independently! You cannot use “Process of Elimination” the same way as you do on “normal” multiple-choice questions.*

For the question type “Select-in-Passage,” you are given an assignment such as “Select the sentence in the passage that explains why the experiment’s results were discovered to be invalid.” Clicking anywhere on the sentence in the passage will highlight it. (As with any GRE question, you will have to click “Confirm” to submit your answer, so don’t worry about accidentally selecting the wrong sentence due to a slip of the mouse.)

*Strategy Tip: On “Select-in-Passage,” if the passage is short, consider numbering each sentence (that is, writing 1 2 3 4 on your paper) and crossing off each choice as you determine that it isn’t the answer. If the passage is long, you might write a number for each paragraph (I, II, III), and tick off each number as you determine that the correct sentence is not located in that paragraph.*

Now let’s give these new question types a try!

*The sample questions below are based on this passage:*

Physicist Robert Oppenheimer, director of the fateful Manhattan Project, said “It is a profound and necessary truth that the deep things in science are not found because they are useful; they are found because it was possible to find them.” In a later address at MIT, Oppenheimer presented the thesis that scientists could be held only very nominally responsible for the consequences of their research and discovery. Oppenheimer asserted that ethics, philosophy, and politics have very little to do with the day-to-day work of the scientist, and that scientists could not rationally be expected to predict all the effects of their work. Yet, in a talk in 1945 to the Association of Los Alamos Scientists, Oppenheimer offered some reasons why the Manhattan project scientists built the atomic bomb; the justifications included “fear that Nazi Germany would build it first” and “hope that it would shorten the war.”

For question #1, consider each of the three choices separately and select all that apply.

1. The passage implies that Robert Oppenheimer would most likely have agreed with which of the following views:

- A Some scientists take military goals into account in their work
- B Deep things in science are not useful
- C The everyday work of a scientist is only minimally involved with ethics

2. Select the sentence in which the writer implies that Oppenheimer has not been consistent in his view that scientists have little consideration for the effects of their work.

*[Here, you would highlight the appropriate sentence with your mouse. Note that there are only four options.]*

## Solutions:

1. {A, C} Oppenheimer says in the last sentence that one of the reasons the bomb was built was scientists' "hope that it would shorten the war." Thus, Oppenheimer would likely agree with the view that "Some scientists take military goals into account in their work." B is a trap answer using familiar language from the passage. Oppenheimer says that scientific discoveries' possible usefulness is not why scientists make discoveries; he does not say that the discoveries aren't useful. Oppenheimer specifically says that ethics has "very little to do with the day-to-day work of the scientist," which is a good match for "only minimally involved with ethics."

*Strategy Tip: On "Select One or More Answer Choices," write ABC on your paper and mark each choice with a check, an X, or a symbol such as - if you're not sure. This should keep you from crossing out all three choices and having to go back (at least one of the choices must be correct). For example, let's say that on a different question you had marked*

- A. X  
B. X  
C. -

The one you weren't sure about, (C), is likely to be correct, since there must be at least one correct answer.

2. The correct sentence is: **Yet, in a talk in 1945 to the Association of Los Alamos Scientists, Oppenheimer offered some reasons why the Manhattan project scientists built the atomic bomb; the justifications included "fear that Nazi Germany would build it first" and "hope that it would shorten the war."** The word "yet" is a good clue that this sentence is about to express a view contrary to the views expressed in the rest of the passage.

## Verbal: Text Completion Questions

Text Completions are the new, souped-up Sentence Completions. They can consist of 1–5 sentences with 1–3 blanks. When Text Completions have two or three blanks, you will select words for those blanks independently. There is no partial credit; you must make every selection correctly.

Because this makes things a bit harder, the GRE has kindly reduced the number of possible choices per blank from five to three. Here is an old two-blank Sentence Completion, as it would appear on the old GRE:

*Old Format:*

Leaders are not always expected to \_\_\_\_\_ the same rules as are those they lead; leaders are often looked up to for a surety and presumption that would be viewed as \_\_\_\_\_ in most others.

- A. obey ... avarice  
B. proscribe ... insalubriousness  
C. decree ... anachronism  
D. conform to ... hubris  
E. follow ... eminence

And here's how this same sentence would appear on the new exam.

*New Format:*

Leaders are not always expected to (i) \_\_\_\_\_ the same rules as are those they lead; leaders are often looked up to for a surety and presumption that would be viewed as (ii) \_\_\_\_\_ in most others.

Blank (i)	Blank (ii)
decree	hubris
proscribe	avarice
conform to	anachronism

On the new GRE, you will select your two choices by actually clicking and highlighting the words you want.

**Solution:**

In the first blank, we need a word similar to “follow.” In the second blank, we need a word similar to “arrogant.” Only choice D works in the old format; in the new format, the answer is still “conform to” and “hubris,” but you’ll make the two choices separately.

Note that in the “Old Format” question, if you knew that you needed a word in the second blank that meant something like “arrogant,” and you knew that “hubris” was the only word in the second column with the correct meaning, you could pick correct answer choice D without even considering the first word in each pair. In the new format, this strategy is no longer available to us.

Also note that, in the “Old Format” question, “obey,” “conform to,” and “follow” mean basically the same thing. On the new GRE, this can’t happen: since you select each word independently, no two choices can be synonyms (otherwise, there would be two correct answers).

*Strategy Tip: As on the old GRE, do NOT look at the answer choices until you’ve decided for yourself, based on textual clues actually written in the sentence, what kind of word needs to go in each blank. Only then should you look at the choices and eliminate those that are not matches.*

Let’s try an example with three blanks.

For Kant, the fact of having a right and having the (i) \_\_\_\_\_ to enforce it via coercion cannot be separated, and he asserts that this marriage of rights and coercion is compatible with the freedom of everyone. This is not at all peculiar from the standpoint of modern political thought—what good is a right if its violation triggers no enforcement (be it punishment or (ii) \_\_\_\_\_)? The necessity of coercion is not at all in conflict with the freedom of everyone, because this coercion only comes into play when someone has (iii) \_\_\_\_\_ someone else.

Blank (i)	Blank (ii)	Blank (iii)
technique	amortization	questioned the hypothesis of
license	reward	violated the rights of
prohibition	restitution	granted civil liberties to



**Solution:**

In the first sentence, use the clue “he asserts that this marriage of rights and coercion is compatible with the freedom of everyone” to help fill in the first blank. Kant believes that “coercion” is “married to” rights and is compatible with freedom for all. So we want something in the first blank like “right” or “power.” Kant believes that rights are meaningless without enforcement. Only the choice “license” can work (while a “license” can be physical, like a driver’s license, “license” can also mean “right”).

The second blank is part of the phrase “punishment or \_\_\_\_\_,” which we are told is the “enforcement” resulting from the violation of a right. So the blank should be something, other than punishment, that constitutes enforcement against someone who violates a right. (More simply, it should be something bad!) Only “restitution” works. Restitution is compensating the victim in some way (perhaps monetarily or by returning stolen goods).

In the final sentence, “coercion only comes into play when someone has \_\_\_\_\_ someone else.” Throughout the text, “coercion” means enforcement against someone who has violated the rights of someone else. The meaning is the same here. The answer is “violated the rights of.”

The complete and correct answer is this combination:

Blank (i)  
license

Blank (ii)  
restitution

Blank (iii)  
violated the rights of

In theory, there are  $3 \times 3 \times 3 = 27$  possible ways to answer a 3-blank Text Completion—and only one of those 27 ways is correct. The guessing odds will go down, but don’t be intimidated. Just follow the basic process: come up with your own filler for each blank, and match to the answer choices. If you’re confused by this example, don’t worry! We’ll start from the beginning in our *Text Completion & Sentence Equivalence* strategy guide.

*Strategy Tip: As on the old GRE, do NOT “write your own story.” The GRE cannot give you a blank without also giving you a clue, physically written down in the passage, telling you what kind of word or phrase MUST go in that blank. Find that clue. You should be able to give textual evidence for each answer choice you select.*

## Verbal: Sentence Equivalence Questions

In this question type, you are given one sentence with a single blank. There are six answer choices, and you are asked to pick TWO choices that fit the blank and are alike in meaning.

Of the new question types, this one depends the most on vocabulary and also yields the most to strategy.

No partial credit is given on Sentence Equivalence; both correct answers must be selected. When you pick two of six choices, there are 15 possible combinations of choices, and only one is correct. However, this is not nearly as daunting as it sounds.

Think of it this way—if you have six choices, but the two correct ones must be “similar in meaning,” then you have, at most, three possible PAIRS of choices. Maybe fewer, since not all choices are guaranteed to have a “partner.” If you can match up the “pairs,” you can seriously narrow down your options.

Here is a sample set of answer choices:

- A tractable
- B taciturn
- C arbitrary
- D tantamount
- E reticent
- F amenable

We haven't even given you the question here, because we want to point out how much you can do with the choices alone, if you have studied vocabulary sufficiently.

TRACTABLE and AMENABLE are synonyms (tractable, amenable people will do whatever you want them to do). TACITURN and RETICENT are synonyms (both mean "not talkative"). ARBITRARY (based on one's own will) and TANTAMOUT (equivalent) are not similar in meaning and therefore cannot be a pair. Therefore, the ONLY possible answers are {A, F} and {B, E}. We have improved our chances from 1 in 15 to a 50/50 shot without even reading the question!

Of course, in approaching a Sentence Equivalence, we do want to analyze the sentence the same way we would with a Text Completion—read for a textual clue that tells you what type of word MUST go in the blank. Then look for a matching pair.

*Strategy Tip: If you're sure that a word in the choices does NOT have a partner, cross it out! For instance, if A and C are partners, and E and F are partners, and you're sure B and D are not each other's partners, cross out B and D completely. They cannot be the answer together, nor can either one be part of the answer.*

The sentence for the answer choice above could read,

Though the dinner guests were quite \_\_\_\_\_, the hostess did her best to keep the conversation active and engaging.

Thus, B and E are the best choices. Let's try an example.

While athletes usually expect to achieve their greatest feats in their teens or twenties, opera singers don't reach the \_\_\_\_\_ of their vocal powers until middle age.

- A harmony
- B zenith
- C acme
- D terminus
- E nadir
- F cessation

**Solution:**

Those with strong vocabularies might go straight to the choices to make pairs. ZENITH and ACME are synonyms, meaning “high point, peak.” TERMINUS and CESSATION are synonyms, meaning “end.” NADIR is a low point and HARMONY is present here as a trap answer reminding us of opera singers. *Cross off A and E, since they do not have partners.* Then, go back to the sentence, knowing that your only options are a pair meaning “peak” and a pair meaning “end.”

The answer is {B, C}.

**Math: Quantitative Comparison**

This format is a holdover from the old exam. Here’s a quick example:

**Quantity A** $x$ **Quantity B** $x^2$ 

- (A) Quantity A is greater.
- (B) Quantity B is greater.
- (C) The two quantities are equal.
- (D) The relationship cannot be determined from the information given.

**Solution:** If  $x = 0$ , the quantities are equal. If  $x = 2$ , quantity B is greater. Thus, we don’t have enough information.

The answer is D.

Let’s look at the new math question formats.

**Math: Select One or More Answer Choices**

According to the *Official Guide to the GRE Revised General Test*, the official directions for “Select One or More Answer Choices” read as follows:

**Directions:** Select one or more answer choices according to the specific question directions.

If the question does not specify how many answer choices to select, select all that apply.

The correct answer may be just one of the choices or as many as all of the choices, depending on the question.

No credit is given unless you select all of the correct choices and no others.

If the question specifies how many answer choices to select, select exactly that number of choices.

Note that there is no “partial credit.” If three of six choices are correct and you select two of the three, no credit is given. It will also be important to read the directions carefully.

That said, many of these questions look *very* similar to those on the “old” GRE. For instance, here is a question that could have appeared on the GRE in the past:

If  $ab = |a| \times |b|$ , which of the following *must* be true?

- I.  $a = b$
  - II.  $a > 0$  and  $b > 0$
  - III.  $ab > 0$
- A. II only
  - B. III only
  - C. I and III only
  - D. II and III only
  - E. I, II, and III

**Solution:** If  $ab = |a| \times |b|$ , then we know  $ab$  is positive, since the right side of the equation must be positive. If  $ab$  is positive, however, that doesn't necessarily mean that  $a$  and  $b$  are each positive; it simply means that they have the same sign.

- I. It is not true that  $a$  must equal  $b$ . For instance,  $a$  could be 2 and  $b$  could be 3.
- II. It is not true that  $a$  and  $b$  must each be positive. For instance,  $a$  could be  $-3$  and  $b$  could be  $-4$ .
- III. True. Since  $|a| \times |b|$  must be positive,  $ab$  must be positive as well.

The answer is B (III only).

Note that, if you determined that statement I was false, you could eliminate choices C and E before considering the remaining statements. Then, if you were confident that II was also false, you could safely pick answer choice B, III only, without even trying statement III, since “None of the above” isn't an option. That is, because of the multiple choice answers, it is sometimes not necessary to consider each statement individually. This is the aspect of such problems that will change on the new exam.

Here is the same problem, in the new format.

If  $ab = |a| \times |b|$ , which of the following *must* be true?

Indicate all such statements.

- A  $a = b$
- B  $a > 0$  and  $b > 0$
- C  $ab > 0$

*Strategy Tip:* Make sure to fully “process” the statement in the question (simplify it or list the possible scenarios) before considering the answer choices. This will save you time in the long run!

Here, we would simply select choice C. The only thing that has changed is that we can't do process of elimination; we must always consider each statement individually. On the upside, the problem has become much more straightforward and compact (not every real-life problem has exactly five possible solutions; why should those on the GRE?).

**Math: Numeric Entry**

This question type requires the test taker to key a numeric answer into a box on the screen. You are not able to “work backwards” from answer choices, and in many cases it will be difficult to make a guess. However, the principles being tested are the same as on the old GRE.

Here is a sample question:

If  $x*y = 2xy - (x - y)$ , what is the value of  $3*4$ ?

**Solution:**

We are given a function involving two variables,  $x$  and  $y$ , and asked to substitute 3 for  $x$  and 4 for  $y$ :

$$\begin{aligned}x*y &= 2xy - (x - y) \\3*4 &= 2(3)(4) - (3 - 4) \\3*4 &= 24 - (-1) \\3*4 &= 25\end{aligned}$$

The answer is 25.

Thus, you would type 25 into the box.

Okay. You've now got a good start on understanding the structure and question formats of the new GRE. Now it's time to begin fine-tuning your skills.

g

**Chapter 2**  
*of*

ALGEBRA

EQUATIONS

## In This Chapter . . .

---

# S

- The Order of Operations (PEMDAS)
- Solving for a Variable with One Equation
- Solving for Variables with Two Equations
- Subtraction of Expressions
- Fraction Bars as Grouping Symbols

## EQUATIONS: SOLVING FOR VARIABLES

The GRE will expect you to be proficient at manipulating and solving algebraic equations. If you haven't faced equations since you were last in school, this can be intimidating. In this chapter, our objective is to help you become comfortable setting up and solving equations. We'll start with some basic equations (we'll even leave out the variables at first), and then work our way up to some pretty tricky problems. Let's dive in.

### The Order of Operations (PEMDAS)

$$3 + 4(5 - 1) - 3^2 \times 2 = ?$$

Before we start dealing with variables, let's spend a moment looking at expressions that are made up of only numbers, such as the example above. The GRE probably won't ask you to compute something like this directly, but learning to use order of operations on numerical expressions will help you manipulate algebraic expressions and equations. So, we have a string of numbers, with mathematical symbols in between them. Which part of the expression should you focus on first?

Intuitively, most of us think of going in the direction we read, from left to right. When we read a book, moving left to right is a wise move (unless you're reading a language such as Chinese or Hebrew). However, when we perform basic arithmetic, there is an order that is of greater importance: **the order of operations**.

The order in which you perform the mathematical functions should primarily be determined by the functions themselves. In the correct order, the six operations are **P**arentheses, **E**xponents, **M**ultiplication/**D**ivision, and **A**ddition/**S**ubtraction (or **PEMDAS**).

Before we solve a problem that requires PEMDAS, here's a quick review of the basic operations.

**Parentheses** can be written as  $()$  or  $[\ ]$  or even  $\{ \}$ .

**Exponents** are  $5^2$  ← these numbers.  $5^2$  ("five squared") can be expressed as  $5 \times 5$ . In other words, it is 5 times itself 2 times.

Likewise,  $4^3$  ("four cubed," or "four to the third power") can be expressed as  $4 \times 4 \times 4$  (4 times itself 3 times).

**Roots** are very closely related to exponents.  $\sqrt[3]{64}$  is the third root of 64 (commonly called the cube root).  $\sqrt[3]{64}$  is basically asking the question "What multiplied by itself 3 times equals 64?"  $4 \times 4 \times 4 = 64$ , so  $\sqrt[3]{64} = 4$ . The plain old square root  $\sqrt{9}$  can be thought of as  $\sqrt[2]{9}$ . "What times itself equals 9?"  $3 \times 3 = 9$ , so  $\sqrt{9} = 3$ .

Exponents and roots can also undo each other.  $\sqrt{5^2} = 5$  and  $(\sqrt[3]{7^3}) = 7$ .

**Multiplication and Division** can also undo each other.  $2 \times 3 \div 3 = 2$  and  $10 \div 5 \times 5 = 10$ .

Multiplication can be expressed with parentheses:  $(5)(4) = 5 \times 4 = 20$ . Division can be expressed with a division sign ( $\div$ ), a slash ( $/$ ) or a fraction bar ( $\frac{\quad}{\quad}$ ):  $20 \div 5 = 20/5 = \frac{20}{5} = 4$ . Also remember that multiplying or dividing by a negative number changes the sign:

$$4 \times (-2) = -8 \qquad -8 \div (-2) = 4$$

**Addition and Subtraction** can also undo each other.  $8 + 7 - 7 = 8$  and  $15 - 6 + 6 = 15$ .



**PEMDAS** is a useful acronym you can use to remember the order in which operations should be performed. Some people find it useful to write PEMDAS like this:

$$\begin{array}{c} PE^M /_D /_s \\ \longrightarrow \end{array}$$

For Multiplication/Division and Addition/Subtraction, perform whichever comes first from left-to-right. The reason that Multiplication and Division are at the same level of importance is that any Multiplication can be expressed as Division, and vice-versa.  $7 \div 2$  is equivalent to  $7 \times 1/2$ . In a sense, Multiplication and Division are two sides of the same coin.

Addition and Subtraction have this same relationship.  $3 - 4$  is equivalent to  $3 + (-4)$ . The correct order of steps to simplify our sample expression is as follows:

	$3 + 4(5 - 1) - 3^2 \times 2$
<b>Parentheses</b>	$3 + 4(4) - 3^2 \times 2$
<b>Exponents</b>	$3 + 4(4) - 9 \times 2$
<b>Multiplication or Division (left-to-right)</b>	$3 + 16 - 18$
<b>Addition or Subtraction (left-to-right)</b>	$3 + 16 - 18 = 19 - 18 = 1$

Remember: If you have two operations of equal importance, you should do them in left-to-right order:  $3 - 2 + 3 = 1 + 3 = 4$ . The only instance in which you would override this order is when the operations are in parentheses:  $3 - (2 + 3) = 3 - (5) = -2$ .

Let's do two problems together. Try it first on your own, then we'll go through it together:

P  $5 - 3 \times 4^3 \div (7 - 1)$

E

M/D

A/S

Your work should have looked like this:

$$\begin{array}{l}
 5 - 3 \times 4^3 + (7 - 1) \\
 \underline{5 - 3 \times 4^3 + 6} \quad \longrightarrow \quad 4^3 = 4 \times 4 \times 4 = 64 \rightarrow \begin{array}{r} 2 \\ 16 \\ \times 4 \\ \hline 64 \end{array} \\
 \underline{5 - 3 \times 64 + 6} \\
 \underline{5 - 192 + 6} \\
 \underline{5 - 32} \\
 -27
 \end{array}$$
  

$$\begin{array}{r}
 1 \\
 64 \\
 \times 3 \\
 \hline
 192
 \end{array}$$
  

$$\begin{array}{r}
 32 \\
 6 \overline{)192} \\
 \underline{-18} \\
 12 \\
 \underline{-12} \\
 0
 \end{array}$$
  

Let's try one more:

$$32 + 2^4 \times (5 - 3^2)$$

P

E

M/D

A/S

Here's the work you should have done:

$$32 \div 2^4 \times (5 - 3^2)$$

$$32 \div 2^4 \times (5 - 9)$$

$$32 \div 2^4 \times (-4)$$

$$32 \div 16 \times (-4)$$

$$2 \times (-4)$$

$$-8$$

### Check Your Skills

Evaluate the following expressions:

1.  $-4 + 12/3 =$

2.  $(5 - 8) \times 10 - 7 =$

3.  $-3 \times 12 \div 4 \times 8 + (4 - 6) =$

4.  $2^4 \times (8 \div 2 - 1)/(9 - 3) =$

*Answers can be found on page 41.*

## Solving for a Variable With One Equation

### Expressions vs. Equations

So far, we've been dealing only with expressions. Now we're going to be dealing with equations. The big difference between equations and expressions is that an equation consists of two expressions separated by an equals (or inequality) sign while an expression lacks an equals (or inequality) sign altogether.

Pretty much everything we will be doing with equations is related to one basic principle: we can do anything we want to one side of the equation, *as long as we also do the same thing to the other side of the equation*. Take the equation  $3 + 5 = 8$ . We want to subtract 5 from the left side of the equation, but we still want the equation to be true. All we have to do is subtract 5 from the right side as well, and we can be confident that our new equation will still be valid.

$$\begin{array}{r} 3 + 5 = 8 \\ -5 \quad -5 \\ \hline 3 \quad = 3 \end{array}$$

Note that this would also work if we had variables in our equation:

$$\begin{array}{r} x + 5 = 8 \\ -5 \quad -5 \\ \hline x \quad = 3 \end{array}$$

Next we're going to see some of the many ways we can apply this principle to solving algebra problems.

## Solving Equations

What does it mean to solve an equation? What are we really doing when we manipulate algebraic equations?

A solution to an equation is a number that, when substituted in for the value of a variable, makes the equation *true*.

Take the equation  $2x + 7 = 15$ . We are looking for the value of  $x$  that will make this equation true. What if we plugged in 3 for  $x$ ? If we replaced  $x$  with the number 3, we would get  $2(3) + 7 = 15$ . This equation can be simplified to  $6 + 7 = 15$ , which further simplifies to  $13 = 15$ . 13 definitely does NOT equal 15, so when  $x = 3$ , the equation is NOT true. So  $x = 3$  is NOT a solution to the equation.

Now, if we replaced  $x$  with the number 4, we would get  $2(4) + 7 = 15$ . This equation can be simplified to  $8 + 7 = 15$ . Simplify it further, and we get  $15 = 15$ , which is a true statement.

That means that when  $x = 4$ , the equation is true. So  $x = 4$  is a solution to the equation.

Now the question becomes, what is the best way to find these solutions? What is an efficient way to determine what value or values of a variable will make an equation true? If we had to use trial and error, or guessing, the process could take a very long time. The following sections will talk about the ways in which we can efficiently and accurately manipulate equations so that solutions become easier to find.

## Isolating a Variable

We know that we can make a change to an equation as long as we make the same change to both sides. Now let's look at the various changes we can make. We'll discuss these changes as we try to solve the following problem:

$$\text{If } 5(x - 1)^3 - 30 = 10, \text{ then } x = ?$$

To solve for a variable, we need to get it by itself on one side of the equals sign. To do that, we'll need to change the appearance of the equation, but not its value. The good news is that all of the changes we will need to make to this equation to solve for  $x$  will actually be very familiar to you—PEMDAS operations!

To get  $x$  by itself, we want to move every term that *doesn't include* the variable to the other side of the equation. The easiest thing to move at this stage is the 30, so let's start there. If 30 is being subtracted on the left side of the equation, and we want to move it to the other side, then we need to do the opposite operation in order to cancel it out. So we're going to **add** 30 to both sides, like this:

$$\begin{array}{r} 5(x - 1)^3 - 30 = 10 \\ \quad \quad \quad +30 + 30 \\ \hline 5(x - 1)^3 \quad \quad = 40 \end{array}$$

Now we've only got one term on the left side of the equation.  $x$  is still inside the parentheses, and the expression in the parentheses is being multiplied by 5, so the next step will be to move that 5 over to the other side of the equation. Once again, we want to perform the opposite operation, so we'll **divide** both sides of the equation by 5.

$$\frac{5(x - 1)^3}{5} = \frac{40}{5}$$

← These horizontal lines mean division.

$$(x - 1)^3 = 8$$

Now at this point we could cube  $(x - 1)$ , but that is going to involve a whole lot of multiplication. Instead, we can get rid of the exponent by performing the opposite operation. The opposite of exponents is roots. So if the left side of the equation is raised to the third power, we can undo that by taking the third root of both sides, also known as the cube root.

$$\sqrt[3]{(x-1)^3} = \sqrt[3]{8}$$

$$(x-1) = 2$$

Now that nothing else is being done to the parentheses, we can just get rid of them. The equation is:

$$x - 1 = 2$$

After that, we add 1 to both sides, and we get  $x = 3$ . This would have been hard to guess!

Now, take a look at the steps that we took in order to isolate  $x$ . Notice anything? We **added** 30, then we **divided** by 5, then we got rid of the **exponent** and then we simplified our **parentheses**. We did PEMDAS backwards! And in fact, when you're isolating a variable, it turns out that the simplest way to do so is to reverse the order of PEMDAS when deciding what order you will perform your operations. Start with addition/subtraction, then multiplication/division, then exponents, and finish with terms in parentheses.

Now that you know the best way to isolate a variable, let's go through one more example. Try it on your own first, then we'll go through it together.

$$\text{If } 4\sqrt{x-6} + 7 = 19, \text{ then } x = ?$$

A/S

M/D

E

P

Let's get started. The equation we're simplifying is  $4\sqrt{x-6} + 7 = 19$ . If there's anything to add or subtract, that will be the easiest first step. There is, so the first thing we want to do is get rid of the 7 by subtracting 7 from both sides.

$$\begin{array}{r} 4\sqrt{x-6} + 7 = 19 \\ \underline{-7 \quad -7} \\ = 12 \end{array}$$

Now we want to see if there's anything being multiplied or divided by the term containing an  $x$ . The square root that contains the  $x$  is being multiplied by 4, so our next step will be to get rid of the 4. We can do that by dividing both sides of the equation by 4.

$$\frac{4\sqrt{(x-6)}}{4} = \frac{12}{4}$$

$$\sqrt{(x-6)} = 3$$

Now that we've taken care of multiplication and division, it's time to check for exponents. And that really means we need to check for exponents and roots, because they're so intimately related. There are no exponents in the equation, but the  $x$  is inside a square root. In order to cancel out a root, we can use an exponent. Squaring a square root will cancel it out, so our next step is to square both sides.

$$\sqrt{(x-6)} = 3$$

$$\left(\sqrt{(x-6)}\right)^2 = 3^2$$

$$x-6=9$$

The final step is to add 6 to both sides, and we end up with  $x = 15$ .

### Check Your Skills

Solve for  $x$  in the following equations:

5.  $3(x+4)^3 - 5 = 19$

6.  $\frac{3x-7}{2} + 20 = 6$

7.  $\sqrt[3]{(x+5)} - 7 = -8$

*Answers can be found on page 41.*

### Equation Clean-Up Moves

We've covered the basic operations that we'll be dealing with when solving equations. But what would you do if you were asked to solve for  $x$  in the following equation?

$$\frac{5x-3(4-x)}{2x} = 10$$

Now  $x$  appears in multiple parts of the equation, and our job has become more complicated. In addition to our PEMDAS operations, we also need to be able to simplify, or clean up, our equation. Let's see the different ways we can clean up this equation. First, notice how we have an  $x$  in the denominator (the bottom of the fraction) on the left side of the equation. We're trying to find the value of  $x$ , not of some number divided by  $x$ . So our first clean-up move is to **always get variables out of denominators**. The way to do that is to multiply both sides of the equation by the *entire* denominator. Watch what happens:

$$\cancel{2x} \times \frac{5x-3(4-x)}{\cancel{2x}} = 10 \times 2x$$

If you multiply a fraction by its denominator, you can cancel out the entire denominator. Now we're left with

$$5x - 3(4 - x) = 20x$$

No more fractions! What should we do next? At some point, if we want the value of  $x$ , we're going to have to get all the terms that contain an  $x$  together. But right now, that  $x$  sitting inside the parentheses seems pretty tough to get to. To make that  $x$  more accessible, we should **simplify grouped terms within the equation**. That 3 on the outside of the parentheses wants to multiply the terms inside, so we need to **distribute** it. What that means is we're going to multiply the 3 by the terms inside, one at a time. 3 times 4 is 12, and 3 times  $-x$  is  $-3x$ , so our equation becomes

$$5x - (12 - 3x) = 20x$$

Now, if we subtract what's in the parentheses from  $5x$ , we can get rid of the parentheses altogether. Just as we multiplied the 3 by *both* terms inside the parentheses, we also have to subtract both terms.

$$5x - (12) - (-3x) = 20x$$

$$5x - 12 + 3x = 20x$$

Remember, subtracting a negative number is the same as adding a positive number; the negative signs cancel out!

Now we're very close. We're ready to make use of our final clean up move—**combine like terms**. "Like terms" are terms that can be combined into one term. For example, " $3x$ " and " $5x$ " are like terms because they can be combined into " $8x$ ." Ultimately, all the PEMDAS operations and clean up moves have one goal—to get a variable by itself so we can determine its value. At this point, we have 4 terms in the equation:  $5x$ ,  $-12$ ,  $3x$  and  $20x$ . We want to get all the terms with an  $x$  on one side of the equation, and all the terms that only contain numbers on the other side.

First, let's combine  $5x$  and  $3x$ , because they're on the same side of the equation. That gives us:

$$8x - 12 = 20x$$

Now we want to get the  $8x$  together with the  $20x$ . But which one should we move? The best move to make here is to move the  $8x$  to the right side of the equation, because that way, one side of the equation will have terms that contain only numbers ( $-12$ ) and the right side will have terms that contain variables ( $8x$  and  $20x$ ). So now it's time for our PEMDAS operations again. Let's find  $x$ .

$$\begin{array}{r} 8x - 12 = 20x \\ -8x \quad \quad -8x \\ \hline -12 = 12x \\ \frac{-12}{12} = \frac{12x}{12} \\ -1 = x \end{array}$$

Before moving on to the next topic, let's review what we've learned.

- You can do whatever you want to one side of the equation, as long as you do the same to the other side at the same time.
- To isolate a variable, you should perform the PEMDAS operations in **reverse order**:
  1. Addition/Subtraction
  2. Multiplication/Division
  3. Exponents/Roots
  4. Parentheses
- To clean up an equation:
  - a) Get variables out of denominators by multiplying both sides by that entire denominator
  - b) Simplify grouped terms by multiplying or distributing
  - c) Combine similar or like terms

### Check Your Skills

Solve for  $x$  in the following equations.

$$8. \frac{11+3(x+4)}{x-3} = 7$$

$$9. \frac{-6-5(3-x)}{2-x} = 6$$

$$10. \frac{2x+6(9-2x)}{x-4} = -3$$

*Answers can be found on page 42.*

## Solving for Variables with Two Equations

Some GRE problems, including word problems, give you two equations, each of which has two variables. To solve such problems, you'll need to solve for one or each of those variables. At first glance, this problem may seem quite daunting:

$$\text{If } 3x + y = 10 \text{ and } y = x - 2, \text{ what is the value of } y?$$

Maybe you've gotten pretty good at solving for one variable, but now you face two variables and two equations!

You might be tempted to test numbers, and indeed you could actually solve the above problem that way. Could you do so in under two minutes? Maybe not. Fortunately, there is a much faster way.

### Substitution

One method for combining equations is called substitution. In substitution, we *insert the expression for one variable in one equation into that variable in the other equation*. The goal is to end up with one equation with one variable, because once you get a problem to that point, you know you can solve it!



There are four basic steps to substitution, which we'll demonstrate with the question from above.

**Step One** is to isolate one of the variables in one of the equations. For this example,  $y$  is already isolated in the second equation:  $y = x - 2$ .

For **Step Two**, it is important to understand that the left and right sides of the equation are equivalent. This may seem obvious, but it has some interesting implications. If  $y$  equals  $x - 2$ , then that means we could replace the variable  $y$  with the expression  $(x - 2)$  and the equation would have the same value. And in fact, that's exactly what we're going to do. Step Two will be to go to the first equation, and substitute (hence the name) the variable  $y$  with its equivalent,  $(x - 2)$ . So:

$$3x + y = 10 \rightarrow 3x + (x - 2) = 10$$

Now for **Step Three**, we have one equation and one variable, so the next step is to solve for  $x$ .

$$3x + x - 2 = 10$$

$$4x = 12$$

$$x = 3$$

Now that we have a value for  $x$ , **Step Four** is to use that value to solve for our second variable,  $y$ .

$$y = x - 2 \rightarrow y = (3) - 2 = 1$$

So the answer to our question is  $y = 1$ . **It should be noted that Step Four will only be necessary if the variable you solve for in Step Three is not the variable the question asks for.** The question asked for  $y$ , but we found  $x$ , so Step Four was needed to answer the question.

Now that you've gotten the hang of substitution, let's try a new problem:

If  $2x + 4y = 14$  and  $x - y = -8$ , what is the value of  $x$ ?

As we learned, the first step is to isolate our variable. Because the question asks for  $x$ , we should manipulate the second equation to isolate  $y$ . Taking this approach will make Step Four unnecessary and save us time.

$$x - y = -8$$

$$x = -8 + y$$

$$x + 8 = y$$

Then for Step Two we can substitute for  $y$  in the first equation.

$$2x + 4y = 14$$

$$2x + 4(x + 8) = 14$$

Now for Step Three we isolate  $x$ .

$$2x + 4x + 32 = 14$$

$$6x = -18$$

$$x = -3$$

So the answer to our question is  $x = -3$ .

**Check Your Skills**

Solve for  $x$  and  $y$  in the following equations.

11.  $x = 10$

$x + 2y = 26$

12.  $x + 4y = 10$

$y - x = -5$

13.  $6y + 15 = 3x$

$x + y = 14$

*Answers can be found on pages 42–43.*

**Subtraction of Expressions**

One of the most common errors involving order of operations occurs when an expression with multiple terms is subtracted. The subtraction must occur across EVERY term within the expression. Each term in the subtracted part must have its sign reversed. For example:

$$x - (y - z) = x - y + z \quad (\text{note that the signs of both } y \text{ and } -z \text{ have been reversed})$$

$$x - (y + z) = x - y - z \quad (\text{note that the signs of both } y \text{ and } z \text{ have been reversed})$$

$$x - 2(y - 3z) = x - 2y + 6z \quad (\text{note that the signs of both } y \text{ and } -3z \text{ have been reversed})$$

What is  $5x - [y - (3x - 4y)]$ ?

Both expressions in parentheses must be subtracted, so the signs of each term must be reversed for EACH subtraction. Note that the square brackets are just fancy parentheses, used so that we avoid having parentheses right next to each other. Work from the innermost parentheses outward.

$$5x - [y - (3x - 4y)] =$$

$$5x - [y - 3x + 4y] =$$

$$5x - y + 3x - 4y = 8x - 5y$$

**Check Your Skills**

14. Simplify:  $3a - [2a - (3b - a)]$

*Answer can be found on page 43.*

**Fraction Bars as Grouping Symbols**

Even though fraction bars do not fit into the PEMDAS hierarchy, they do take precedence. In any expression with a fraction bar, you should **pretend that there are parentheses around the numerator and denominator of the fraction**. This may be obvious as long as the fraction bar remains in the expression, but it is easy to forget if you eliminate the fraction bar or add or subtract fractions, so put parentheses in to remind yourself.

$$\text{Simplify: } \frac{x-1}{2} - \frac{2x-1}{3} \rightarrow \text{Write on your paper as: } \frac{(x-1)}{2} - \frac{(2x-1)}{3}$$

The common denominator for the two fractions is 6, so multiply the numerator and denominator of the first fraction by 3, and those of the second fraction by 2:

$$\frac{(x-1)\left(\frac{3}{3}\right) - \frac{(2x-1)\left(\frac{2}{2}\right)}{3} = \frac{(3x-3)}{6} - \frac{(4x-2)}{6}$$

Once we put all numerators over the common denominator, the parentheses remind us to reverse the signs of both terms in the second numerator:

$$\frac{(3x-3) - (4x-2)}{6} = \frac{3x-3-4x+2}{6} = \frac{-x-1}{6} = -\frac{x+1}{6}$$

### Check Your Skills

15. Simplify:  $\frac{a+4}{4} - \frac{2a-2}{3}$

*Answer can be found on page 43.*

## Check Your Skills Answer Key:

1. **0:**  $-4 + 12/3 =$   
 $-4 + 4 = 0$   
 Divide first  
 Then add the two numbers
2. **-37:**  $(5 - 8) \times 10 - 7 =$   
 $(-3) \times 10 - 7 =$   
 $-30 - 7 =$   
 $-30 - 7 = -37$   
 First, combine what is inside the parentheses  
 Then multiply  $-3$  and  $10$   
 Subtract the two numbers
3. **-74:**  $-3 \times 12 \div 4 \times 8 + (4 - 6)$   
 $-3 \times 12 \div 4 \times 8 + (-2)$   
 $-36 \div 4 \times 8 + (-2)$   
 $-9 \times 8 - 2$   
 $-72 + (-2) = -74$   
 First, combine what's in the parentheses  
 Multiply  $-3$  and  $12$   
 Divide  $-36$  by  $4$   
 Multiply  $-9$  by  $8$  and subtract  $2$
4. **8:**  $2^4 \times (8 \div 2 - 1) / (9 - 3) =$   
 $2^4 \times (4 - 1) / (6) =$   
 $16 \times (3) / (6) =$   
 $48 / 6 =$   
 $48 / 6 = 8$   
 $8/2 = 4$  and  $9 - 3 = 6$   
 $4 - 1 = 3$  and  $2^4 = 16$   
 Multiply  $16$  by  $3$   
 Divide  $48$  by  $6$
5.  **$x = -2$ :**  $3(x + 4)^3 - 5 = 19$   
 $3(x + 4)^3 = 24$   
 $(x + 4)^3 = 8$   
 $(x + 4) = 2$   
 $x = -2$   
 Add  $5$  to both sides  
 Divide both sides by  $3$   
 Take the cube root of both sides  
 Remove the parentheses, subtract  $4$  from both sides
6.  **$x = -7$ :**  $\frac{3x - 7}{2} + 20 = 6$   
 $\frac{3x - 7}{2} = -14$   
 $3x - 7 = -28$   
 $3x = -21$   
 $x = -7$   
 Subtract  $20$  from both sides  
 Multiply both sides by  $2$   
 Add  $7$  to both sides  
 Divide both sides by  $3$
7.  **$x = -6$ :**  $\sqrt[3]{(x + 5)} - 7 = -8$   
 $\sqrt[3]{(x + 5)} = -1$   
 $x + 5 = -1$   
 $x = -6$   
 Add  $7$  to both sides  
 Cube both sides, remove parentheses  
 Subtract  $5$  from both sides

$$8. x = 11: \frac{11 - 3(x + 4)}{x - 3} = 7$$

$$11 + 3(x + 4) = 7(x - 3)$$

$$11 + 3x + 12 = 7x - 21$$

$$23 + 3x = 7x - 21$$

$$23 = 4x - 21$$

$$44 = 4x$$

$$11 = x$$

Multiply both sides by the denominator  $(x - 3)$

Simplify grouped terms by distributing

Combine like terms (11 and 12)

Subtract  $3x$  from both sides

Add 21 to both sides

Divide both sides by 4

$$9. x = 3: \frac{-6 - 5(3 - x)}{2 - x} = 6$$

$$-6 - 5(3 - x) = 6(2 - x)$$

$$-6 - 15 + 5x = 12 - 6x$$

$$-21 + 5x = 12 - 6x$$

$$-21 + 11x = 12$$

$$11x = 33$$

$$x = 3$$

Multiply both sides by the denominator  $(2 - x)$

Simplify grouped terms by distributing

Combine like terms ( $-6$  and  $-15$ )

Add  $6x$  to both sides

Add 21 to both sides

Divide both sides by 11

$$10. x = 6: \frac{2x + 6(9 - 2x)}{x - 4} = -3$$

$$2x + 6(9 - 2x) = -3(x - 4)$$

$$2x + 54 - 12x = -3x + 12$$

$$-10x + 54 = -3x + 12$$

$$54 = 7x + 12$$

$$42 = 7x$$

$$6 = x$$

Multiply by the denominator  $(x - 4)$

Simplify grouped terms by distributing

Combine like terms ( $2x$  and  $-12x$ )

Add  $10x$  to both sides

Subtract 12 from both sides

Divide both sides by 7

$$11. x = 10, y = 8: \quad x = 10$$

$$x + 2y = 26$$

$$(10) + 2y = 26$$

$$2y = 16$$

$$y = 8$$

Substitute 10 for  $x$  in the second equation

Subtract 10 from both sides

Divide both sides by 2

$$12. x = 6, y = 1: \quad x + 4y = 10$$

$$y - x = -5$$

$$y = x - 5$$

$$x + 4(x - 5) = 10$$

$$x + 4x - 20 = 10$$

$$5x - 20 = 10$$

$$5x = 30$$

$$x = 6$$

$$y - (6) = -5$$

$$y = 1$$

Isolate  $y$  in the second equation

Substitute  $(x - 5)$  for  $y$  in the first equation

Simplify grouped terms within the equation

Combine like terms ( $x$  and  $4x$ )

Add 20 to both sides

Divide both sides by 5

Substitute 6 for  $x$  in the second equation to solve for  $y$

Add 6 to both sides

13.  $x = 11, y = 3:$        $6y + 15 = 3x$   
     $x + y = 14$

$$\begin{aligned} 2y + 5 &= x \\ (2y + 5) + y &= 14 \\ 3y + 5 &= 14 \\ 3y &= 9 \\ y &= 3 \\ x + (3) &= 14 \\ x &= 11 \end{aligned}$$

Divide the first equation by 3  
 Substitute  $(2y + 5)$  for  $x$  in the second equation  
 Combine like terms ( $2y$  and  $y$ )  
 Subtract 5 from both sides  
 Divide both sides by 3  
 Substitute  $(3)$  for  $y$  in the second equation to solve for  $x$

14. **3b:**  $3a - [2a - (3b - a)]$   
 $= 3a - [2a - 3b + a]$   
 $= 3a - [3a - 3b]$   
 $= 3a - 3a + 3b$   
 $= 3b$

15.  $\frac{20 - 5a}{12} \div \frac{a + 4}{4} - \frac{2a - 2}{3}$   
 $= \frac{3}{3} \times \frac{(a + 4)}{4} - \frac{4}{4} \times \frac{(2a - 2)}{3}$   
 $= \frac{3(a + 4)}{12} - \frac{4(2a - 2)}{12}$   
 $= \frac{3(a + 4) - 4(2a - 2)}{12}$   
 $= \frac{3a + 12 - 8a + 8}{12}$   
 $= \frac{20 - 5a}{12}$

## Problem Set

- Evaluate  $-3x^2$ ,  $-3x^3$ ,  $3x^2$ ,  $(-3x)^2$ , and  $(-3x)^3$  if  $x = 2$ , and also if  $x = -2$ .
- Evaluate  $(4 + 12 \div 3 - 18) - [-11 - (-4)]$ .
- Which of the parentheses in the following expressions are unnecessary and could thus be removed without any change in the value of the expression?

(a)  $-(5^2) - (12 - 7)$

(b)  $(x + y) - (w + z) - (a \times b)$

4. Evaluate  $\left[ \frac{4+8}{2-(-6)} \right] - [4+8+2-(-6)]$ .

5. Simplify:  $x - (3 - x)$ .

6. Simplify:  $(4 - y) - 2(2y - 3)$ .

7. Solve for  $x$ :  $2(2 - 3x) - (4 + x) = 7$ .

8. Solve for  $z$ :  $\frac{4z-7}{3-2z} = -5$ .

9.

**Quantity A**

$$3 \times (5 + 6) \div -1$$

**Quantity B**

$$3 \times 5 + 6 \div -1$$

10.

$$(x - 4)^3 + 11 = -16$$

**Quantity A**

$x$

**Quantity B**

$-4$

11.

$$2x + y = 10$$

$$3x - 2y = 1$$

**Quantity A**

$x$

**Quantity B**

$y$

1. If  $x = 2$ :

$$\begin{aligned} -3x^2 &= -3(4) = -12 \\ -3x^3 &= -3(8) = -24 \\ 3x^2 &= 3(4) = 12 \\ (-3x)^2 &= (-6)^2 = 36 \\ (-3x)^3 &= (-6)^3 = -216 \end{aligned}$$

If  $x = -2$ :

$$\begin{aligned} -3x^2 &= -3(4) = -12 \\ -3x^3 &= -3(-8) = 24 \\ 3x^2 &= 3(4) = 12 \\ (-3x)^2 &= 6^2 = 36 \\ (-3x)^3 &= 6^3 = 216 \end{aligned}$$

Remember that exponents are evaluated *before* multiplication! Watch not only the order of operations, but also the signs in these problems.

2.  $-3: (4 + 12 \div 3 - 18) - [-11 - (-4)] =$

$$\begin{aligned} (4 + 4 - 18) - (-11 + 4) &= \\ (-10) - (-7) &= \\ -10 + 7 &= -3 \end{aligned}$$

3. (a): The parentheses around  $5^2$  are unnecessary, because this exponent is performed before the negation (which counts as multiplying by  $-1$ ) and before the subtraction. The other parentheses are necessary, because they cause the right-hand subtraction to be performed before the left-hand subtraction. Without them, the two subtractions would be performed from left to right.

(b): The first and last pairs of parentheses are unnecessary. The addition is performed before the neighboring subtraction by default, because addition and subtraction are performed from left to right. The multiplication is the first operation to be performed, so the right-hand parentheses are completely unnecessary. The middle parentheses are necessary to ensure that the addition is performed before the subtraction that comes to the left of it.

4.  $-\frac{25}{2} : \left[ \frac{4+8}{2-(-6)} \right] - [4+8 \div 2 - (-6)] =$

$$\left( \frac{4+8}{2+4} \right) - (4+8 \div 2 + 6) = \quad \text{subtraction of negative = addition}$$

$$\left( \frac{12}{8} \right) - (4+4+6) = \quad \text{fraction bar acts as a grouping symbol}$$

$$\frac{3}{2} - 14 = \quad \text{arithmetic}$$

$$\frac{3}{2} - \frac{28}{2} = -\frac{25}{2} \quad \text{arithmetic}$$

5.  $2x - 3$ : Do not forget to reverse the signs of every term in a subtracted expression.

$$x - (3 - x) = x - 3 + x = 2x - 3$$



6. **-5y + 10 (or 10 - 5y):** Do not forget to reverse the signs of every term in a subtracted expression.

$$(4 - y) - 2(2y - 3) = 4 - y - 4y + 6 = -5y + 10 \text{ (or } 10 - 5y)$$

7. **-1:**  $2(2 - 3x) - (4 + x) = 7$

$$4 - 6x - 4 - x = 7$$

$$-7x = 7$$

$$x = -1$$

8. **4/3:**

$$\frac{4z - 7}{3 - 2z} = -5$$

$$4z - 7 = -5(3 - 2z)$$

$$4z - 7 = -15 + 10z$$

$$8 = 6z$$

$$z = 8/6 = 4/3$$

9. **B:** Evaluate Quantity A first:

$$3 \times (5 + 6) \div -1$$

$$3 \times (11) \div -1$$

$$33 \div -1$$

$$-33$$

Simplify the parentheses

Multiply and divide in order from left to right

Now evaluate Quantity B:

$$3 \times 5 + 6 \div -1$$

$$15 + -6$$

$$9$$

Multiply and divide in order from left to right

Add

Quantity A

-33

Quantity B

9

**Quantity B is greater.**

10. **A:** Simplify the given equation to solve for  $x$ .

$$(x - 4)^3 + 11 = -16$$

$$(x - 4)^3 = -27$$

$$x - 4 = -3$$

$$x = 1$$

$$(x - 4)^3 + 11 = -16$$

Quantity A

$x = 1$

Quantity B

-4

**Quantity A is greater.**

11. **B:** Use substitution to solve for the values of  $x$  and  $y$ .

$$2x + y = 10 \rightarrow y = 10 - 2x$$

$$3x - 2y = 1 \rightarrow 3x - 2(10 - 2x) = 1$$

$$3x - 20 + 4x = 1$$

$$7x = 21$$

$$x = 3$$

$$2x + y = 10 \rightarrow 2(3) + y = 10$$

$$6 + y = 10$$

$$y = 4$$

Isolate  $y$  in the first equation

Substitute  $(10 - 2x)$  for  $y$  in the second equation

Distribute

Substitute 3 for  $x$  in the first equation

Quantity A

$$x = 3$$

Quantity B

$$y = 4$$

**Quantity B is greater.**

g

**Chapter 3**

*of*

ALGEBRA

QUADRATIC  
EQUATIONS

## In This Chapter . . .

---

# S

- Identifying Quadratic Equations
- Distributing
- Factoring
- How Do We Apply This To Quadratics?
- Factoring Quadratic Equations
- Solving Quadratic Equations
- One Solution Quadratics
- Zero in the Denominator: Undefined
- The Three Special Products

## Identifying Quadratic Equations

We'll begin this section with a question:

$$\text{If } x^2 = 4, \text{ what is } x?$$

We know what to do here. Simply take the square root of both sides.

$$\sqrt{x^2} = \sqrt{4}$$

$$x = 2$$

So  $x = 2$ . The question seems to be answered. But, what if  $x$  were equal to  $-2$ ? What would be the result? Let's plug  $-2$  in for  $x$ .

$$(-2)^2 = 4 \longrightarrow 4 = 4$$

If plugging  $-2$  in for  $x$  yields a true statement, then  $-2$  must be a solution to the equation. But, from our initial work, we know that  $2$  is a solution to the equation. So which one is correct?

As it turns out, they both are. An interesting thing happens when you start raising variables to exponents. The number of possible solutions increases. When a variable is squared, as in our example above, it becomes possible that there will be 2 solutions to the equation.

What this means is that whenever you see an equation with a squared variable, you need to

1. Recognize that the equation may have 2 solutions
2. Know how to find both solutions

A quadratic equation is any equation for which the highest power on a variable is the second power (e.g.  $x^2$ ).

For an equation like  $x^2 = 25$  or  $x^2 = 9$ , finding both solutions shouldn't be too challenging. Take a minute to find both solutions for each equation.

You should have found that  $x$  equals either  $5$  or  $-5$  in the first equation, and  $3$  or  $-3$  in the second equation. But what if you are asked to solve for  $x$  in the following equation?

$$x^2 + 3x - 10 = 0$$

Unfortunately, we don't yet have the ability to deal with equations like this, which is why the next part of this chapter will deal with some more important tools for manipulating and solving **quadratic equations: distributing & factoring**.

## Distributing

We first came across distributing when we were learning how to clean up equations and isolate a variable. Essentially, distributing is applying multiplication across a sum.

To review, if we are presented with the expression  $3(x + 2)$ , and we want to simplify it, we have to distribute the  $3$  so that it is multiplied by both the  $x$  and the  $2$ .

$$3(x + 2) \rightarrow (3 \times x) + (3 \times 2) \rightarrow 3x + 6$$

But what if the first part of the multiplication is more complicated? Suppose you need to simplify  $(a + b)(x + y)$ ?

Simplifying this expression is really an extension of the principle of distribution—every term in the first part of the expression must multiply every term in the second part of the expression. In order to do so correctly every time, we can use a handy acronym to remember the steps necessary: FOIL. The letters stand for **F**irst, **O**utside, **I**nside, **L**ast.

In this case, it looks like this:

$$\begin{array}{ll} (a + b)(x + y) & \text{F – multiply the first term in each of the parentheses: } a \times x = ax \\ (a + b)(x + y) & \text{O – multiply the outer term in each: } a \times y = ay \\ (a + b)(x + y) & \text{I – multiply the inner term in each: } b \times x = bx \\ (a + b)(x + y) & \text{L – multiply the last term in each: } b \times y = by \end{array}$$

So we have  $(a + b)(x + y) = ax + ay + bx + by$ .

Let's verify this system with numbers. Take the expression  $(3 + 4)(10 + 20)$ . This is no different than multiplying  $(7)(30)$ , which gives us 210. Let's see what happens when we FOIL the numbers.

$$\begin{array}{ll} (3 + 4)(10 + 20) & \text{F – multiply the first term in each of the parentheses: } 3 \times 10 = 30 \\ (3 + 4)(10 + 20) & \text{O – multiply the outer term in each: } 3 \times 20 = 60 \\ (3 + 4)(10 + 20) & \text{I – multiply the inner term in each: } 4 \times 10 = 40 \\ (3 + 4)(10 + 20) & \text{L – multiply the last term in each: } 4 \times 20 = 80 \end{array}$$

Finally, we sum the four products!  $30 + 60 + 40 + 80 = 210$ .

Now that we have the basics down, let's go through a more GRE-like situation. Take the expression  $(x + 2)(x + 3)$ . One again, we begin by FOILing it.

$$\begin{array}{ll} (x + 2)(x + 3) & \text{F – multiply the first term in each of the parentheses: } x \times x = x^2 \\ (x + 2)(x + 3) & \text{O – multiply the outer term in each: } x \times 3 = 3x \\ (x + 2)(x + 3) & \text{I – multiply the inner term in each: } 2 \times x = 2x \\ (x + 2)(x + 3) & \text{L – multiply the last term in each: } 2 \times 3 = 6 \end{array}$$

The expression becomes  $x^2 + 3x + 2x + 6$ . We combine like terms, and we are left with  $x^2 + 5x + 6$ . In the next section we'll discuss the connection between distributing, factoring, and solving quadratic equations. But for the moment, let's practice foiling expressions.

### Check Your Skills

FOIL the following expressions:

- $(x + 4)(x + 9)$
- $(y + 3)(y - 6)$
- $(x + 7)(3 + x)$

*Answers can be found on page 67.*

## Factoring

What is factoring? *Factoring is the process of reversing distributing terms.*

For example, when we multiply  $y$  and  $(5 - y)$ , we get  $5y - y^2$ . Reversing this, if you're given  $5y - y^2$ , you can "factor out" a  $y$  to transform the expression into  $y(5 - y)$ . Another way of thinking about factoring is that you're *pulling out* a common term and rewriting the expression as a *product*.

You can factor out many different things on the GRE: variables, variables with exponents, numbers, and expressions with more than one term such as  $(y - 2)$  or  $(x + w)$ . Here are some examples:

$$\begin{aligned} t^2 + t & \quad \text{Factor out a } t. \text{ Notice that a } 1 \text{ remains behind when you factor a } t \text{ out of a } t. \\ = t(t + 1) \end{aligned}$$

$$\begin{aligned} 5k^3 - 15k^2 & \quad \text{Factor out a } 5k^2. \\ = 5k^2(k - 3) \end{aligned}$$

$$\begin{aligned} 21j + 35k & \quad \text{Factor out a } 7\text{—since the variables are different, you can't factor out any variables.} \\ = 7(3j + 5k) \end{aligned}$$

If you ever doubt whether you've factored correctly, just distribute back. For instance,  $t(t + 1) = t \times t + t \times 1 = t^2 + t$ , so  $t(t + 1)$  is the correct factored form of  $t^2 + t$ .

You should factor expressions for several reasons. One common reason is to simplify an expression (the GRE complicates equations that are actually quite simple). The other reason (which we will discuss in more detail shortly) is to find possible values for a variable or combination of variables.

### Check Your Skills

Factor the following expressions:

4.  $4 + 8t$

5.  $5x + 25y$

6.  $2x^2 + 16x^3$

*Answers can be found on page 67.*

## How Do We Apply This to Quadratics?

If you were told that  $7x = 0$ , you would know that  $x$  must be 0. This is because the only way to make the product of two or more numbers equal 0 is to have one of those numbers equal 0. 7 does not equal 0, which means that  $x$  must be 0.

Now, what if we were told that  $kj = 0$ ? Well, now we have two possibilities. If  $k = 0$ , then  $0(j) = 0$ , which is true, so  $k = 0$  is a solution to the equation  $kj = 0$ . Likewise, if  $j = 0$ , then  $k(0) = 0$ , which is also true, so  $j = 0$  is also a solution to  $kj = 0$ .

Either of these scenarios make the equation true, and in fact are the only scenarios that make the product  $kj = 0$ . (If this is not clear, try plugging in non-zero numbers for both  $k$  and  $j$ , and see what happens.)

So this is why we want to rewrite quadratic equations such as  $x^2 + 3x - 10 = 0$  in factored form:  $(x + 5)(x - 2) = 0$ . The left side of the factored equation is a *product*, so it's really the same thing as  $jk = 0$ . Now we know that either  $x + 5$  is 0, or  $x - 2$  is 0. This means either  $x = -5$  or  $x = 2$ . Once you've factored a quadratic equation, it's straightfor-

ward to find the solutions.

**Check Your Skills**

List all possible solutions to the following equations.

7.  $(x - 2)(x - 1) = 0$

8.  $(x + 4)(x + 5) = 0$

9.  $(y - 3)(y + 6) = 0$

*Answers can be found on page 67.*

**Factoring Quadratic Equations**

Okay, so now we understand *why* we want to factor a quadratic expression, but *how* do we do it? It's not easy to look at  $x^2 + 3x - 10$  and see that it equals  $(x - 5)(x + 2)$ .

To get started, try solving the puzzle below. (Hint: It involves addition and multiplication.) We've done the first two for you:

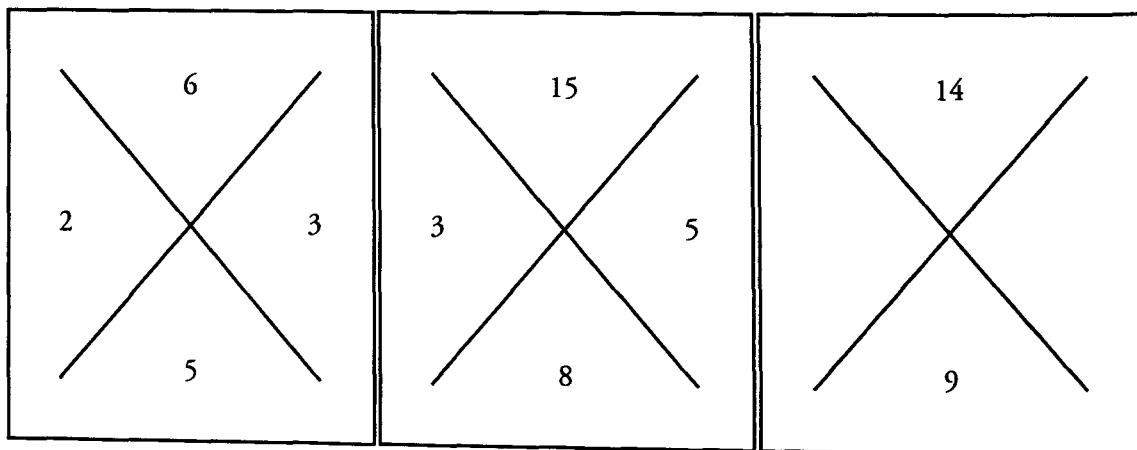

Have you figured out the trick to this puzzle? The answers are on the next page.



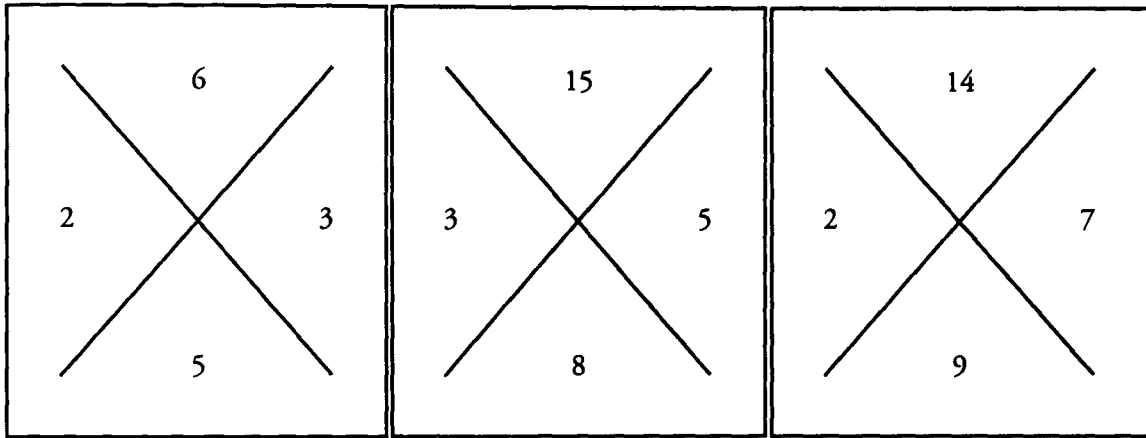

The way the diamonds work is that you multiply the two numbers on the sides to obtain the top number, and you add them to arrive at the bottom number.

Let's take another look at the connection between  $(x + 2)(x + 3)$  and  $x^2 + 5x + 6$ .

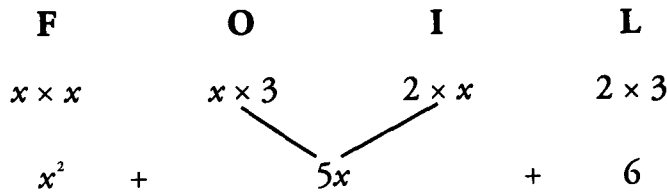

The 2 and the 3 play two important roles in building the quadratic expression:

1. They multiply together to give us 6, which is the final term in our quadratic expression.
2. Multiplying the outside terms gives us  $3x$ , and multiplying the inside terms gives us  $2x$ . We can then add those terms to give us  $5x$ , the middle term of our quadratic expression.

So when we are trying to factor a quadratic expression such as  $x^2 + 5x + 6$ , the key is to find the two numbers whose product equals the final term (6) and whose sum equals the coefficient of the middle term (the 5 in  $5x$ ). In this case, the two numbers that multiply to 6 and add up to 5 are 2 and 3:  $2 \times 3 = 6$  and  $2 + 3 = 5$ .

So the diamond puzzle is just a visual representation of this same goal. For any quadratic expression, take the final term (the **constant**) and place it in the top portion of the diamond. Take the **coefficient** of the middle term (in this case, the "5" in " $5x$ ") and place it in the lower portion of the diamond. For instance, if the middle term is  $5x$ , take the 5 and place it at the bottom of the diamond. Let's walk through the entire process with a new example:  $x^2 + 7x + 12$ .

The final term is 12, and the coefficient of the middle term is 7, so our diamond will look like this:

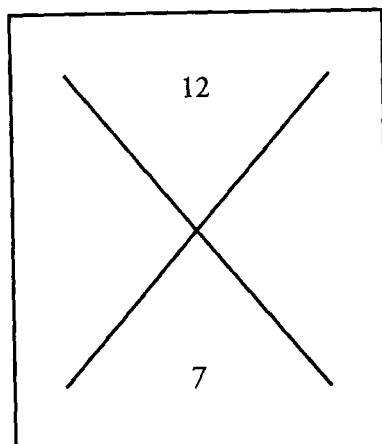

When we factor quadratics (or solve the diamond puzzle), it is better to focus first on determining which numbers could multiply to the final term. The reason is that these problems typically deal only with integers, and there are far fewer pairs of integers that will multiply to a certain product than will add to a certain sum. For instance, in this problem, there are literally an infinite number of integer pairs that can add to 7 (remember, negative numbers are also integers:  $-900,000$  and  $900,007$  sum to 7, for instance). On the other hand, there are only a few integer pairs that multiply to 12. We can actually list them all out: 1 & 12, 2 & 6, and 3 & 4. 1 and 12 sum to 13, so they don't work. 2 and 6 sum to 8, so they don't work either. 3 and 4 sum to 7, so this pair of numbers is the one we want. So our completed diamond looks like this:

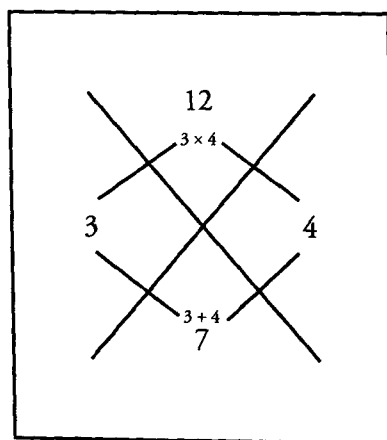

Now, because our numbers are 3 and 4, the factored form of our quadratic expression becomes  $(x + 3)(x + 4)$ .

Note: if we are factoring  $x^2 + 7x + 12 = 0$ , we get  $(x + 3)(x + 4) = 0$ , so our solutions are **NEGATIVE 3** and **NEGATIVE 4**, not 3 and 4 themselves. Remember, if we have  $(x + 3)(x + 4) = 0$ , then either  $x + 3 = 0$  or  $x + 4 = 0$ .

Let's try another example with one important difference. Solve the diamond puzzle for this quadratic expression:  $x^2 - 9x + 18$ . Now our diamond looks like this:

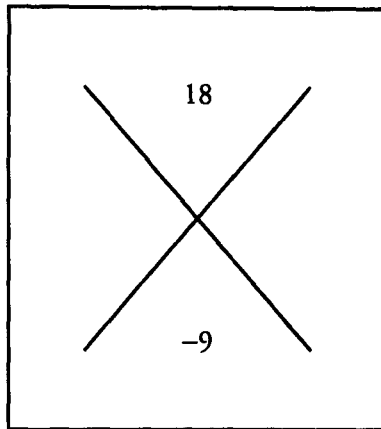

Now we need two numbers that multiply to positive 18, but sum to  $-9$ . Here, we know the product is positive, but the sum is negative. So when the top number is positive and the bottom number is negative, the 2 numbers we are looking for will both be negative.

Once again, it will be easier to start by figuring out what pairs of numbers can multiply to 18. In this case, three different pairs all multiply to 18:  $-1$  &  $-18$ ,  $-2$  &  $-9$ , and  $-3$  &  $-6$ . The pair  $-3$  &  $-6$ , however, is the only pair of numbers that also sums to  $-9$ , so this is the pair we want. We fill in the missing numbers, and our diamond becomes:

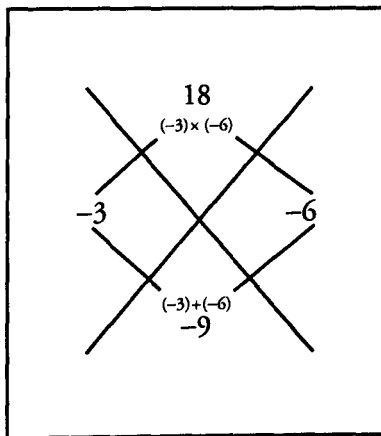

Now, if our numbers on the left and right of the diamond are  $-3$  and  $-6$ , the factored form of our quadratic expression becomes  $(x - 3)(x - 6)$ .

To recap, when the final term of the quadratic is positive, the two numbers we are looking for will either both be positive or both be negative. If the middle term is positive, as in the case of  $x^2 + 7x + 12$ , the numbers will both be positive (3 and 4). If the middle term is negative, as in the case of  $x^2 - 9x + 18$ , the numbers will both be negative ( $-3$  and  $-6$ ).

**Check Your Skills**

Factor the following quadratic expressions. (Explanations will include diamond puzzle.)

10.  $x^2 + 14x + 33$

11.  $x^2 - 14x + 45$

*Answers can be found on page 68.*

In the previous section we dealt with quadratic equations in which the final term was positive. Now we need to discuss how to deal with quadratics in which the final term is negative. The basic method is the same, although there is one important twist.

Take a look at the quadratic expression  $x^2 + 3x - 10$ . Let's start by creating our diamond.

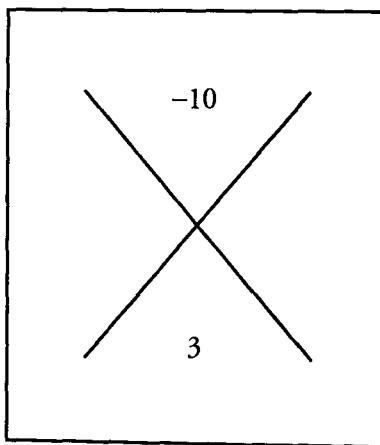

We are looking for two numbers that will multiply to  $-10$ . The only way for the product of two numbers to be negative is for one of them to be positive and one of them to be negative. That means that in addition to figuring out pairs of numbers that multiply to 10, we also need to worry about which number will be positive and which will be negative. Let's disregard the signs for the moment. There are only 2 pairs of integers that multiply to 10: 1 & 10 and 2 & 5. Let's start testing out the pair 1 & 10, and see what we can learn.

Let's try making 1 positive and 10 negative. If that were the case, our factored form of the expression would be  $(x + 1)(x - 10)$ . Let's FOIL it out and see what it would look like.

<b>F</b>		<b>O</b>		<b>I</b>		<b>L</b>
$x \times x$		$x \times -10$		$1 \times x$		$1 \times -10$
$x^2$		$-10x$		$1x$		$-10$
		\		/		
$x^2$	-	$9x$		-		$10$

The sum of 1 and  $-10$  is  $-9$ , but we want 3. That's not correct, so let's try reversing the signs. Now we'll see what happens if we make 1 negative and 10 positive. Our factored form would now be  $(x - 1)(x + 10)$ . Once again, let's FOIL it out.

<b>F</b>		<b>O</b>		<b>I</b>		<b>L</b>
$x \times x$		$x \times 10$		$-1 \times x$		$(-1) \times 10$
$x^2$		$10x$		$-x$		$-10$
		\		/		
$x^2$	+	$9x$		-		$10$

Again, this doesn't match our target. The sum of  $-1$  and  $10$  is not  $3$ . Compare these examples to the examples in the last section. Notice that, with our examples in the last section, the two numbers summed to the coefficient of the middle term (in our example  $x^2 + 7x + 12$ , the two numbers we wanted,  $3$  and  $4$ , summed to  $7$ , which is the coefficient of the middle term). In these two examples, however, because one number was positive and one number was negative, it is actually the *difference* of  $1$  and  $10$  that gave us the coefficient of the middle term.

We'll discuss this further as we continue with our example. For now, to factor quadratics in which the final term is negative, we actually ignore the sign initially and look for two numbers that multiply to the coefficient of the final term (ignoring the sign) and whose *difference* is the coefficient of the middle term (ignoring the sign).

Back to our example. The pair of numbers  $1$  and  $10$  did not work, so let's look at the pair  $2$  and  $5$ . Notice that the coefficient of the middle term is  $3$ . And the difference of  $2$  and  $5$  is  $3$ . This has to be the correct pair, so all we need to do is determine whether our factored form is  $(x + 2)(x - 5)$  OR  $(x - 2)(x + 5)$ . Take some time now to FOIL both expressions and figure out which one is correct. We'll discuss the correct answer on the next page.

You should have come to the conclusion that  $(x - 2)(x + 5)$  was the correctly factored form of the expression. That means our diamond looks like this:

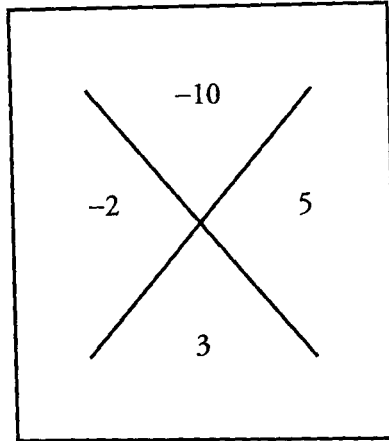

To recap, the way to factor *any* quadratic expression where the final term is negative is as follows:

1. Ignore the signs initially. Find a pair of numbers that multiply to the coefficient of the final term and whose *difference* is the coefficient of the middle term (for  $x^2 + 3x - 10$ , the numbers 2 and 5 multiply to 10 and  $5 - 2 = 3$ ).
2. Now that you have the pair of numbers (2 and 5) you need to figure out which one will be positive and which one will be negative. As it turns out, this is straightforward to do. We pay attention to signs again. If the sign of the middle term is positive, then the larger of the two numbers will be positive, and the smaller will be negative. This was the case in our previous example. The middle term was  $+3$ , so our pair of numbers was  $+5$  and  $-2$ . On the other hand, when the middle term is negative, the larger number will be negative, and the smaller number will be positive.

Let's work through one more example to see how this works. What is the factored form of  $x^2 - 4x - 21$ ? Take some time to work through it for yourself, and we'll go through it together on the next page.

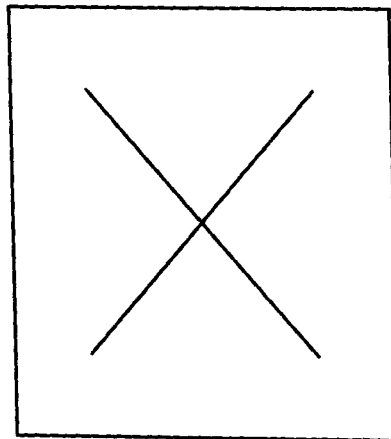

First let's start our diamond. It looks like this:

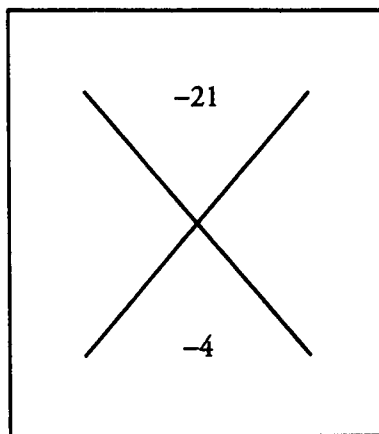

Because the coefficient of the final term ( $-21$ ) is negative, we're going to ignore the signs for the moment, and focus on finding pairs of integers that will multiply to 21. The only possible pairs are 1 and 21, and 3 and 7. Next, we take the difference of both pairs.  $21 - 1 = 20$ , and  $7 - 3 = 4$ . Our second pair matches the  $-4$  on the bottom of the diamond (because we are ignoring the sign of the  $-4$  at this stage) so 3 and 7 is the correct pair of numbers.

Now all that remains is to determine the sign of each. The coefficient of the middle term ( $-4$ ) is negative, so we need to assign the negative sign to the larger of the two numbers, 7. That means that the 3 will be positive. So the correctly factored form of our quadratic expression is  $(x + 3)(x - 7)$ .

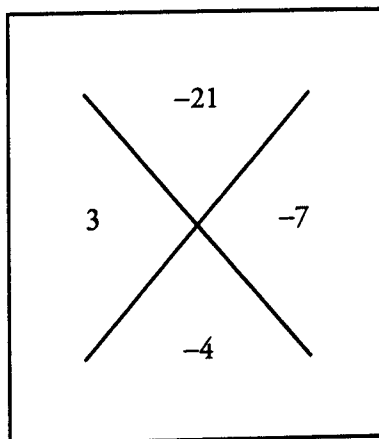

### Check Your Skills

Factor the following expressions:

12.  $x^2 + 3x - 18$

13.  $x^2 - 5x - 66$

*Answers can be found on page 69.*

## Solving Quadratic Equations

Now that we know how to factor quadratic expressions, it's time to make that final jump to actually solving quadratic equations. When we first discussed factoring, we noted that when one side of the equation is equal to 0, we can make use of the rule that anything times 0 is 0. In the case of the equation  $(x - 5)(x + 10) = 0$ , we know that either  $(x - 5) = 0$  or  $(x + 10) = 0$ , which means that  $x = 5$  OR  $-10$ .

The whole point of factoring quadratic equations is so that we can make use of this rule. That means that, before you factor a quadratic expression, you **MUST** make sure that the other side of the equation equals 0.

Suppose you see an equation  $x^2 + 10x = -21$ , and you need to solve for  $x$ . The  $x^2$  term in the equation should tell you that this is a quadratic equation, but it's not yet ready to be factored. Before it can be factored, you have to move everything to one side of the equation. In this equation, the easiest way to do that is to add 21 to both sides, giving you  $x^2 + 10x + 21 = 0$ . Now that one side equals 0, you're ready to factor.

The final term is positive, so we're looking for 2 numbers to multiply to 21 and sum to 10. 3 & 7 fit the bill, so our factored form is  $(x + 3)(x + 7) = 0$ . That means that  $x = -3$  OR  $-7$ .

And now you know all the steps to successfully factoring and solving quadratic equations.

### Check Your Skills

Solve the following quadratic equations

14.  $x^2 - 3x + 2 = 0$

15.  $x^2 + 2x - 35 = 0$

16.  $x^2 - 15x = -26$

*Answers can be found on pages 69–70.*

## Using FOIL with Square Roots

Some GRE problems ask you to solve factored expressions that involve roots. For example, the GRE might ask you to solve the following:

What is the value of  $(\sqrt{8} - \sqrt{3})(\sqrt{8} + \sqrt{3})$ ?

Even though these problems do not involve any variables, you can solve them just like you would solve a pair of quadratic factors: use FOIL.

FIRST:  $\sqrt{8} \times \sqrt{8} = 8$

OUTER:  $\sqrt{8} \times \sqrt{3} = \sqrt{24}$

INNER:  $\sqrt{8} \times (-\sqrt{3}) = -\sqrt{24}$

LAST:  $(-\sqrt{3})(\sqrt{3}) = -3$

The 4 terms are:  $8 + \sqrt{24} - \sqrt{24} - 3$ .

We can simplify this expression by removing the two middle terms (they cancel each other out) and subtracting:  $8 + \sqrt{24} - \sqrt{24} - 3 = 8 - 3 = 5$ . Although the problem looks complex, using FOIL reduces the entire expression to 5.

### Check Your Skills

17. FOIL  $(\sqrt{8} - \sqrt{2})(\sqrt{8} - \sqrt{2})$

*Answer can be found on page 70.*



## One-Solution Quadratics

Not all quadratic equations have two solutions. Some have only one solution. One-solution quadratics are also called **perfect square** quadratics, because both roots are the same. Consider the following examples:

$$\begin{aligned}x^2 + 8x + 16 &= 0 && \text{Here, the one solution for } x \text{ is } -4. \\(x + 4)(x + 4) &= 0 \\(x + 4)^2 &= 0\end{aligned}$$

$$\begin{aligned}x^2 - 6x + 9 &= 0 && \text{Here, the one solution for } x \text{ is } 3. \\(x - 3)(x - 3) &= 0 \\(x - 3)^2 &= 0\end{aligned}$$

Be careful not to assume that a quadratic equation always has two solutions. Always factor quadratic equations to determine their solutions. In doing so, you will see whether a quadratic equation has one or two solutions.

### Check Your Skills

18. Solve for  $x$ :  $x^2 - 10x + 25 = 0$

*Answer can be found on page 70.*

## Zero in the Denominator: Undefined

Math convention does not allow division by 0. When 0 appears in the denominator of an expression, then that expression is undefined. How does this convention affect quadratic equations? Consider the following:

What are the solutions to the following equation?

$$\frac{x^2 + x - 12}{x - 2} = 0$$

We notice a quadratic equation in the numerator. Since it is a good idea to start solving quadratic equations by factoring, we will factor this numerator as follows:

$$\frac{x^2 + x - 12}{x - 2} = 0 \rightarrow \frac{(x - 3)(x + 4)}{x - 2} = 0$$

If either of the factors in the numerator is 0, then the entire expression becomes 0. Thus, the solutions to this equation are  $x = 3$  or  $x = -4$ .

Note that making the denominator of the fraction equal to 0 would NOT make the entire expression equal to 0. Recall that if 0 appears in the denominator, the expression becomes undefined. Thus,  $x = 2$  (which would make the denominator equal to 0) is NOT a solution to this equation. In fact, since setting  $x$  equal to 2 would make the denominator 0, the value 2 is not allowed:  **$x$  cannot equal 2.**

### Check Your Skills

19. Solve for  $x$ :  $\frac{(x+1)(x-2)}{(x-4)} = 0$

*Answer can be found on page 71.*

## The Three Special Products

Three quadratic expressions called *special products* come up so frequently on the GRE that it pays to memorize them. You should immediately recognize these 3 expressions and know how to factor (or distribute) each one automatically. This will usually put you on the path toward the solution to the problem.

Special Product #1:  $x^2 - y^2 = (x + y)(x - y)$

Special Product #2:  $x^2 + 2xy + y^2 = (x + y)(x + y) = (x + y)^2$

Special Product #3:  $x^2 - 2xy + y^2 = (x - y)(x - y) = (x - y)^2$

You should be able to identify these products when they are presented in disguised form. For example,  $a^2 - 1$  can be factored as  $(a + 1)(a - 1)$ . Similarly,  $(a + b)^2$  can be distributed as  $a^2 + 2ab + b^2$ .

Avoid the following common mistakes with special products:

Wrong:  $(x + y)^2 = x^2 + y^2$  ?  
 $(x - y)^2 = x^2 - y^2$  ?

Right:  $(x + y)^2 = x^2 + 2xy + y^2$   
 $(x - y)^2 = x^2 - 2xy + y^2$

### Check Your Skills

Factor the following:

20.  $4a^2 + 4ab + b^2 = 0$

21.  $x^2 + 22xy + 121y^2 = 0$

*Answers can be found on page 71.*

**Check Your Skills Answer Key:**

1.  $x^2 + 13x + 36: (x + 4)(x + 9)$

$(x + 4)(x + 9)$

F – multiply the first term in each parentheses:  $x \times x = x^2$ 

$(x + 4)(x + 9)$

O – multiply the outer term in each:  $x \times 9 = 9x$ 

$(x + 4)(x + 9)$

I – multiply the inner term in each:  $4 \times x = 4x$ 

$(x + 4)(x + 9)$

L – multiply the last term in each:  $4 \times 9 = 36$ 

$x^2 + 9x + 4x + 36 \rightarrow x^2 + 13x + 36$

2.  $y^2 - 3y - 18: (y + 3)(y - 6)$

$(y + 3)(y - 6)$

F – multiply the first term in each parentheses:  $y \times y = y^2$ 

$(y + 3)(y - 6)$

O – multiply the outer term in each:  $y \times -6 = -6y$ 

$(y + 3)(y - 6)$

I – multiply the inner term in each:  $3 \times y = 3y$ 

$(y + 3)(y - 6)$

L – multiply the last term in each:  $3 \times -6 = -18$ 

$y^2 - 6y + 3y - 18 \rightarrow y^2 - 3y - 18$

3.  $x^2 + 10x + 21: (x + 7)(3 + x)$

$(x + 7)(3 + x)$

F – multiply the first term in each parentheses:  $x \times 3 = 3x$ 

$(x + 7)(3 + x)$

O – multiply the outer term in each:  $x \times x = x^2$ 

$(x + 7)(3 + x)$

I – multiply the inner term in each:  $7 \times 3 = 21$ 

$(x + 7)(3 + x)$

L – multiply the last term in each:  $7 \times x = 7x$ 

$3x + x^2 + 21 + 7x \rightarrow x^2 + 10x + 21$

4.  $4 + 8t$

$4(1 + 2t)$

Factor out a 4

5.  $5x + 25y$

$5(x + 5y)$

Factor out a 5

6.  $2x^2 + 16x^3$

$2x^2(1 + 8x)$

Factor out a  $2x^2$ 

7.  $x = 2$  OR  $1: (x - 2)(x - 1) = 0$

$(x - 2) = 0 \rightarrow x = 2$

Remove the parentheses and solve for  $x$ 

OR  $(x - 1) = 0 \rightarrow x = 1$

Remove the parentheses and solve for  $x$ 

8.  $x = -4$  OR  $-5: (x + 4)(x + 5) = 0$

$(x + 4) = 0 \rightarrow x = -4$

Remove the parentheses and solve for  $x$ 

OR  $(x + 5) = 0 \rightarrow x = -5$

Remove the parentheses and solve for  $x$ 

9.  $y = 3$  OR  $-6: (y - 3)(y + 6) = 0$

$(y - 3) = 0 \rightarrow y = 3$

Remove the parentheses and solve for  $y$ 

OR  $(y + 6) = 0 \rightarrow y = -6$

Remove the parentheses and solve for  $y$

10.  $(x + 3)(x + 11)$ :  $x^2 + 14x + 33$

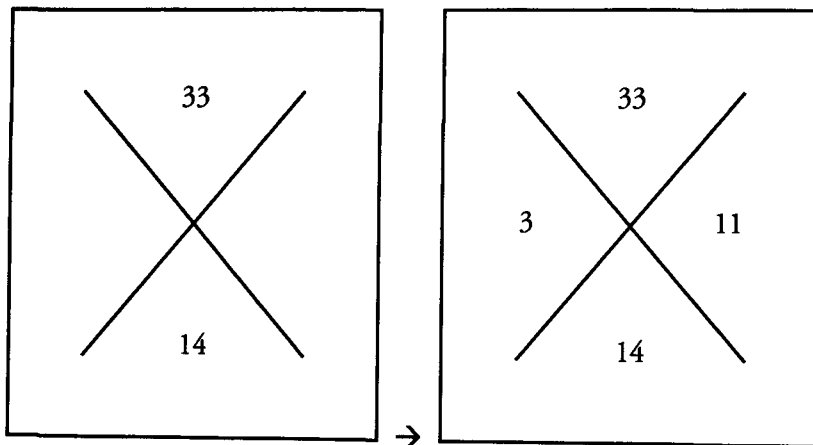

1 & 33 and 3 & 11 multiply to 33. 3 & 11 sum to 14  
 $(x + 3)(x + 11)$

11.  $(x - 5)(x - 9)$ :  $x^2 - 14x + 45$

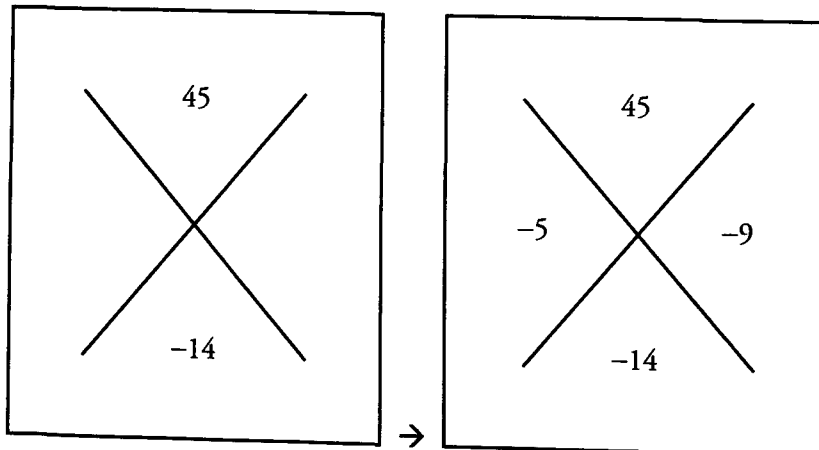

1 & 45, 3 & 15, and 5 & 9 multiply to 45. 5 & 9 sum to 14  
 $(x - 5)(x - 9)$

12.  $(x + 6)(x - 3): x^2 + 3x - 18$

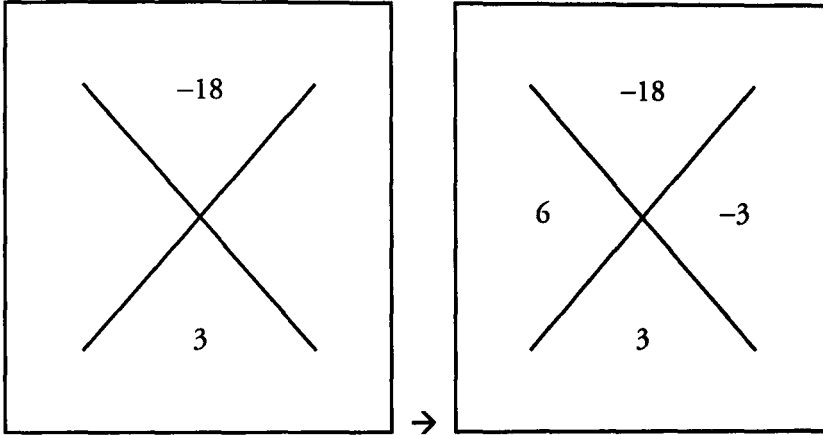

Middle term is positive, so the larger of the two numbers (6) is positive.  
 1 & 18, 2 & 9, and 3 & 6 multiply to 18. The difference of 3 & 6 is 3.  
 $(x + 6)(x - 3)$

13.  $(x + 6)(x - 11): x^2 - 5x - 66$

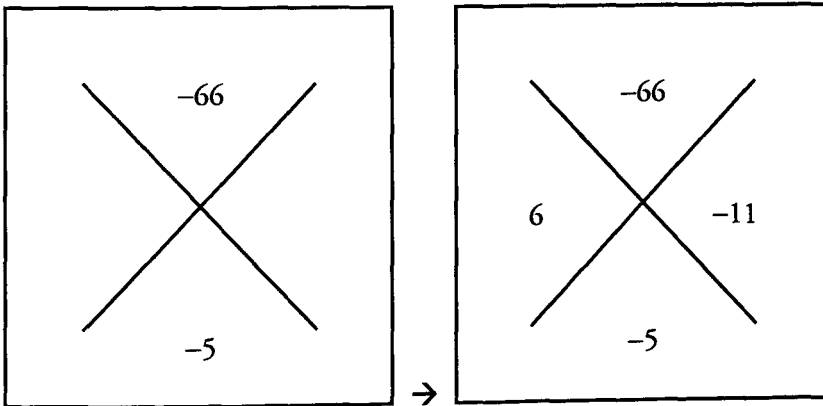

1 & 66, 2 & 33, 3 & 22, and 6 & 11 multiply to 66. The difference of 6 and 11 is 5.  
 $(x + 6)(x - 11)$

14.  $x = 1$  OR  $2: x^2 - 3x + 2 = 0$

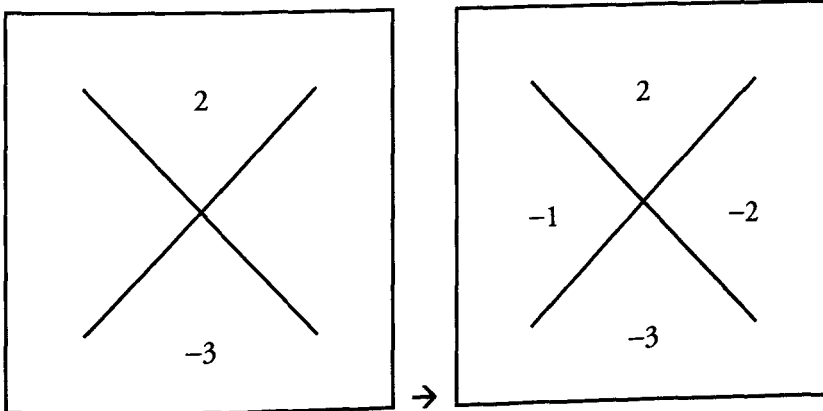

1 & 2 multiply to 2 and add to 3.  
 $(x - 1)(x - 2) = 0$

**Chapter 3**

**QUADRATIC EQUATIONS ANSWER KEY**

15.  $x = 5$  OR  $-7$ :  $x^2 + 2x - 35 = 0$

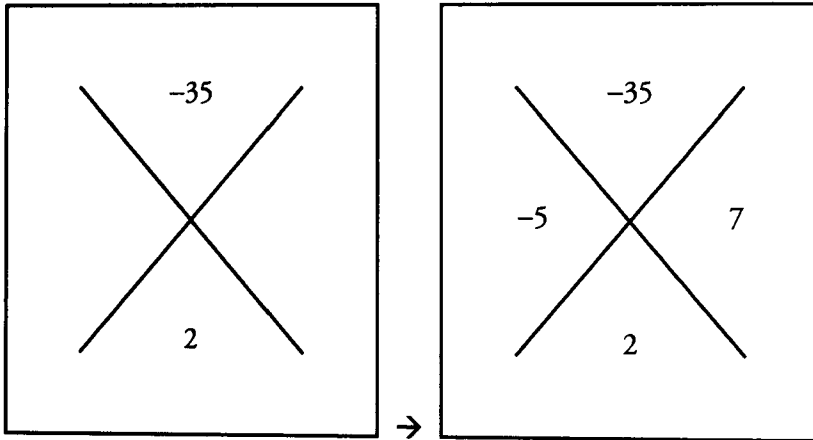

5 & 7 multiply to 35 and their difference is 2. Middle term is positive, so the larger of the two numbers (7) is positive.

$(x - 5)(x + 7) = 0$

16.  $x = 2$  OR  $13$ :  $x^2 - 15x = -26$   
 $x^2 - 15x + 26 = 0$

Add 26 to both sides so that the expression equals 0

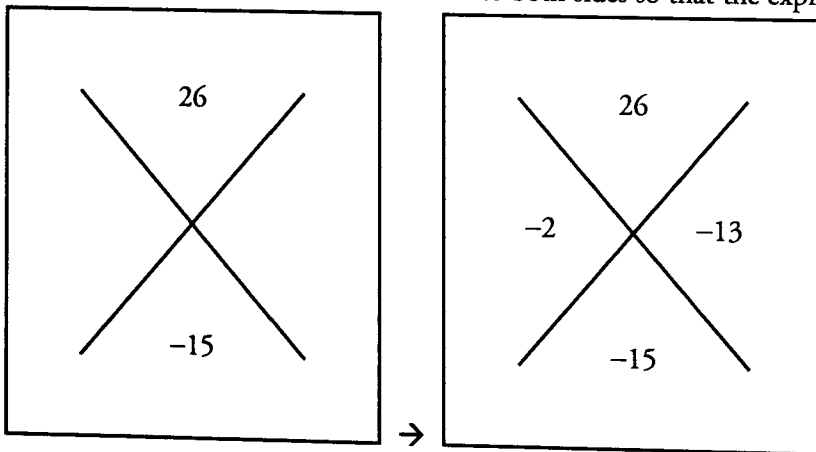

2 & 13 multiply to 26 and sum to 15  
 $(x - 2)(x - 13) = 0$

17. **2:** FOIL  $(\sqrt{8} - \sqrt{2})(\sqrt{8} - \sqrt{2})$

First:  $\sqrt{8} \times \sqrt{8} = 8$

Outside:  $\sqrt{8} \times (-\sqrt{2}) = -\sqrt{16} = -4$

Inside:  $(-\sqrt{2}) \times \sqrt{8} = -\sqrt{16} = -4$

Last:  $\sqrt{2} \times \sqrt{2} = 2$

Sum of FOIL terms:  $8 - 4 - 4 + 2 = 2$

18.  $x = 5$ :  $x^2 - 10x + 25 = 0$

$(x - 5)(x - 5) = 0$

$x = 5$

$$19. x = -1, 2; x \neq 4: \frac{(x+1)(x-2)}{(x-4)} = 0$$

The numerator is zero if either  $(x+1)$  or  $(x-2)$  is zero. Thus,  $x = -1$  or  $x = 2$ .  
But  $x \neq 4$ , because  $x = 4$  would make the fraction undefined.

$$20. (2a + b)^2 = 0: 4a^2 + 4ab + b^2 = 0 \rightarrow (2a + b)(2a + b) = 0$$

$$21. (x + 11y)^2 = 0: x^2 + 22xy + 121y^2 = 0 \rightarrow (x + 11y)(x + 11y) = 0$$

## Problem Set

Solve the following problems. Distribute and factor when needed.

- If  $-4$  is a solution for  $x$  in the equation  $x^2 + kx + 8 = 0$ , what is  $k$ ?
- If  $8$  and  $-4$  are the solutions for  $x$ , which of the following could be the equation?  
 (A)  $x^2 - 4x - 32 = 0$                       (B)  $x^2 - 4x + 32 = 0$                       (C)  $x^2 + 4x - 12 = 0$   
 (D)  $x^2 + 4x + 32 = 0$                       (E)  $x^2 + 4x + 12 = 0$
- Given that  $16 - y^2 = 10(4 + y)$ , what is  $y$ ?
- Given that  $x^2 - 10 = -1$ , what is  $x$ ?
- Given that  $x^2 - 13x = 30$ , what is  $x$ ?
- If the area of a certain square (expressed in square meters) is added to its perimeter (expressed in meters), the sum is  $77$ . What is the length of a side of the square?
- Hugo lies on top of a building, throwing pennies straight down to the street below. The formula for the height,  $H$ , that a penny falls is  $H = Vt + 5t^2$ , where  $V$  is the original velocity of the penny (how fast Hugo throws it when it leaves his hand) and  $t$  is equal to the time it takes to hit the ground. The building is  $60$  meters high, and Hugo throws the penny down at an initial speed of  $20$  meters per second. How long does it take for the penny to hit the ground?
- $(3 - \sqrt{7})(3 + \sqrt{7}) =$
- If  $x^2 - 6x - 27 = 0$  and  $y^2 - 6y - 40 = 0$ , what is the maximum value of  $x + y$ ?
- Given that  $x^2 - 10x + 25 = 16$ , what is  $x$ ?
- |                   |                     |                   |
|-------------------|---------------------|-------------------|
|                   | $x^2 - 2x - 15 = 0$ |                   |
| <b>Quantity A</b> |                     | <b>Quantity B</b> |
| $x$               |                     | $1$               |
- |                   |                      |                   |
|-------------------|----------------------|-------------------|
|                   | $x^2 - 12x + 36 = 0$ |                   |
| <b>Quantity A</b> |                      | <b>Quantity B</b> |
| $x$               |                      | $6$               |
- |                   |          |                   |
|-------------------|----------|-------------------|
|                   | $xy > 0$ |                   |
| <b>Quantity A</b> |          | <b>Quantity B</b> |
| $(x + y)^2$       |          | $(x - y)^2$       |



1.  $k = 6$ : If  $-4$  is a solution, then we know that  $(x + 4)$  must be one of the factors of the quadratic equation. The other factor is  $(x + ?)$ . We know that the product of 4 and ? must be equal to 8; thus, the other factor is  $(x + 2)$ . We know that the sum of 4 and 2 must be equal to  $k$ . Therefore,  $k = 6$ .

2. **A:** If the solutions to the equation are 8 and  $-4$ , the factored form of the equation is:

$$(x - 8)(x + 4) = 0$$

Distributed, this equals:  $x^2 - 4x - 32 = 0$ .

3.  $y = \{-4, -6\}$ : Simplify and factor to solve.

$$16 - y^2 = 10(4 + y)$$

$$16 - y^2 = 40 + 10y$$

$$y^2 + 10y + 24 = 0$$

$$(y + 4)(y + 6) = 0$$

$$y + 4 = 0 \quad \text{OR} \quad y + 6 = 0$$

$$y = -4 \quad \quad \quad y = -6$$

Notice that it is possible to factor the left-hand side of the equation first:  $16 - y^2 = (4 + y)(4 - y)$ . However, doing so is potentially dangerous: you may decide to then divide both sides of the equation by  $(4 + y)$ . You cannot do this, because it is possible that  $(4 + y)$  equals zero (and in fact, for one solution of the equation, it does!).

4.  $x = \{-3, 3\}$ :

$$x^2 - 10 = -1$$

$$x^2 = 9$$

$$x = \{-3, 3\}$$

5.  $x = \{15, -2\}$ :

$$x^2 - 13x = 30$$

$$x^2 - 13x - 30 = 0$$

$$(x + 2)(x - 15) = 0$$

$$x + 2 = 0 \quad \text{OR} \quad x - 15 = 0$$

$$x = -2 \quad \text{OR} \quad x = 15$$

6.  $s = 7$ : The area of the square =  $s^2$ . The perimeter of the square =  $4s$ .

$$s^2 + 4s = 77$$

$$s^2 + 4s - 77 = 0$$

$$(s + 11)(s - 7) = 0$$

$$s + 11 = 0 \quad \text{OR} \quad s - 7 = 0$$

$$s = -11 \quad \quad \quad s = 7$$

Since the edge of a square must be positive, discard the negative value for  $s$ .

7.  $t = 2$ :

$$\begin{aligned}
 H &= Vt + 5t^2 \\
 60 &= 20t + 5t^2 \\
 5t^2 + 20t - 60 &= 0 \\
 5(t^2 + 4t - 12) &= 0 \\
 5(t + 6)(t - 2) &= 0 \\
 t + 6 = 0 \quad \text{OR} \quad t - 2 = 0 \\
 t = -6 \quad \quad \quad t = 2
 \end{aligned}$$

Since a time must be positive, discard the negative value for  $t$ .

8. 2: Use FOIL to simplify this product:

$$\begin{aligned}
 F: 3 \times 3 &= 9 \\
 O: 3 \times \sqrt{7} &= 3\sqrt{7} \\
 I: -\sqrt{7} \times 3 &= -3\sqrt{7} \\
 L: \sqrt{7} \times \sqrt{7} &= -7 \\
 9 + 3\sqrt{7} - 3\sqrt{7} - 7 &= 2
 \end{aligned}$$

9. 19: Factor both quadratic equations. Then, use the largest possible values of  $x$  and  $y$  to find the maximum value of the sum  $x + y$ .

$$\begin{aligned}
 x^2 - 6x - 27 &= 0 & y^2 - 6y - 40 &= 0 \\
 (x + 3)(x - 9) &= 0 & (y + 4)(y - 10) &= 0 \\
 x + 3 = 0 \quad \text{OR} \quad x - 9 = 0 & & y + 4 = 0 \quad \text{OR} \quad y - 10 = 0 \\
 x = -3 \quad \quad \quad x = 9 & & y = -4 \quad \quad \quad y = 10
 \end{aligned}$$

The maximum possible value of  $x + y = 9 + 10 = 19$ .

10.  $x = \{1, 9\}$ :

$$\begin{aligned}
 x^2 - 10x + 25 &= 16 \\
 x^2 - 10x + 9 &= 0 \\
 (x - 9)(x - 1) &= 0 \\
 x - 9 = 0 \quad \text{OR} \quad x - 1 = 0 \\
 x = 9 \quad \quad \quad x = 1
 \end{aligned}$$

11. D: First factor the equation in the common information.

$$\begin{aligned}
 x^2 - 2x - 15 = 0 &\rightarrow (x - 5)(x + 3) = 0 \\
 x = 5 \text{ OR } x = -3
 \end{aligned}$$

$$x^2 - 2x - 15 = 0$$

Quantity A  
 $x = 5$  OR  $-3$

Quantity B  
 1

$x$  could be greater than or less than 1. **We don't have enough information.**

12. C: First factor the equation in the common information.

$$x^2 - 12x + 36 = 0 \rightarrow (x - 6)(x - 6) = 0$$

$$x = 6$$

$$x^2 - 12x + 36 = 0$$

**Quantity A**

$$x = 6$$

**Quantity B**

$$6$$

The quantities are equal.

13. A: Expand the expressions in both columns.

$$xy > 0$$

**Quantity A**

$$(x + y)^2 =$$

$$x^2 + 2xy + y^2$$

**Quantity B**

$$(x - y)^2 =$$

$$x^2 - 2xy + y^2$$

Now subtract  $x^2 + y^2$  from both columns.

$$xy > 0$$

**Quantity A**

$$\begin{array}{r} x^2 + 2xy + y^2 \\ -(x^2 + y^2) \\ \hline 2xy \end{array}$$

**Quantity B**

$$\begin{array}{r} x^2 - 2xy + y^2 \\ -(x^2 + y^2) \\ \hline -2xy \end{array}$$

$xy$  is positive, so the value in Quantity A will be positive, regardless of the values of  $x$  and  $y$ . Similarly, the value in Quantity B will always be negative, regardless of the values of  $x$  and  $y$ .

**Quantity A is larger.**

g

**Chapter 4**  
*of*

ALGEBRA

**INEQUALITIES &  
ABSOLUTE VALUES**

## In This Chapter . . .

---

# g

- Solving Inequalities
- Absolute Value — Distance on the Number Line
- Putting Them Together: Inequalities and Absolute Values
- Manipulating Compound Inequalities
- Using Extreme Values
- Optimization Problems
- Summary of Inequality Techniques

## INEQUALITIES

Earlier we explored how to solve equations. Now let's look at how we can solve *inequalities*.

Inequalities are expressions that use  $<$ ,  $>$ ,  $\leq$  or  $\geq$  to describe the relationship between two values.

*Examples of inequalities:*

$$5 > 4 \qquad y \leq 7 \qquad x < 5 \qquad 2x + 3 \geq 0$$

The table below illustrates how the various inequality symbols are translated. Notice that when we translate these inequalities, we read from left to right.

$x < y$	$x$ is less than $y$	
$x > y$	$x$ is greater than $y$	
$x \leq y$	$x$ is less than or equal to $y$	$x$ is at most $y$
$x \geq y$	$x$ is greater than or equal to $y$	$x$ is at least $y$

We can also have two inequalities in one statement (sometimes called **compound inequalities**):

$9 < g < 200$	9 is less than $g$ , and $g$ is less than 200
$-3 < y \leq 5$	-3 is less than $y$ , and $y$ is less than or equal to 5
$7 \geq x > 2$	7 is greater than or equal to $x$ , and $x$ is greater than 2

To visualize an inequality, it is helpful to represent it on a number line:

### Example 1

$$y > 5$$

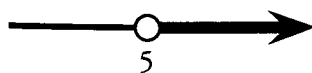

Note: 5 is *not* included in the line (as shown by the circle *around* 5), because it is not a part of the solution— $y$  is greater than 5, but not equal to 5.

### Example 2

$$b \leq 2$$

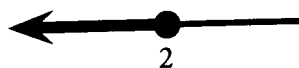

Here, 2 is included in the solution, (as shown by the solid circle at 2) because  $b$  can equal 2.

Visually, any number covered by the black arrow will make the inequality true and so is a possible solution to the inequality. Conversely, any number not covered by the black arrow will make the inequality untrue and is not a solution.

### Check Your Skills

Represent the following equations on the number line provided:

1.  $x > 3$

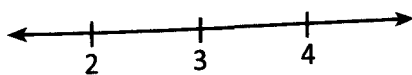

2.  $b \geq -2$

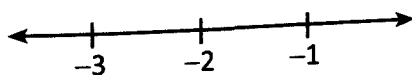

3.  $y = 4$

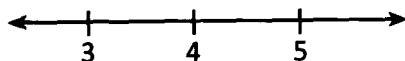

Translate the following into inequality statements:

4.  $z$  is greater than  $v$ .  
 5. The total amount is greater than \$2,000.

*Answers can be found on page 95.*

## Solving Inequalities

*What does it mean to “solve an inequality”?*

You may be asking yourself, “I know what it means to solve an equation (such as  $x = 2$ ), but what does it mean to solve an inequality?” Essentially, the principle is the same.

A solution is a number that makes an equation or inequality true. When you plug a solution back into the original equation or inequality, you get a *true statement*. This idea works the same for both equations and inequalities.

However, equations have only one, or just a few, values as solutions, but inequalities give a whole *range* of values as solutions—way too many to list individually.

Here’s an example to help illustrate:

**Equation:**  $x + 3 = 8$

The solution to  $x + 3 = 8$  is  $x = 5$ .  
 5 is the **only** number that will make the equation true.

Plug back in to check:  
 $5 + 3 = 8$ . True.

**Inequality:**  $x + 3 < 8$

The solution to  $x + 3 < 8$  is  $x < 5$ . Now, 5 itself is not a solution because  $5 + 3 < 8$  is not a true statement. But, 4 is a solution because  $4 + 3 < 8$  is true. For that matter, 4.99, 3, 2, 2.87,  $-5$ , and  $-100$  are all also solutions. And the list goes on. Whichever of the correct answers you plug in, you need to arrive at something that looks like:

(Any number less than 5)  $+ 3 < 8$ . True.

### Check Your Skills

6. Which of the following numbers are solutions to the inequality  $x < 10$ ?

Indicate all that apply.

- A  $-3$   
 B  $2.5$   
 C  $-3/2$   
 D  $9.999$

*Answer can be found on page 95.*

**Cleaning Up Inequalities**

As with equations, our objective is to isolate our variable on one side of the inequality. When the variable is by itself, it is easiest to see what the solution (or range of solutions) really is. Although  $2x + 6 < 12$  and  $x < 3$  provide the same information (the second inequality is a simplified form of the first), we understand the full range of solutions much more easily when we look at the second inequality, which literally tells us that “ $x$  is less than 3.”

Fortunately, the similarities between equations and inequalities don't end there—the techniques we will be using to clean up inequalities are the same that we used to clean up equations. (We will discuss one important difference shortly.)

**Inequality Addition and Subtraction**

If we told you that  $x = 5$ , what would  $x + 3$  equal?  $x + 3 = (5) + 3$ , or  $x + 3 = 8$ . In other words, if we add the same number to both sides of an equation, the equation is still true.

The same holds true for inequalities. If we add or subtract the same number from both sides of an inequality, the inequality remains true.

*Example 1*

$$\begin{array}{r} a - 4 > 6 \\ +4 \quad +4 \\ \hline a > 10 \end{array}$$

*Example 2*

$$\begin{array}{r} y + 7 < 3 \\ -7 \quad -7 \\ \hline y < -4 \end{array}$$

We can also add or subtract variables from both sides of an inequality. There is no difference between adding/subtracting numbers and adding/subtracting variables.

$$\begin{array}{r} 3 - y > 0 \\ +y \quad +y \\ \hline 3 > y \end{array}$$

**Check Your Skills**

Isolate the variable in the following inequalities.

7.  $x - 6 < 13$

8.  $y + 11 \geq -13$

9.  $x + 7 > 7$

*Answers can be found on page 95.*



**Inequality Multiplication and Division**

We can also use multiplication and division to isolate our variables, *as long as we recognize one very important distinction*. If we multiply or divide by a negative number, we must **switch the direction of the inequality sign**. If we are multiplying or dividing by a positive number, the direction of the sign stays the same.

Let's look at a couple of examples to illustrate.

**Multiplying or dividing by a POSITIVE number—the sign stays the same.**

Example 1

$$2x > 10$$

$$2x/2 > 10/2 \text{ Divide each side by 2}$$

$$x > 5$$

Example 2

$$z/3 \leq 2$$

$$z/3 \times (3) \leq 2 \times (3) \text{ Multiply each side by 3}$$

$$z \leq 6$$

In both instances, the sign remains the same because we are multiplying or dividing by a positive number.

**Multiplying or Dividing by a NEGATIVE Number—Switch the Sign!**

Example 1

$$-2x > 10$$

$$-2x/-2 > 10/-2 \text{ Divide each side by } -2$$

Switch the sign!

$$x < -5$$

Example 2

$$-4b \geq -8$$

$$-4b/-4 \geq -8/-4 \text{ Divide each side by } -4$$

Flip the inequality sign!

$$b \leq 2$$

Why do we do this? Take a look at the following example that illustrates why we need to switch the signs when multiplying or dividing by a negative number.

Incorrect if you DON'T switch		Switch the sign—Correct!	
$5 < 7$	TRUE	$5 < 7$	TRUE
$(-1) \times 5 < (-1) \times 7$	Multiply both sides by $-1$	$(-1) \times 5 < (-1) \times 7$	Multiply both sides by $-1$ AND switch the sign!
$-5 < -7$ !?!	NOT TRUE!	$-5 > -7$	STILL TRUE

In each case, we begin with a true inequality statement:  $5 < 7$  and then multiply by  $-1$ . We see that we have to switch the sign in order for the inequality statement to remain true.

What about multiplying or dividing an inequality by a *variable*? The short answer is... **try not to do it!** The issue is that you don't know the sign of the "hidden number" that the variable represents. If the variable has to be positive (e.g., it counts people or measures a length), then you can go ahead and multiply or divide.

If the variable must be negative, then you are also free to multiply or divide—just remember to flip the sign. However, if you don't know whether the variable is positive or negative, try to work through the problem with the inequality as-is. (If the problem is a Quantitative Comparison, consider whether not knowing the sign of the variable you want to multiply or divide by means that the answer is D!)

**Check Your Skills**

Isolate the variable in each equation.

10.  $x + 3 \geq -2$

11.  $-2y < 8$

12.  $a + 4 \geq 2a$

*Answers can be found on page 95.*

**Absolute Value—Distance on the Number Line**

The GRE adds another level of difficulty to equations and inequalities in the form of *absolute value*.

The “absolute value” of a number describes how far that number is away from 0. It is the distance between that number and 0 on a number line. The symbol for absolute value is  $|\text{number}|$ . For instance, we would write the absolute value of  $-5$  as  $|-5|$ .

Example 1: The absolute value of 5 is 5.

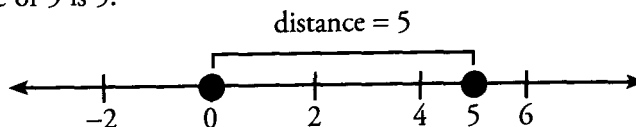

Example 2: The absolute value of  $-5$  is also 5.

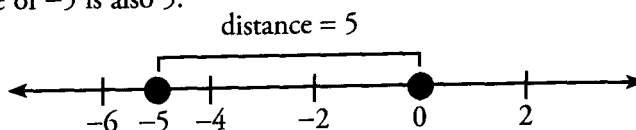

When you face an expression like  $|4 - 7|$ , treat the absolute value symbol like parentheses. Solve the arithmetic problem inside first, and then find the absolute value of the answer. In this case,  $4 - 7 = -3$ , and  $-3$  is 3 units from zero, so  $|4 - 7| = |-3| = 3$ .

**Check Your Skills**

Mark the following expressions as TRUE or FALSE.

13.  $|3| = 3$

14.  $|-3| = -3$

15.  $|3| = -3$

16.  $|-3| = 3$

17.  $|3 - 6| = 3$

18.  $|6 - 3| = -3$

*Answers can be found on page 95.*

**Solving Absolute Value Equations**

On the GRE, some absolute value equations place a variable inside the absolute value signs.

Example:  $|y| = 3$

What's the trap here? The trap is that there are two numbers, 3 and  $-3$ , that are 3 units away from 0. That means both of these numbers could be possible values for  $y$ . So how do we figure that out? Here, we can't. All we can say is that  $y$  could be either the positive value or the negative value;  $y$  is *either* 3 or  $-3$ .

When there is a variable inside an absolute value, you should look for the variable to have two possible values. Although you will not always be able to determine which of the two is the correct value, it is important to be able to find both values. Next we will go through a step-by-step process for finding all solutions to an equation that contains a variable inside an absolute value.

$$|y| = 3$$

Step 1: Isolate the absolute value expression on one side of the equation. In this case, the absolute value expression is already isolated.

$$+(y) = 3 \text{ or } -(y) = 3$$

Step 2: Take what's inside the absolute value sign and set up two equations. The first sets the positive value equal to the other side of the equation, and the second sets the negative value equal to the other side.

$$y = 3 \quad \text{or} \quad -y = 3$$

$$y = 3 \quad \text{or} \quad y = -3$$

Step 3: Solve both equations.

Note: We have two possible values for  $y$ .

Sometimes people take a shortcut and go right to " $y$  equals plus or minus 3." This shortcut works as long as the absolute value expression is by itself on one side of the equation.

Here's a slightly more difficult problem, using the same technique:

Example:  $6 \times |2x + 4| = 30$

To solve this, you can use the same approach.

$$6 \times |2x + 4| = 30$$

$$|2x + 4| = 5$$

Step 1: Isolate the absolute value expression on one side of the equation or inequality.

$$(2x + 4) = 5 \quad \text{or} \quad -(2x + 4) = 5$$

$$2x + 4 = 5 \quad \text{or} \quad -2x - 4 = 5$$

Step 2: Set up two equations—the positive and the negative values are set equal to the other side.

$$2x = 1 \quad \text{or} \quad -2x = 9$$

Step 3: Solve both equations/inequalities.

$$x = 1/2 \quad \text{or} \quad x = -9/2$$

Note: We have two possible values for  $x$ .

**Check Your Skills**

Solve the following equations with absolute values in them:

19.  $|a| = 6$

20.  $|x + 2| = 5$

21.  $|3y - 4| = 17$

22.  $4|x + 1/2| = 18$

*Answers can be found on page 96.*

## Putting Them Together: Inequalities and Absolute Values

Some problems on the GRE include both inequalities and absolute values. We can solve these problems by combining what we have learned about solving inequalities with what we have learned about solving absolute values.

Example 1:  $|x| \geq 4$

Even though we're now dealing with an inequality, and not an equals sign, the basic process is the same. The absolute value is already isolated on one side, so now we need to set up our two equations or, in this case, inequalities. The first inequality replaces the absolute value with the *positive* of what's inside, and the second replaces the absolute value with the *negative* of what's inside.

$$+(x) \geq 4 \quad \text{or} \quad -(x) \geq 4$$

Now that we have our two equations, we isolate the variable in each equation.

$+(x) \geq 4$	$-(x) \geq 4$	
$x \geq 4$	$-x \geq 4$	Divide by $-1$
	$x \leq -4$	Remember to flip the sign when dividing by a negative

So the two solutions to the original equation are  $x \geq 4$  and  $x \leq -4$ . Let's represent that on a number line.

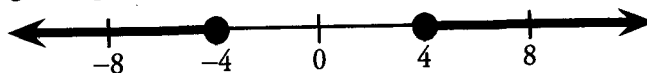

As before, any number that is covered by the black arrow will make the inequality true. Because of the absolute value, there are now two arrows instead of one, but nothing else has changed. Any number to the left of  $-4$  will make the inequality true, as will any number to the right of  $4$ .

Looking back at the inequality  $|x| \geq 4$ , we can now interpret it in terms of distance.  $|x| \geq 4$  means "x is at least 4 units away from zero, in either direction." The black arrows indicate all numbers for which that statement is true.

Example 2:  $|x + 3| < 5$

Once again, the absolute value is already isolated on one side, so now we need to set up our two equations. The first inequality replaces the absolute value with the *positive* of what's inside, and the second replaces the absolute value with the *negative* of what's inside.

$$+(x + 3) < 5 \quad \text{and} \quad -(x + 3) < 5$$

Next we isolate the variable in each equation.

$x + 3 < 5$	$-x - 3 < 5$
$x < 2$	$-x < 8$
	$x > -8$

So our two equations are  $x < 2$  and  $x > -8$ . But now something curious happens if we plot those two equations on our number line.

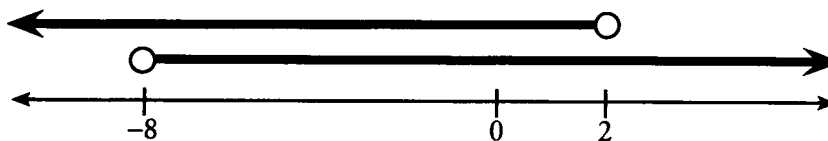

It seems like every number should be a solution to the equation. But if you start testing numbers, that isn't the case. Test out the number 5 for example. Is  $|5 + 3| < 5$ ? No, it isn't. As it turns out, the only numbers that make the original inequality true are those that are true for **both** inequalities. Really, our number line should look like this:



In our first example, it was the case that  $x$  could be greater than or equal to 4 OR less than or equal to  $-4$ . For this example, however, it seems to make more sense to say that  $x$  is greater than  $-8$  AND less than 2.

The inequality we just graphed means “ $(x + 3)$  is less than 5 units away from zero, in either direction.” The shaded segment indicates all numbers  $x$  for which this is true. As the inequalities become more complicated, don't worry about interpreting their meaning—simply solve them algebraically!

To summarize, when representing inequalities on the number line, absolute value expressions that are *greater than some quantity* will show up *as two ranges in opposite directions* (or “double arrows”); however, absolute value expressions that are *less than some quantity* will show up *as a single range* (or “line segment”).

### Check Your Skills

23.  $|x + 1| > 2$
24.  $|-x - 4| \geq 8$
25.  $|x - 7| < 9$

*Answers can be found on page 96.*

## Manipulating Compound Inequalities

Sometimes a problem with compound inequalities will require you to manipulate the inequalities in order to solve the problem. You can perform operations on a compound inequality as long as you remember to perform those operations on **every term** in the inequality, not just the outside terms. For example:

$$x + 3 < y < x + 5 \xrightarrow{\times} x < y < x + 2$$

**WRONG:** you must subtract 3 from EVERY term in the inequality

$$x + 3 < y < x + 5 \xrightarrow{\checkmark} x < y - 3 < x + 2$$

**CORRECT**

$$\frac{c}{2} \leq b - 3 \leq \frac{d}{2} \xrightarrow{\times} \leq c \leq b - 3 \leq d$$

**WRONG:** you must multiply by 2 in EVERY term in the inequality

$$\frac{c}{2} \leq b - 3 \leq \frac{d}{2} \xrightarrow{\checkmark} \leq c \leq 2b - 6 \leq d$$

**CORRECT**

If  $1 > 1 - ab > 0$ , which of the following must be true?

Indicate all that apply.

A  $\frac{a}{b} > 0$

B  $\frac{a}{b} < 1$

C  $ab < 1$

We can manipulate the original compound inequality as follows, making sure to perform each manipulation on every term:

$$1 > 1 - ab > 0$$

$$0 > -ab > -1$$

$$0 < ab < 1$$

Subtract 1 from all three terms

Multiply all three terms by  $-1$  and flip the inequality signs

Therefore we know that  $0 < ab < 1$ . This tells us that  $ab$  is positive, so  $\frac{a}{b}$  must be positive ( $a$  and  $b$  have the same sign). Therefore, A must be true. However, we do not know whether  $\frac{a}{b} < 1$ , so B is not necessarily true. But we do know that  $ab$  must be less than 1, so C must be true. Therefore, the correct answers are **A and C**.

### Check Your Skills

26. Find the range of values for  $x$  if  $-7 < 3 - 2x < 9$ .

*Answer can be found on page 97.*

## Using Extreme Values

One effective technique for solving GRE inequality problems is to focus on the EXTREME VALUES of a given inequality. This is particularly helpful when solving the following types of inequality problems:

- (1) Problems with multiple inequalities where the question involves the potential range of values for variables in the problem
- (2) Problems involving both equations and inequalities

### INEQUALITIES WITH RANGES

Whenever a question asks about the possible range of values for a problem, consider using extreme values:

Given that  $0 \leq x \leq 3$ , and  $y < 8$ , which of the following could NOT be the value of  $xy$ ?

- (A) 0   (B) 8   (C) 12   (D) 16   (E) 24

To solve this problem, consider the EXTREME VALUES of each variable.

#### Extreme Values for $x$

The lowest value for  $x$  is **0**.  
The highest value for  $x$  is **3**.

#### Extreme Values for $y$

The lowest value for  $y$  is negative infinity.  
The highest value for  $y$  is **less than 8**.

(Since  $y$  cannot be 8, we term this upper limit “less than 8” or “LT8” for shorthand.)

What is the lowest value for  $xy$ ? Plug in the lowest values for both  $x$  and  $y$ . In this problem,  $y$  has no lower limit, so there is no lower limit to  $xy$ .

What is the highest value for  $xy$ ? Plug in the highest values for both  $x$  and  $y$ . In this problem, the highest value for  $x$  is **3**, and the highest value for  $y$  is **LT8**.

Multiplying these two extremes together yields:  $3 \times \text{LT}8 = \text{LT}24$ . Notice that we can multiply LT8 by another number (as long as that other number is positive) just as though it were 8. We just have to remember to include the “LT” tag on the result.

Because the upper extreme for  $xy$  is less than 24,  $xy$  CANNOT be 24, and the answer is (E).

Notice that we would run into trouble if  $x$  did not have to be non-negative. Consider this slight variation:

Given that  $-1 \leq x \leq 3$ , and  $y < 8$ , what is the possible range of values for  $xy$ ?

Because  $x$  could be negative and because  $y$  could be a large negative number, there is no longer an upper extreme on  $xy$ . For example, if  $x = -1$  and  $y = -1,000$ , then  $xy = 1,000$ . Obviously, much larger results are possible for  $xy$  if both  $x$  and  $y$  are negative. Therefore,  $xy$  can equal any number.

## Check Your Skills

27. If  $-4 < a < 4$  and  $-2 < b < -1$ , which of the following could NOT be the value of  $ab$ ?

- (A) -3
- (B) 0
- (C) 4
- (D) 6
- (E) 9

*Answer can be found on page 97.*

## Optimization Problems

Related to extreme values are problems involving optimization: specifically, minimization or maximization problems. In these problems, you need to **focus on the largest and smallest possible values for each of the variables**, as some combination of them will usually lead to the largest or smallest possible result.

If  $-7 \leq a \leq 6$  and  $-7 \leq b \leq 8$ , what is the maximum possible value for  $ab$ ?

Once again, we are looking for a maximum possible value, this time for  $ab$ . We need to test the extreme values for  $a$  and for  $b$  to determine which combinations of extreme values will maximize  $ab$ :

Extreme Values for  $a$ 

The lowest value for  $a$  is  $-7$ .  
The highest value for  $a$  is  $6$ .

Extreme Values for  $b$ 

The lowest value for  $b$  is  $-7$ .  
The highest value for  $b$  is  $8$ .

Now let us consider the different extreme value scenarios for  $a$ ,  $b$ , and  $ab$ :

$a$		$b$		$ab$
Min	$-7$	Min	$-7$	$(-7) \times (-7) = 49$
Min	$-7$	Max	$8$	$(-7) \times 8 = -56$
Max	$6$	Min	$-7$	$6 \times (-7) = -42$
Max	$6$	Max	$8$	$6 \times 8 = 48$

This time,  $ab$  is maximized when we take the NEGATIVE extreme values for both  $a$  and  $b$ , resulting in  $ab = 49$ . Notice that we could have focused right away on the first and fourth scenarios, because they are the only scenarios which produce positive products.

If  $-4 \leq m \leq 7$  and  $-3 < n < 10$ , what is the maximum possible integer value for  $m - n$ ?

Again, we are looking for a maximum possible value, this time for  $m - n$ . We need to test the extreme values for  $m$  and for  $n$  to determine which combinations of extreme values will maximize  $m - n$ :



**Extreme Values for  $m$**

The lowest value for  $m$  is  $-4$ .  
The highest value for  $m$  is  $7$ .

**Extreme Values for  $n$**

The lowest value for  $n$  is greater than  $-3$ .  
The highest value for  $n$  is less than  $10$ .

Now let us consider the different extreme value scenarios for  $m$ ,  $n$ , and  $m - n$ :

	$m$		$n$		$m - n$
Min	$-4$	Min	GT( $-3$ )		$(-4) - \text{GT}(-3) = \text{LT}(-1)$
Min	$-4$	Max	LT $10$		$(-4) - \text{LT}10 = \text{GT}(-14)$
Max	$7$	Min	GT( $-3$ )		$7 - \text{GT}(-3) = \text{LT}10$
Max	$7$	Max	LT $10$		$7 - \text{LT}10 = \text{GT}(-3)$

$m - n$  is maximized when we take the POSITIVE extreme for  $m$  and the NEGATIVE extreme for  $n$ , resulting in  $m - n = \text{LESS THAN } 10$ . The largest integer less than  $10$  is  $9$ , so the correct answer is  $m - n = 9$ . Let's look at another, slightly different, problem.

If  $x \geq 4 + (z + 1)^2$ , what is the minimum possible value for  $x$ ?

The key to this type of problem—where we need to maximize or minimize when one of the variables has an even exponent—is to recognize that the squared term will be minimized when it is set equal to zero. Therefore, we need to set  $(z + 1)^2$  equal to  $0$ :

$$(z + 1)^2 = 0$$

$$z + 1 = 0$$

$$z = -1$$

The minimum possible value for  $x$  occurs when  $z = -1$ , and  $x \geq 4 + (-1 + 1)^2 = 4 + 0 = 4$ . Therefore  $x \geq 4$ , so  $4$  is the minimum possible value for  $x$ .

**Check Your Skills**

28. If  $-1 \leq a \leq 4$  and  $-6 \leq b \leq -2$ , what is the minimum value for  $b - a$ ?
29. If  $(x + 2)^2 \leq 2 - y$ , what is the maximum possible value for  $y$ ?

*Answers can be found on page 97.*

## Summary of Inequality Techniques

We have covered many topics in inequalities. Here is a quick recap of “DOs and DON’Ts” when working with inequalities:

DOs	DON’Ts
<ul style="list-style-type: none"> <li>• DO think about inequalities as ranges on a number line.</li> <li>• DO treat inequalities like equations when adding or subtracting terms, or when multiplying/dividing by a positive number on both sides of the inequality.</li> <li>• DO use extreme values to solve inequality range problems, problems containing both inequalities and equations, and many optimization problems.</li> <li>• DO set terms with even exponents equal to zero when trying to solve minimization problems.</li> </ul>	<ul style="list-style-type: none"> <li>• DON’T forget to flip the inequality sign if you multiply or divide both sides of an inequality by a negative number.</li> <li>• DON’T multiply or divide an inequality by a variable unless you know the sign of the variable.</li> <li>• DON’T forget to perform operations on every expression when manipulating a compound inequality.</li> </ul>

## Check Your Skills Answer Key:

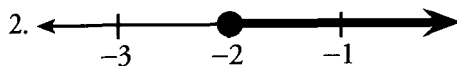
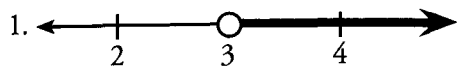

4.  $z > v$

5. Let  $a$  = amount.  
 $a > \$2,000$

6. A, B, C, D: All of these numbers are to the left of 10 on the number line.

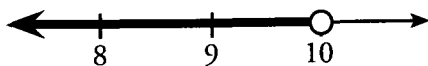

7.  $x - 6 < 13$   
 $x < 19$

8.  $y + 11 \geq -13$   
 $y \geq -24$

9.  $x + 7 > 7$   
 $x > 0$

10.  $x + 3 \geq -2$   
 $x \geq -5$

11.  $-2y < 8$   
 $y > -4$

12.  $a + 4 \geq 2a$   
 $4 \geq a$

13. True

14. False — (Note that absolute value is always positive!)

15. False

16. True

17. True ( $|3 - 6| = |-3| = 3$ )

18. False

19.  $|a| = 6$

$a = 6$  or  $a = -6$

20.  $x = 3$  or  $-7$ :  $|x + 2| = 5$

$+$	$(x + 2) = 5$	or	$-(x + 2) = 5$
	$x + 2 = 5$	or	$-x - 2 = 5$
	$x = 3$	or	$-x = 7$
			$x = -7$

21.  $y = 7$  or  $-13/3$ :  $|3y - 4| = 17$

$+$	$(3y - 4) = 17$	or	$-(3y - 4) = 17$
	$3y - 4 = 17$	or	$-3y + 4 = 17$
	$3y = 21$	or	$-3y = 13$
	$y = 7$	or	$y = -13/3$

22.  $x = 4$  or  $-5$ :  $4|x + 1/2| = 18$

$+$	$(x + 1/2) = 4 \frac{1}{2}$	or	$-(x + 1/2) = 4 \frac{1}{2}$
	$x + 1/2 = 4 \frac{1}{2}$	or	$-x - 1/2 = 4 \frac{1}{2}$
	$x = 4$	or	$-x = 5$
			$x = -5$

23.  $|x + 1| > 2$

$+$	$(x + 1) > 2$	or	$-(x + 1) > 2$
	$x + 1 > 2$	or	$-x - 1 > 2$
	$x > 1$	or	$-x > 3$
			$x < -3$

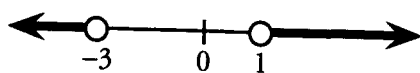

$x < -3$  OR  $x > 1$

24.  $|-x - 4| \geq 8$

$+$	$(-x - 4) \geq 8$	or	$-(-x - 4) \geq 8$
	$-x - 4 \geq 8$	or	$x + 4 \geq 8$
	$-x \geq 12$	or	$x \geq 4$
	$x \leq -12$		

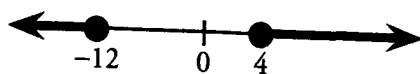

$x \leq -12$  OR  $x \geq 4$

25.  $|x - 7| < 9$

$+$	$(x - 7) < 9$	or	$-(x - 7) < 9$
	$x - 7 < 9$	or	$-x + 7 < 9$
	$x < 16$	or	$-x < 2$
			$x > -2$

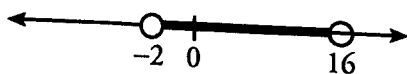

$x > -2$  AND  $x < 16$ ,  $-2 < x < 16$

26.  $-3 < x < 5$ ;  $-7 < 3 - 2x < 9$

$-10 < -2x < 6$

$5 > x > -3$

or  $-3 < x < 5$

Subtract 3 from all three terms.

Divide all three terms by  $-2$ , and flip the inequality signs.

27. **E:** Extreme Values for  $a$  are greater than  $-4$ , or  $GT(-4)$ , and less than  $4$ , or  $LT(4)$ .

Extreme values for  $b$  are greater than  $-2$ , or  $GT(-2)$ , and less than  $-1$ , or  $LT(-1)$ .

$a$  can be positive or negative, while  $b$  can only be negative, so  $ab$  can be positive and negative.

The most negative  $ab$  can be is  $GT(-2) \times GT(4) = GT(-8)$ .

The most positive  $ab$  can be is  $GT(-4) \times GT(-2) = LT(+8)$ .

28. **-10:**

$a$	$b$	$b - a$
-1	-6	$-6 - (-1) = -5$
-1	-2	$-2 - (-1) = -1$
4	-6	$-6 - 4 = -10$
4	-2	$-2 - 4 = -6$

29. **2:**  $(x + 2)^2 \leq 2 - y$

$y + (x + 2)^2 \leq 2$

$y \leq 2 - (x + 2)^2$

Add  $y$  to both sides

Subtract  $(x + 2)^2$  from both sides

$y$  is maximized when  $(x + 2)^2$  is minimized. The smallest possible value for  $(x + 2)^2$  is 0, when  $x = -2$ . When

$(x + 2)^2 = 0$ ,  $y = 2$ .

**Problem Set**

1. If  $4x - 12 \geq x + 9$ , which of the following must be true?  
 (A)  $x > 6$       (B)  $x < 7$       (C)  $x > 7$       (D)  $x > 8$       (E)  $x < 8$
2. Which of the following is equivalent to  $-3x + 7 \leq 2x + 32$ ?  
 (A)  $x \geq -5$       (B)  $x \geq 5$       (C)  $x \leq 5$       (D)  $x \leq -5$
3. If  $G^2 < G$ , which of the following could be  $G$ ?  
 (A) 1      (B)  $\frac{23}{7}$       (C)  $\frac{7}{23}$       (D) -4      (E) -2
4. If  $|A| > 19$ , which of the following could not be equal to  $A$ ?  
 (A) 26      (B) 22      (C) 18      (D) -20      (E) -24
5. If  $B^3A < 0$  and  $A > 0$ , which of the following must be negative?  
 (A)  $AB$       (B)  $B^2A$       (C)  $B^4$       (D)  $\frac{A}{B^2}$       (E)  $-\frac{B}{A}$

6.  $|2x - 5| \leq 7$

<u>Quantity A</u>		<u>Quantity B</u>
$x$		3

7.  $1 \leq x \leq 5$  and  $1 \geq y \geq -2$

<u>Quantity A</u>		<u>Quantity B</u>
$xy$		-10

8.  $x = 4$

<u>Quantity A</u>		<u>Quantity B</u>
$ 2 - x $		2

1. **A:**  $4x - 12 \geq x + 9$   
 $3x \geq 21$   
 $x \geq 7$

If  $x \geq 7$ , then  $x > 6$ .

2. **A:**  $-3x + 7 \leq 2x + 32$  When you divide by a negative number, you must  
 $-5x \leq 25$  reverse the direction of the inequality symbol.  
 $x \geq -5$

3. **C:** If  $G^2 < G$ , then  $G$  must be positive (since  $G^2$  will never be negative), and  $G$  must be less than 1, because otherwise,  $G^2 > G$ . Thus,  $0 < G < 1$ . We can eliminate Choices D and E, since they violate the condition that  $G$  be positive. Then test Choice A: 1 is not less than 1, so we can eliminate A. Choice B is larger than 1, so only Choice C satisfies the inequality.

4. **C:** If  $|A| > 19$ , then  $A > 19$  OR  $A < -19$ . The only answer choice that does not satisfy either of these inequalities is Choice C, 18.

5. **A:** If  $A$  is positive,  $B^3$  must be negative. Therefore,  $B$  must be negative. If  $A$  is positive and  $B$  is negative, the product  $AB$  must be negative.

6. **D:** To evaluate the absolute value, set up two equations and isolate  $x$ .

$+(2x - 5) \leq 7$	AND	$-(2x - 5) \leq 7$
$2x - 5 \leq 7$		$-2x + 5 \leq 7$
$2x \leq 12$		$-2x \leq 2$
$x \leq 6$		$x \geq -1$

Combine the information from the two equations.

$$|2x - 5| \leq 7$$

**Quantity A**

$$-1 \leq x \leq 6$$

**Quantity B**

$$3$$

There are possible values of  $x$  greater than AND less than 3. **We do not have enough information.**

7. **D:** To find the minimum and maximum values of  $xy$ , test the boundaries of  $x$  and  $y$ .

$x$	$y$	$xy$
Min 1	Min -2	$(1) \times (-2) = -2$
Min 1	Max 1	$(1) \times (1) = 1$
Max 5	Min -2	$(5) \times (-2) = -10$
Max 5	Max 1	$(5) \times (1) = 5$

Combine the information from the chart to show the range of  $xy$ .

$$1 \leq x \leq 5 \text{ and } 1 \geq y \geq -2$$

**Quantity A**

$$-10 \leq xy \leq 5$$

**Quantity B**

$$-10$$

Quantity A can be either greater than or equal to  $-10$ . **We do not have enough information.**

8. C: Plug in 4 for  $x$  in Quantity A.

$$x = 4$$

**Quantity A**

$$|2 - x| =$$

$$|2 - (4)| = |-2| = 2$$

**Quantity B**

$$2$$

**The two quantities are equal.**



g

**Chapter 5**  
*of*

ALGEBRA

**FORMULAS &  
FUNCTIONS**

## In This Chapter . . .

---

# S

- Plug In Formulas
- Strange Symbol Formulas
- Formulas with Unspecified Amounts
- Sequence Formulas: Direct and Recursive
- Sequence Problems
- Sequences and Patterns

## Plug-In Formulas

The most basic GRE formula problems provide you with a formula and ask you to solve for one of the variables in the formula by plugging in given values for the other variables. For example:

The formula for determining an individual's comedic aptitude,  $C$ , on a given day is defined as  $\frac{QL}{J}$ , where  $J$  represents the number of jokes told,  $Q$  represents the overall joke quality on a scale of 1 to 10, and  $L$  represents the number of individual laughs generated. If Nicole told 12 jokes, generated 18 laughs, and earned a comedic aptitude of 10.5, what was the overall quality of her jokes?

Solving this problem simply involves plugging the given values into the formula in order to solve for the unknown variable  $Q$ :

$$C = \frac{QL}{J} \rightarrow 10.5 = \frac{18Q}{12} \rightarrow 10.5(12) = 18Q \rightarrow Q = \frac{10.5(12)}{18} \rightarrow Q = 7$$



The quality of Nicole's jokes was rated a 7.

Notice that you will typically have to do some rearrangement after plugging in the numbers, in order to isolate the desired unknown. The actual computations are not complex. What makes Formula problems tricky is the unfamiliarity of the given formula, which may seem to come from "out of the blue." Do not be intimidated. Simply write the equation down, plug in the numbers carefully, and solve for the required unknown.

Be sure to write the formula as a part of an equation. For instance, do not just write " $\frac{QL}{J}$ " on your paper. Rather, write " $C = \frac{QL}{J}$ ." Look for language such as "is defined as" to identify what equals what.

### Check Your Skills

1. For a certain cake, the baking time in minutes is defined as  $\frac{Vk}{T}$ , where  $V$  is the volume of the cake in inches<sup>3</sup>,  $T$  is the oven temperature in degrees Fahrenheit, and  $k$  is a constant. If the baking time was 30 minutes at 350 degrees Fahrenheit for a 150 inches<sup>3</sup> cake, what is the value of constant  $k$ ?

*Answer can be found on page 115.*

## Strange Symbol Formulas

Another type of GRE formula problem involves the use of strange symbols. In these problems, the GRE introduces an arbitrary symbol, which defines a certain procedure. These problems may look confusing because of the unfamiliar symbols. However, the symbol is IRRELEVANT. All that is important is that you carefully follow each step in the procedure that the symbol indicates.

A technique that can be helpful is to break the operations down one by one and say them aloud (or in your head)—to "hear" them explicitly. Here are some examples:

FORMULA DEFINITION

$$x \heartsuit y = x^2 + y^2 - xy$$

$$s \circ t = (s - 2)(t + 2)$$

$\boxed{x}$  is defined as the product of all integers smaller than  $x$  but greater than 0...

STEP-BY-STEP BREAKDOWN

“The first number squared, plus the second number squared, minus the product of the two...”

“Two less than the first number times two more than the second number...”

“... $x$  minus 1, times  $x$  minus 2, times  $x$  minus 3...  
Aha! So this is  $(x - 1)$  factorial!”

Notice that it can be helpful to refer to the variables as “the first number,” “the second number,” and so on. In this way, you use the physical position of the numbers to keep them straight in relation to the strange symbol.

Now that you have interpreted the formula step-by-step and can understand what it means, you can calculate a solution for the formula with actual numbers. Consider the following example:

$$W \Psi F = (\sqrt{W})^F \text{ for all integers } W \text{ and } F. \text{ What is } 4 \Psi 3? ?$$

The symbol  $\Psi$  between two numbers signals the following procedure: take the square root of the FIRST number and then raise that value to the power of the SECOND number.

$$4 \Psi 3 = (\sqrt{4})^3 = 2^3 = 8.$$

Watch out for symbols that INVERT the order of an operation. It is easy to automatically translate the function in a “left to right” manner even when that is NOT what the function specifies.

$$W \Phi F = (\sqrt{F})^W \text{ for all integers } W \text{ and } F. \text{ What is } 4 \Phi 9?$$

It would be easy in this example to mistakenly calculate the formula in the same way as the first example. However notice that the order of the operation is REVERSED—we need to take the square root of the SECOND number, raised to the power of the FIRST number:

$$4 \Phi 9 = (\sqrt{9})^4 = 3^4 = 81.$$

More challenging strange-symbol problems require you to use the given procedure more than once. For example:

$$A \Phi B = (\sqrt{B})^A \text{ for all integers } A \text{ and } B. \text{ What is } 2 \Phi (3 \Phi 16)?$$

Always perform the procedure inside the parentheses FIRST:

$$3 \Phi 16 = (\sqrt{16})^3 = 4^3 = 64.$$

Now we can rewrite the original formula as follows:  $2 \Phi (3 \Phi 16) = 2 \Phi 64$ .

Performing the procedure a second time yields the answer:

$$2 \Phi 64 = (\sqrt{64})^2 = 8^2 = 64.$$

**Check Your Skills**

2.  $A\Delta B = A^B + B$  for all integers  $A$  and  $B$ . What is the value of  $-2\Delta(3\Delta 1)$ ?

3.  $s\lambda t = \frac{t}{s} + \frac{s}{t}$  for all integers  $s$  and  $t$ . What is the value of  $2\lambda 16$ ?

*Answers can be found on page 115.*

**Formulas with Unspecified Amounts**

Some of the most challenging formula problems on the GRE are those that involve unspecified amounts. Typically, these questions focus on the increase or decrease in the value of a certain formula, given a change in the value of the variables. Just as with other GRE problems with unspecified amounts, solve these problems by PICKING NUMBERS!

If the length of the side of a cube decreases by two-thirds its original value, by what percentage will the volume of the cube decrease?

First, consider the formula involved here. The volume of a cube is defined by the formula  $V = s^3$ , where  $s$  represents the length of a side. Then, pick a number for the length of the side of the cube.

Let us say the cube has a side of 3 units. Note that this is a “smart” number to pick because it is divisible by 3 (the denominator of two-thirds).

Then, its volume  $= s^3 = 3 \times 3 \times 3 = 27$ .

If the cube's side decreases by two-thirds, its new length is  $3 - \frac{2}{3}(3) = 1$  unit.

Its new volume  $= s^3 = 1 \times 1 \times 1 = 1$ .

We determine percentage decrease as follows:

$$\frac{\text{change}}{\text{original}} = \frac{27 - 1}{27} = \frac{26}{27} \approx 0.963 = 96.3\% \text{ decrease.}$$

**Check Your Skills**

4. When Tom moved to a new home, his distance to work decreased by  $1/2$  the original distance and the constant rate at which he travels to work increased by  $1/3$  the original rate. By what percent has the time it takes Tom to travel to work decreased?

*Answer can be found on page 115.*

## Sequence Formulas: Direct and Recursive

The final type of GRE formula problem involves sequences. A sequence is a collection of numbers in a set order. The order of a given sequence is determined by a RULE. Here are examples of sequence RULES:

$$A_n = 9n + 3$$

The  $n$ th term of this sequence is defined by the rule  $9n + 3$ , for integers  $n \geq 1$ . For example, the fourth term in this sequence is  $9n + 3 = 9(4) + 3 = 39$ . The first ten terms of the sequence are as follows:  
12, 21, 30, 39, 48, 57, 66, 75, 84, 93  
(notice that successive terms differ by 9)

$$Q_n = n^2 + 4$$

The  $n$ th term of this sequence is defined by the rule  $n^2 + 4$ , for integers  $n \geq 1$ . For example, the first term in this sequence is  $1^2 + 4 = 5$ . The first ten terms of the sequence are as follows:  
5, 8, 13, 20, 29, 40, 53, 68, 85, 104

In the above cases, each item of the sequence is defined as a function of  $n$ , the place in which the term occurs in the sequence. For example, the value of  $A_5$  is a function of its being the 5th item in the sequence. This is a **direct** definition of a sequence formula.

The GRE also uses **recursive** formulas to define sequences. With direct formulas, the value of each item in a sequence is defined in terms of its item number in the sequence. With recursive formulas, each item of a sequence is defined in terms of the value of PREVIOUS ITEMS in the sequence.

A recursive formula looks like this:  $A_n = A_{n-1} + 9$

This formula simply means “THIS term ( $A_n$ ) equals the PREVIOUS term ( $A_{n-1}$ ) plus 9.” It is shorthand for a series of specific relationships between successive terms:

$$\begin{aligned} A_2 &= A_1 + 9 \\ A_3 &= A_2 + 9 \\ A_4 &= A_3 + 9, \text{ etc.} \end{aligned}$$

Whenever you look at a recursive formula, articulate its meaning in words in your mind. If necessary, also write out one or two specific relationships that the recursive formula stands for. Think of a recursive formula as a “domino” relationship: if you know  $A_1$ , then you can find  $A_2$ , and then you can find  $A_3$ , then  $A_4$ , and so on for all the terms. You can also work backward: if you know  $A_4$ , then you can find  $A_3$ ,  $A_2$ , and  $A_1$ . However, if you do not know the value of any one term, then you cannot calculate the value of any other. You need one domino to fall, so to speak, in order to knock down all the others.

Thus, to solve for the values of a recursive sequence, you need to be given the recursive rule and ALSO the value of one of the items in the sequence. For example:

$$\begin{aligned} A_n &= A_{n-1} + 9 \\ A_1 &= 12 \end{aligned}$$

In this example,  $A_n$  is defined in terms of the previous item,  $A_{n-1}$ . Recall the meaning of this recursive formula: THIS term equals the PREVIOUS term plus 9. Because  $A_1 = 12$ , we can determine that  $A_2 = A_1 + 9 = 12 + 9 = 21$ . Therefore,  $A_3 = 21 + 9 = 30$ ,  $A_4 = 30 + 9 = 39$ , and so on.

Because the first term is 12, this sequence is identical to the sequence defined by the direct definition,  $A_n = 9n + 3$ , given at the top of this page. Here is another example:

$$F_n = F_{n-1} + F_{n-2}$$

$$F_1 = 1, F_2 = 1$$

In this example,  $F_n$  is defined in terms of BOTH the previous item,  $F_{n-1}$ , and the item prior to that,  $F_{n-2}$ . This recursive formula means "THIS term equals the PREVIOUS term plus the term BEFORE THAT." Because  $F_1 = 1$  and  $F_2 = 1$ , we can determine that  $F_3 = F_1 + F_2 = 1 + 1 = 2$ . Therefore  $F_4 = 2 + 1 = 3$ ,  $F_5 = 3 + 2 = 5$ ,  $F_6 = 5 + 3 = 8$ , and so on. There is no simple direct rule for this sequence.

### Check Your Skills

- $S_n = 2n - 5$  for all integers  $n \geq 1$ . What is the 11th term of the sequence?
- $B_n = (-1)^n \times n + 3$  for all integers  $n \geq 1$ . What is the 9th term of the sequence?
- If  $A_n = 2A_{n-1} + 3$  for all  $n \geq 1$ , and  $A_4 = 45$ , what is  $A_1$ ?

*Answers can be found on page 115.*

### Sequence Problems

For sequence problems on the GRE, you may be asked to do any of the following:

- Determine which answer choice corresponds to the correct definition (or rule) for a sequence (direct or recursive)
- Determine the value of a particular item in a sequence
- Determine the sum or difference of a set of items in a sequence

For simple linear sequences, in which the same number is added to any term to yield the next term, we can use the following alternative method—rather than find the RULE or definition for the sequence, we can sometimes logically derive one item in the sequence based on the information given:

If each number in a sequence is three more than the previous number, and the sixth number is 32, what is the 100th number?

Instead of finding the rule for this sequence, consider the following reasoning:

From the sixth term to the one hundredth term, there are 94 "jumps" of 3. Since  $94 \times 3 = 282$ , there is an increase of 282 from the sixth term to the one hundredth term:

$$32 + 282 = 314.$$

### Check Your Skills

- If each number of a sequence is 4 more than the previous number, and the 3rd number in the sequence is 13, what is the 114th number in the sequence?

*Answers can be found on page 115.*

## Sequences and Patterns

As we have discussed, sequence problems generally involve finding patterns among the *items in a sequence*, or the *definition/rule for the sequence*. Generally, for questions involving the sequence *items themselves*, the best approach involves writing down information (often in the form of an equation) for *specific items* in the sequence, and trying to find a *pattern* among these items.

If  $S_n = 3^n$ , what is the units digit of  $S_{65}$ ?

Clearly, you cannot be expected to multiply out  $3^{65}$  on the GRE, even with a calculator. Therefore, you must look for a pattern in the powers of three.

$$\begin{aligned} 3^1 &= 3 \\ 3^2 &= 9 \\ 3^3 &= 27 \\ 3^4 &= 81 \\ 3^5 &= 243 \\ 3^6 &= 729 \\ 3^7 &= 2,187 \\ 3^8 &= 6,561 \end{aligned}$$

You can see that the units digits of powers of 3 follow the pattern “3, 9, 7, 1” before repeating. The units digit of  $3^{65}$  will thus be 3, because the 64th term will be “1” as 64 is divisible by 4 (and the pattern repeats every four terms).

As a side note, most sequences on the GRE are defined for integers  $n \geq 1$ . That is, sequence  $S_n$  almost always starts at  $S_1$ . Occasionally, a sequence might start at  $S_0$ , but in that case, you will be told that  $n$  could equal 0.

### Check Your Skills

9. If  $A_n = 7^n - 1$ , what is the units digit of  $A_{33}$ ?

*Answer can be found on pages 115–116.*

## Functions

Functions are very much like the “magic boxes” you may have learned about in elementary school.

You put a 2 into the magic box, and a 7 comes out. You put a 3 into the magic box, and a 9 comes out. You put a 4 into the magic box, and an 11 comes out. What is the magic box doing to your number?

There are many possible ways to describe what the magic box is doing to your number. One possibility is as follows: The magic box is doubling your number and adding 3.

$$2(2) + 3 = 7$$

$$2(3) + 3 = 9$$

$$2(4) + 3 = 11$$

Assuming that this is the case (it is possible that the magic box is actually doing something different to your number), this description would yield the following “rule” for this magic box:  $2x + 3$ . This rule can be written in function form as:

$$f(x) = 2x + 3.$$



The function  $f$  represents the “rule” that the magic box is using to transform your number. Again, this rule may or may not be the “true” rule for the magic box. That is, if we put more numbers into the box and watch what numbers emerge, this rule may or may not hold. It is never possible to generalize a rule only by using specific cases.

Nevertheless, the magic box analogy is a helpful way to conceptualize a function as a RULE built on an independent variable. The value of a function changes as the value of the independent variable changes. In other words, the value of a function is dependent on the value of the independent variable. Examples of functions include:

$$f(x) = 4x^2 - 11$$

The value of the function,  $f$ , is dependent on the independent variable,  $x$ .

$$g(t) = t^3 + \sqrt{t} - \frac{2t}{5}$$

The value of the function,  $g$ , is dependent on the independent variable,  $t$ .

We can think of functions as consisting of an “input” variable (the number you put into the magic box), and a corresponding “output” value (the number that comes out of the box). The function is simply the rule that turns the “input” variable into the “output” variable.

By the way, the expression  $f(x)$  is pronounced “ $f$  of  $x$ ”, not “ $fx$ .” It does NOT mean “ $f$  TIMES  $x$ ”! The letter  $f$  does NOT stand for a variable; rather, it stands for the rule that dictates how the input  $x$  changes into the output  $f(x)$ .

The “domain” of a function indicates the possible inputs. The “range” of a function indicates the possible outputs. For instance, the function  $f(x) = x^2$  can take any input but never produces a negative number. So the domain is all numbers, but the range is  $f(x) \geq 0$ .

### Numerical Substitution

This is the most basic type of function problem. Input the numerical value (say, 5) in place of the independent variable ( $x$ ) to determine the value of the function.

If  $f(x) = x^2 - 2$ , what is the value of  $f(5)$ ?

In this problem, you are given a rule for  $f(x)$ : square  $x$  and subtract 2. Then, you are asked to apply this rule to the number 5. Square 5 and subtract 2 from the result:

$$f(5) = (5)^2 - 2 = 25 - 2 = 23$$

### Variable Substitution

This type of problem is slightly more complicated. Instead of finding the output value for a numerical input, you must find the output when the input is an algebraic expression.

If  $f(z) = z^2 - \frac{z}{3}$ , what is the value of  $f(w + 6)$ ?

Input the variable expression  $(w + 6)$  in place of the independent variable ( $z$ ) to determine the value of the function:

$$f(w + 6) = (w + 6)^2 - \frac{w + 6}{3}$$

Compare this equation to the equation for  $f(z)$ . The expression  $(w + 6)$  has taken the place of every  $z$  in the original equation. In a sense, you are treating the expression  $(w + 6)$  as one thing, as if it were a single letter or variable.

The rest is algebraic simplification:

$$\begin{aligned} f(w + 6) &= (w + 6)(w + 6) - \left(\frac{w}{3} + \frac{6}{3}\right) \\ &= w^2 + 12w + 36 - \frac{w}{3} - 2 \\ &= w^2 + 11\frac{2}{3}w + 34 \end{aligned}$$

### Compound Functions

Imagine putting a number into one magic box, and then putting the output directly into another magic box. This is the situation you have with compound functions.

$$\text{If } f(x) = x^3 + \sqrt{x} \text{ and } g(x) = 4x - 3, \text{ what is } f(g(3))?$$

The expression  $f(g(3))$ , pronounced “ $f$  of  $g$  of 3”, looks ugly, but the key to solving compound function problems is to work from the **INSIDE OUT**. In this case, start with  $g(3)$ . Notice that we put the number into  $g$ , not into  $f$ , which may seem backward at first.

$$g(3) = 4(3) - 3 = 12 - 3 = 9$$

Use the result from the inner function  $g$  as the new input variable for the outer function  $f$ :

$$f(g(3)) = f(9) = (9)^3 + \sqrt{9} = 729 + 3 = 732 \quad \text{The final result is 732.}$$

Note that changing the order of the compound functions changes the answer:

$$\text{If } f(x) = x^3 + \sqrt{x} \text{ and } g(x) = 4x - 3, \text{ what is } g(f(3))?$$

Again, work from the inside out. This time, start with  $f(3)$  [which is now the inner function]:

$$f(3) = (3)^3 + \sqrt{3} = 27 + \sqrt{3}$$

Use the result from the inner function  $f$  as the new input variable for the outer function  $g$ :

$$g(f(3)) = g(27 + \sqrt{3}) = 4(27 + \sqrt{3}) - 3 = 108 + 4\sqrt{3} - 3 = 105 + 4\sqrt{3}$$

$$\text{Thus, } g(f(3)) = 105 + 4\sqrt{3}.$$

In general,  $f(g(x))$  and  $g(f(x))$  are **not the same rule overall** and will often lead to different outcomes. As an analogy, think of “putting on socks” and “putting on shoes” as two functions: the order in which you perform these steps obviously matters!

You may be asked to **find** a value of  $x$  for which  $f(g(x)) = g(f(x))$ . In that case, use **variable substitution**, working as always from the inside out:

If  $f(x) = x^3 + 1$ , and  $g(x) = 2x$ , for what value of  $x$  does  $f(g(x)) = g(f(x))$ ?

Simply evaluate as we did in the problems above, using  $x$  instead of an input value:

$$\begin{array}{l} f(g(x)) = g(f(x)) \\ f(2x) = g(x^3 + 1) \\ (2x)^3 + 1 = 2(x^3 + 1) \end{array} \quad \begin{array}{l} \nearrow \\ \\ \end{array} \quad \begin{array}{l} 8x^3 + 1 = 2x^3 + 2 \\ 6x^3 = 1 \\ x = \sqrt[3]{\frac{1}{6}} \end{array}$$

### **Functions with Unknown Constants**

On the GRE, you may be given a function with an unknown constant. You will also be given the value of the function for a specific number. You can combine these pieces of information to find the complete function rule.

If  $f(x) = ax^2 - x$ , and  $f(4) = 28$ , what is  $f(-2)$ ?

Solve these problems in three steps. **FIRST**, use the value of the input variable and the corresponding output value of the function to solve for the unknown constant:

$$\begin{aligned} f(4) &= a(4)^2 - 4 = 28 \\ 16a - 4 &= 28 \\ 16a &= 32 \\ a &= 2 \end{aligned}$$

**THEN**, rewrite the function, replacing the constant with its numerical value:

$$f(x) = ax^2 - x = 2x^2 - x$$

**FINALLY**, solve the function for the new input variable:

$$f(-2) = 2(-2)^2 - (-2) = 8 + 2 = 10$$

There are 8 repeats of the pattern from  $A_1$  to  $A_{32}$ , inclusive. The pattern begins again on  $A_{33}$ , so  $A_{33}$  has the same units digit as  $A_1$ , which is 7. The units digit of  $7^{33}$  is 7, and  $7 - 1 = 6$ .

10. 5: Simply plug in  $(-1)$  for each occurrence of  $x$  in the function definition and evaluate:

$$f(x) = \frac{1}{x+2} + (x-1)^2 \quad f(-1) = \frac{1}{(-1)+2} + ((-1)-1)^2$$

$$f(1) = \frac{1}{1} + (-2)^2 = 1 + 4 = 5$$

11. 5: Plug 3 in for  $u$  in the definition of  $t(u)$ , set it equal to 37, and solve for  $a$ .

$$t(u) = au^2 - 3u + 1 \rightarrow t(3) = a(3)^2 - 3(3) + 1 = 37$$

$$9a - 9 + 1 = 37$$

$$9a = 45$$

$$a = 5$$

12. 100: First, find the output value of the inner function:  $f(4) = 3(4) - \sqrt{4} = 12 - 2 = 10$ .

Then, find  $g(10)$ :  $10^2 = 100$ .

13.  $\frac{-x^3 + x + 1}{x^3 + x^2}$ : Simply plug  $\left(\frac{1}{x}\right)$  in for  $y$  in  $g(y)$ , and simplify the expression:

$$g(y) = y^2 - \frac{1}{y+1} \rightarrow g\left(\frac{1}{x}\right) = \left(\frac{1}{x}\right)^2 - \frac{1}{\left(\frac{1}{x}\right)+1}$$

$$g\left(\frac{1}{x}\right) = \frac{1}{x^2} - \frac{1}{\frac{x+1}{x}} = \frac{1}{x^2} - \frac{x}{x+1}$$

$$g\left(\frac{1}{x}\right) = \frac{x+1-x^3}{x^2(x+1)} = \frac{-x^3 + x + 1}{x^3 + x^2}$$

## Problem Set

1. Given that  $A \diamond B = 4A - B$ , what is the value of  $(3 \diamond 2) \diamond 3$ ?

2. Given that  $\begin{array}{c} x \\ u \quad y \\ z \end{array} = \frac{u+y}{x+z}$ , what is  $\begin{array}{c} 4 \\ 8 \quad 10 \\ 5 \end{array}$  ?

3. Life expectancy is defined by the formula  $\frac{2SB}{G}$ , where  $S$  = shoe size,  $B$  = average monthly electric bill in dollars, and  $G$  = GRE score. If Melvin's GRE score is twice his monthly electric bill, and his life expectancy is 50, what is his shoe size?

4. The formula for spring factor in a shoe insole is  $\frac{w^2+x}{3}$ , where  $w$  is the width of the insole in centimeters and  $x$  is the grade of rubber on a scale of 1 to 9. What is the maximum spring factor for an insole that is 3 centimeters wide?

5. Cost is expressed by the formula  $tb^4$ . If  $b$  is doubled, by what factor has the cost increased?  
(A) 2 (B) 6 (C) 8 (D) 16 (E)  $1/2$

6. If the scale model of a cube sculpture is 0.5 cm per every 1 m of the real sculpture, what is the volume of the model, if the volume of the real sculpture is  $64 \text{ m}^3$ ?

7. The "competitive edge" of a baseball team is defined by the formula  $\sqrt{\frac{W}{L}}$ , where  $W$  represents the number of wins, and  $L$  represents the number of losses. This year, the GRE All-Stars had 3 times as many wins and one-half as many losses as they had last year. By what factor did their "competitive edge" increase?

8. If the radius of a circle is tripled, what is the ratio of the area of half the original circle to the area of the whole new circle? (Area of a circle =  $\pi r^2$ , where  $r$  = radius)

For problems #9–10, use the following sequence definition:  $A_n = 3 - 8n$ .

9. What is  $A_1$ ?

10. What is  $A_{11} - A_9$ ?

11. A sequence  $S$  is defined as follows:  $S_n = \frac{S_{n+1} + S_{n-1}}{2}$ . If  $S_1 = 15$  and  $S_4 = 10.5$ , what is  $S_2$ ?

12. If  $f(x) = 2x^4 - x^2$ , what is the value of  $f(2\sqrt{3})$ ?

13. If  $k(x) = 4x^3a$ , and  $k(3) = 27$ , what is  $k(2)$ ?

14. If  $f(x) = 3x - \sqrt{x}$  and  $g(x) = x^2$ , what is  $f(g(4))$ ?

15. If  $f(x) = 2x^2 - 4$  and  $g(x) = 2x$ , for what values of  $x$  will  $f(x) = g(x)$ ?

16. Which of the following graphs is the graph of Function  $g(x) = |x - 1| - 1$ ?

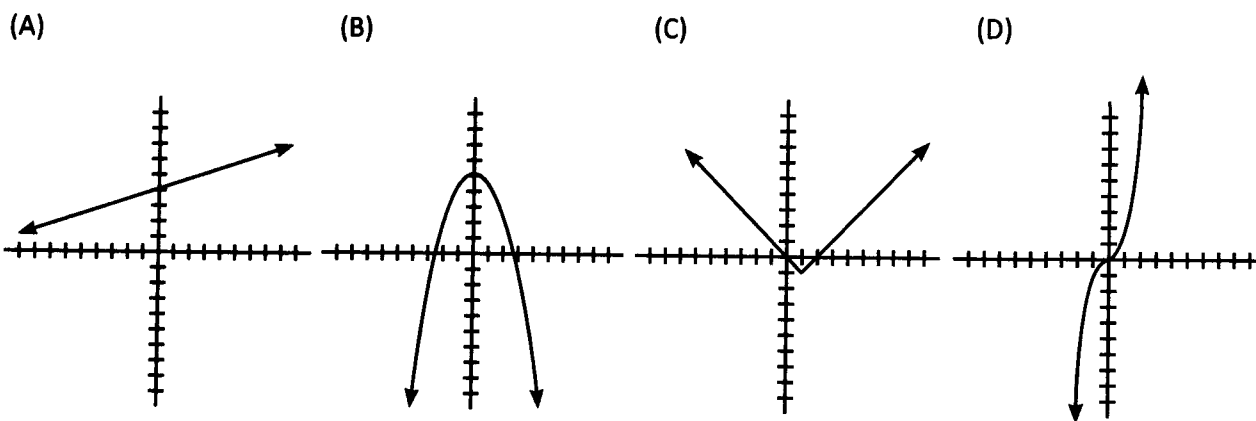

17.

$$A_n = 2^n - 1 \text{ for all integers } n \geq 1$$

**Quantity A**

The units digit of  $A_{26}$

**Quantity B**

The units digit of  $A_{34}$

18.

$$P \blacksquare Q = P + 2Q \text{ for all integers } P \text{ and } Q.$$

**Quantity A**

$$11 \blacksquare 5$$

**Quantity B**

$$5 \blacksquare 11$$

19.

The length of a rectangle increased by a factor of 2, and at the same time its area increased by a factor of 6.

**Quantity A**

The factor by which the width of the rectangle increased

**Quantity B**

3

1. **37:** First, simplify  $3 \diamond 2$ :  $4(3) - 2 = 12 - 2 = 10$ . Then, solve  $10 \diamond 3$ :  $4(10) - 3 = 40 - 3 = 37$ .

2. **2:** Plug the numbers in the grid into the formula, matching up the number in each section with the corresponding

variable in the formula  $\frac{u+y}{x+z} = \frac{8+10}{4+5} = \frac{18}{9} = 2$ .

3. **Size 50:**

$$\frac{2SB}{2B} = 50$$

Substitute  $2B$  for  $G$  in the formula. Note that the term  $2B$  appears in both the numerator and denominator, so they cancel out.

$$S = 50$$

4. **6:** Determine the maximum spring factor by setting  $x = 9$ .

Let  $s$  = spring factor

$$s = \frac{w^2 + x}{3} \qquad s = \frac{(3)^2 + 9}{3} = \frac{18}{3} = 6$$

5. **D:** Pick numbers to see what happens to the cost when  $b$  is doubled. If the original value of  $b$  is 2, the cost is  $16t$ . When  $b$  is doubled to 4, the new cost value is  $256t$ . The cost has increased

by a factor of  $\frac{256}{16}$ , or 16.

6. **8 cm<sup>3</sup>:**

$$V = s^3 \rightarrow 64 = s^3 \rightarrow s = 4 \quad \text{The length of a side on the real sculpture is 4 m.}$$

$$\frac{0.5 \text{ cm}}{1 \text{ m}} = \frac{x \text{ cm}}{4 \text{ m}} \rightarrow x = 2 \quad \text{The length of a side on the model is 2 cm.}$$

$$V = s^3 = (2)^3 = 8 \quad \text{The volume of the model is 8.}$$

7.  **$\sqrt{6}$ :**

Let  $c$  = competitive edge

$$c = \sqrt{\frac{W}{L}}$$

Pick numbers to see what happens to the competitive edge when  $W$  is tripled and  $L$  is halved. If the original value of  $W$  is 2 and the original value of  $L$  is 4, the original value of  $c$  is

$$\sqrt{\frac{2}{4}} = \sqrt{\frac{1}{2}} = \frac{1}{\sqrt{2}} = \frac{\sqrt{2}}{2}. \text{ If } W \text{ triples to 6 and } L \text{ is halved to 2, the new value of } c \text{ is } \sqrt{\frac{6}{2}} = \sqrt{3}.$$

The competitive edge has increased from  $\frac{\sqrt{2}}{2}$  to  $\sqrt{3}$ .

$$\frac{\sqrt{2}}{2}x = \sqrt{3} \qquad x = \sqrt{3} \left( \frac{2}{\sqrt{2}} \right) = \frac{2\sqrt{3}}{\sqrt{2}} = \frac{2\sqrt{3}(\sqrt{2})}{2} = \sqrt{6}$$

The competitive edge has increased by a factor of  $\sqrt{6}$ .

8.  $\frac{1}{18}$ :

Pick real numbers to solve this problem. Set the radius of the original circle equal to 2. Therefore, the radius of the new circle is equal to 6. Once you compute the areas of both circles, you can find the ratio:

$$\frac{\text{Area of half the original circle}}{\text{Area of the new circle}} = \frac{2\pi}{36\pi} = \frac{1}{18}$$

9.  $-5: A_n = 3 - 8n$

$$A_1 = 3 - 8(1) = 3 - 8 = -5$$

10.  $-16: A_n = 3 - 8n$

$$A_{11} = 3 - 8(11) = 3 - 88 = -85$$

$$A_9 = 3 - 8(9) = 3 - 72 = -69$$

$$A_{11} - A_9 = -85 - (-69) = -16$$

11. **13.5:** The easiest way to solve this problem is to write equations for  $S_2$  and  $S_3$  in terms of the other items in the sequence and solve for  $S_2$ :

$$S_2 = \frac{S_3 + S_1}{2} \rightarrow S_2 = \frac{S_3 + 15}{2}$$

$$S_3 = \frac{S_4 + S_2}{2} \rightarrow S_2 = \frac{10.5 + S_2}{2}$$

Now substitute the expression for  $S_3$  into the first equation and solve:

$$S_2 = \frac{\left(\frac{10.5 + S_2}{2}\right) + 15}{2} \rightarrow 2S_2 = \left(\frac{10.5 + S_2}{2}\right) + 15 \rightarrow 4S_2 = 10.5 + S_2 + 30 \rightarrow 3S_2 = 40.5 \rightarrow S_2 = 13.5$$

By this logic,  $S_3 = \frac{10.5 + 13.5}{2} = 12$ .

$$\begin{aligned} 12. \mathbf{276:} f(x) &= 2(2\sqrt{3})^4 - (2\sqrt{3})^2 = 2(2)^4(\sqrt{3})^4 - (2)^2(\sqrt{3})^2 \\ &= (2 \cdot 16 \cdot 9) - (4 \cdot 3) \\ &= 288 - 12 = 276 \end{aligned}$$



13. **8:**  $k(3) = 27$  Therefore,

$$4(3)^3 a = 27 \rightarrow k(x) = 4x^3 \left(\frac{1}{4}\right) = x^3 \rightarrow k(2) = (2)^3 = 8$$

$$108a = 27$$

$$a = \frac{1}{4}$$

Therefore,  $k(2) = 4(2)^3 \frac{1}{4} = 2^3 = 8$ .



14. **44:** First, find the output value of the inner function:  $g(4) = 16$ .

Then, find  $f(16)$ :  $3(16) - \sqrt{16} = 48 - 4 = 44$ .

15.  $x = \{-1, 2\}$ : To find the values for which  $f(x) = g(x)$ , set the functions equal to each other.

$$2x^2 - 4 = 2x$$

$$2x^2 - 2x - 4 = 0$$

$$2(x^2 - x - 2) = 0$$

$$2(x - 2)(x + 1) = 0$$

$$\begin{aligned} x - 2 &= 0 \\ x &= 2 \end{aligned}$$

OR

$$\begin{aligned} x + 1 &= 0 \\ x &= -1 \end{aligned}$$

16. **C:**  $g(x) = |x - 1| - 1$ . This function is an absolute value, which typically has a V-shape. You can identify the correct graph by plotting the  $y$ -intercept  $(0, 0)$  and then trying  $x = 1$ , which yields  $g(1) = -1$  and the point  $(1, -1)$ .

Next, try  $x = 2$ :  $g(2) = |2 - 1| - 1 = 1 - 1 = 0$ . These three points fall on the V-shape.

17. **C:** The powers of 2 have a repeating pattern of 4 terms for their units digits:  $\{2, 4, 8, 6\}$ . That means that every fourth term, the pattern repeats. For instance, the 5th term has the same units as the 1st term, because  $5 - 1 = 4$ . So terms that are four terms apart, or a multiple of 4 terms apart, will have the same units digit.

The 34th term and the 26th term are  $34 - 26 = 8$  terms apart. Because 8 is a multiple of 4, the terms will have the same units digit. **The two quantities are equal.**

18. **B:**

$P \blacksquare Q = P + 2Q$  for all integers  $P$  and  $Q$ .

Quantity A

$$\begin{aligned} 11 \blacksquare 5 &= \\ (11) + 2 \times (5) &= \\ 11 + 10 &= 21 \end{aligned}$$

Quantity B

$$\begin{aligned} 5 \blacksquare 11 &= \\ (5) + 2 \times (11) &= \\ 5 + 22 &= 27 \end{aligned}$$

**Quantity B is greater.**

19. **C:** Plug in numbers to answer this question. Use a table to organize the information.

	old	new
<b>Length</b>	2	$2 \times 2 = 4$
<b>Width</b>	1	$W$
<b>Area</b>	2	$2 \times 6 = 12$

$$\begin{aligned} 4 \times W &= 12 \\ W &= 3 \end{aligned}$$

Compare the new width to the original.  $\frac{\text{New}}{\text{Old}} = \frac{3}{1} = 3$ . The width increased by a factor of 3.

**The two quantities are equal.**

9

**Chapter 6**

*of*

ALGEBRA

DRILL

SETS

## In This Chapter . . .

---

g

- Algebra Drill Sets

## Chapter Review: Drill Sets

### DRILL SET 1:

**Drill 1:** Evaluate the following expressions.

- $19 \times 5 =$
- $39 - (25 - 17) =$
- $17(6) + 3(6) =$
- $3(4 - 2) \div 2 =$
- $15 \times 3 \div 9 =$
- $(9 - 5) - (4 - 2) =$
- $14 - 3(4 - 6) =$
- $6/3 + 12/3 =$
- $-5 \times 1 \div 5 =$
- $\frac{-3+7}{-4} =$

**Drill 2:** Evaluate the following expressions.

- $(4)(-3)(2)(-1) =$
- $5 - (4 - (3 - (2 - 1))) =$
- $7 - (6 + 2) =$
- $7 - (6 - 2) =$
- $-4(5) - 12/(2 + 4) =$
- $-3(-2) + 6/3 - (-5) =$
- $-12 \times 2/(-3) + 5 =$
- $(6 \times 5) + 14/7 =$
- $32/(4 + 6 \times 2) =$
- $-10 - (-3)^2 =$

**Drill 3:** Evaluate the following expressions.

- $-5^2 =$
- $2^3/2 =$
- $-2^3/2 =$
- $(3^2 \times 24)/(2^3) =$
- $36/(2 + 2^2) \times 4 \times (4 + 2) =$
- $\sqrt{6^2} + (-3^3) =$
- $5^3 - 5^2 =$
- $\sqrt{81} - \sqrt{9} =$
- $[\sqrt{16} + (4 \times 2^3)]/(-2)^2 =$
- $(3 + (-2)^3)^2 - 3^2 =$

**Drill 4:** Evaluate the following expressions.

- $4^3 - 4^2 =$
- $5^{(2+1)} + 25 =$
- $(-2)^3 - 5^2 + (-4)^3 =$
- $(63/3^2)^3/7 =$
- $5(1) + 5(2) + 5(3) + 5(4) =$
- $\sqrt{3^4/9} =$
- $3 \times 7^2 =$
- $4^2(3 - 1) - 19 + 4(-2) =$
- $\frac{(3+7)(5-3)}{(5-4)(5-4)} =$
- $3 \times 99 - 2 \times 99 - 1 \times 99 =$

### DRILL SET 2:

**Drill 1:** Solve for the variable.

- $5x - 7 = 28$
- $14 - 3x = 2$
- $z - 11 = 1$
- $3(7 - x) = 4(1.5)$
- $7x + 13 = 2x - 7$
- $13 - (-2w) = 6 + 3(11)$
- $6a/3 = 12 + a$
- $13x + 2(x + 5) - 7x = -70$
- $(z - 4)/3 = -12$
- $y - 15/3 = 7$

**Drill 2:** Solve for the variable.

- $y + 3y = 28$
- $15z + (4z/2) = 51$
- $3t^3 - 7 = 74$
- $7(x - 3) + 2 = 16$
- $z/6 = -8$
- $1,200x + 6,000 = 13,200$
- $(1,300x + 1,700)/43 = 100$
- $90x + 160 + 5x - 30 + 5x - 30 = 900$
- $4(x + 2)^3 - 38 = 70$
- $4(5x + 2) + 44 = 132$

**Drill 3:** Solve for the variable.

- $\sqrt{x} = 3 \times 5 - 20 \div 4$
- $-(x)^3 = 64$

## Chapter 6

3.  $x^3 = 8$

4.  $4x^3 - 175 = 325$

5.  $9 = y^3/3$

6.  $-\sqrt{w} = -5$

7.  $\frac{\sqrt{3x+1}}{2} - 1 = 3$

8.  $128 = 2z^3$

9.  $5\sqrt[3]{x+6} = 51$

10.  $\frac{\sqrt{x-2}}{5} - 20 = -17$

**Drill 4:** Isolate  $x$ .

1.  $3x + 2(x + 2) = 2x + 16$

2.  $\frac{3x+7}{x} = 10$

3.  $4(-3x - 8) = 8(-x + 9)$

4.  $3x + 7 - 4x + 8 = 2(-2x - 6)$

5.  $2x(4 - 6) = -2x + 12$

6.  $\frac{3(6-x)}{2x} = -6$

7.  $\frac{13}{x+13} = 1$

8.  $\frac{10(3x+4)}{10-5x} = 2$

9.  $\frac{8-2(-4+10x)}{2-x} = 17$

10.  $\frac{50(10+3x)}{50+7x} = 50$

**DRILL SET 3:**

Solve for the value of both variables in each system of equations. Explanations will follow the four steps discussed in the chapter. Not every step will be necessary to answer every question.

**Drill 1:**

1.  $7x - 3y = 5$

$y = 10$

2.  $2h - 4k = 0$

$k = h - 3$

3.  $64 - 2y = x$

$y = 33$

4.  $3q - 2y = 5$

$y = 2q - 4$

5.  $5r - 7s = 10$

$r + s = 14$

**Drill 2:**

1.  $3x + 6y = 69$

$2x - y = 11$

2.  $4w - (5 - z) = 6$

$w - 3(z + 3) = 10$

3.  $6x + 15 = 3y$

$x + y = 14$

4.  $4c + 3t = 33$

$c + 6 = t + 2$

5.  $50x + 20y = 15$

$10x + 4y = 3$  (watch out!)

**Drill 3:** Practicing for Rates Problems

1.  $5(t + 1) = d$

$7t = d + 7$

2.  $4t = d$

$6(t - 1) = d + 4$

3.  $50t = d$

$30t = d - 40$

4.  $4r + 10t = 140$

$r + 25t = 170$

5.  $7t = d$

$5(t - 2) = d - 22$

Many Rates and Distance problems come down to setting up and solving two equations for two variables. Solving these systems of equations is good practice for when you review Rate problems for the GRE.

**Drill 4:** Practicing for Other Types of Word Problems

1.  $4x = 3y$

$x - 2y = -15$

2.  $12b = 2g$

$4g - 3b = 63$

3.  $y = 4x + 10$

$y = 7x - 5$

4.  $j + 10 = 2m$

$j = m - 3$

5.  $2s = t$

$s + t = 36$

**DRILL SET 4**

**Drill 1:** Distribute the following factored forms (using FOIL).

- $(x + 2)(x - 3) =$
- $(2s + 1)(s + 5) =$
- $(h - 3)(h + 6) =$
- $(5 + a)(3 + a) =$
- $(x + y)(x + y) =$

**Drill 2:** Distribute the following factored forms (using FOIL).

- $(y + 7)(y + 13) =$
- $(3 - z)(z + 4) =$
- $(x + 6)(x - 6) =$
- $(2x - y)(x + 4y) =$
- $(x^2 + 5)(x + 2) =$

**Drill 3:** Factor the following expressions.

- $18x + 24$
- $9y - 12y^2$
- $7x^3 + 84x$
- $40y + 30x$
- $5x^4 - 10x^3 + 35x$

**Drill 4:** Factor the following expressions.

- $3xy^2 + 6xy$
- $15a^2b + 30ab - 75ab^2$
- $2xyz + 6xy - 10yz$
- $4x^2 + 12x + 8$
- $2y^3 - 10y^2 + 12y$

**DRILL SET 5**

**Drill 1:** Solve the following equations. List all possible solutions.

- $x^2 - 2x = 0$
- $y^2 + 3y = 0$
- $z^2 = -5z$
- $44j - 11jk = 0$
- $4xy + 2x^2y = 0$

**Drill 2:** Solve the following equations. List all possible solutions.

- $y^2 + 4y + 3 = 0$
- $y^2 - 11y + 30 = 0$
- $y^2 + 12y + 36 = 0$
- $c^2 - 23c + 42 = 0$
- $w^2 + 17w + 60 = 0$

**Drill 3:** Solve the following equations. List all possible solutions.

- $a^2 - a - 12 = 0$
- $x^2 + 8x - 20 = 0$
- $b^2 - 4b - 32 = 0$
- $y^2 - 4y - 45 = 0$
- $x^2 + 9x - 90 = 0$

**Drill 4:** Solve the following equations. List all possible solutions.

- $2a^2 + 6a + 4 = 0$
- $y^2 - 7y + 4 = -6$
- $x^3 - 3x^2 - 28x = 0$
- $x^3 - 5x^2 + 4x = 0$
- $-3x^3 + 6x^2 + 9x = 0$



**Drill Set Answers****DRILL SET 1:****Set 1, Drill 1:**

1.  $19 \times 5 = 95$

Tip: 20 times 5 is 100. You have one less five.  $100 - 5 = 95$ . Or, use the calculator!

2.  $39 - (25 - 17) =$   
 $39 - 8 = 31$

Tip: You could distribute the minus sign ( $39 - 25 + 17$ ) if you prefer, but our method is less prone to error.

3.  $17(6) + 3(6) =$   
 $102 + 18 = 120$

Tip: If you add 3 sixes to 17 sixes, you will have 20 sixes.  $20 \times 6 = 120$ . Or, use the calculator!

4.  $3 \times (4 - 2) \div 2 =$   
 $3 \times (2) \div 2 =$   
 $6 \div 2 = 3$

5.  $15 \times 3 \div 9 =$   
 $45 \div 9 = 5$

6.  $(9 - 5) - (4 - 2) =$   
 $(4) - (2) = 2$

7.  $14 - 3(4 - 6) =$   
 $14 - 3(-2) =$   
 $14 + 6 = 20$

8.  $6/3 + 12/3 =$   
 $2 + 4 = 6$

9.  $-5 \times 1 \div 5 =$   
 $-5 \div 5 = -1$

10.  $\frac{-3+7}{-4} = \frac{4}{-4} = -1$

**Set 1, Drill 2:**

1.  $(4)(-3)(2)(-1) = 24$

Tip: To determine whether a product will be positive or negative, count the number of positive and negative terms being multiplied. An even number of negative terms will give you a positive product; an odd number of negative terms will give you a negative product.

2.  $5 - (4 - (3 - (2 - 1))) =$   
 $5 - (4 - (3 - 1)) =$   
 $5 - (4 - 2) =$   
 $5 - (2) = 3$

Tip: Start with the inner-most parentheses and be careful about the signs!

3.  $7 - (6 + 2) =$   
 $7 - (8) = -1$

4.  $7 - (6 - 2) =$   
 $7 - (4) = 3$

5.  $-4(5) - 12/(2 + 4) =$   
 $-20 - 12/(6) =$   
 $-20 - 2 = -22$

6.  $-3(-2) + 6/3 - (-5) =$   
 $6 + 2 + 5 = 13$

7.  $-12 \times 2/(-3) + 5 =$   
 $-24/(-3) + 5 =$   
 $8 + 5 = 13$

8.  $(6 \times 5) + 14/7 =$   
 $(30) + 2 = 32$

9.  $32/(4 + 6 \times 2) =$   
 $32/(4 + 12) =$   
 $32/(16) = 2$

10.  $-10 - (-3)^2 =$   
 $-10 - (9) = -19$

Watch out for the signs!

**Set 1, Drill 3:**

1.  $-5^2 =$   
 $-5^2 = -25$

Note: Make sure to read this as  $-(5^2)$ , NOT:  $(-5)^2 = 25$ , which would give us 25.

2.  $2^3/2 =$   
 $8/2 = 4$



**Chapter 6**

3.  $-2^3/2$   
 $-8/2 = -4$

4.  $(3^2 \times 24)/(2^3)$   
 $(9 \times 24)/8 = 216/8 = 27$



5.  $36/(2 + 2^2) \times 4 \times (4 + 2) =$   
 $36/(2 + 4) \times 4 \times (6) =$   
 $36/(6) \times 4 \times 6 =$   
 $6 \times 4 \times 6 = 144$

6.  $\sqrt{6^2} + (-3^3) =$   
 $6 + (-27) =$   
 $6 - 27 = -21$

7.  $5^3 - 5^2 =$   
 $125 - 25 = 100$

8.  $\sqrt{81} - \sqrt{9} =$   
 $9 - 3 = 6$

9.  $[\sqrt{16} + (4 \times 2^3)] / (-2)^2 =$   
 $[4 + (4 \times 8)] / 4 =$   
 $[4 + 32] / 4 = 36/4 = 9$

10.  $(3 + (-2)^3)^2 - 3^2 =$   
 $(3 - 8)^2 - 9 =$   
 $(-5)^2 - 9 = 25 - 9 = 16$

**Set 1, Drill 4:**

1.  $4^3 - (4)^2 =$   
 $64 - 16 = 48$

2.  $5^{(2+1)} + 25$   
 $5^3 + 25 = 125 + 25 = 150$

3.  $(-2)^3 - 5^2 + (-4)^3 =$   
 $(-8) - 25 + (-64) =$   
 $-33 - 64 = -97$

4.  $(63/3^2)^3/7$   
 $(63/9)^3/7 = 7^3/7 = 343/7 = 49$

5.  $5(1) + 5(2) + 5(3) + 5(4) =$   
 $5 + 10 + 15 + 20 = 50$

6.  $\sqrt{(3^4/9)}$   
 $\sqrt{(81/9)} = \sqrt{9} = 3$

7.  $3 \times 7^2 =$   
 $3 \times 49 =$   
**147**

8.  $4^2(3 - 1) - 19 + 4(-2) =$   
 $4^2(2) - 19 + (-8) =$   
 $16(2) - 19 - 8 =$   
 $32 - 27 = 5$

9.  $\frac{(3+7)(5-3)}{(5-4)(5-4)} = \frac{10 \times 2}{1 \times 1} = 20$

10.  $3 \times 99 - 2 \times 99 - 1 \times 99 =$   
 $99(3 - 2 - 1) =$   
 $99(0) = 0$

**DRILL SET 2:**

**Set 2, Drill 1:**

1.  $5x - 7 = 28$   
 $5x = 35$  Add 7  
 $x = 7$  Divide by 5

2.  $14 - 3x = 2$   
 $-3x = -12$  Subtract 14  
 $x = 4$  Divide by -3

3.  $z - 11 = 1$   
 $z = 12$  Add 11

4.  $3(7 - x) = 4(1.5)$   
 $21 - 3x = 6$  Simplify

$-3x = -15$  Subtract 21  
 $x = 5$  Divide by -3

5.  $7x + 13 = 2x - 7$   
 $5x + 13 = -7$  Subtract 2x  
 $5x = -20$  Subtract 13  
 $x = -4$  Divide by 5

**DRILL SETS ANSWER KEY**

**Chapter 6**

6.  $13 - (-2w) = 6 + 3(11)$   
 $13 + 2w = 6 + 33$  Simplify  
 $2w = 39 - 13$  Subtract 13  
 $2w = 26$  Divide by 2  
 $w = 13$
7.  $6a/3 = 12 + a$   
 $6a = 3 \times (12 + a)$  Multiply by 3  
 $6a = 36 + 3a$  Simplify  
 $3a = 36$  Subtract 3a  
 $a = 12$  Divide by 3
8.  $13x + 2(x + 5) - 7x = -70$   
 $13x + 2x + 10 - 7x = -70$  Simplify  
 $8x + 10 = -70$  Combine terms  
 $8x = -80$  Subtract 10  
 $x = -10$  Divide by 8
9.  $(z - 4)/3 = -12$   
 $z - 4 = -36$  Multiply by 3  
 $z = -32$  Add 4
10.  $y - 15/3 = 7$   
 $y - 5 = 7$  Simplify  
 $y = 12$  Add 5

**Set 2, Drill 2:**

1.  $y + 3y = 28$   
 $4y = 28$   
 $y = 7$
2.  $15z + (4z/2) = 51$   
 $15z + 2z = 51$   
 $17z = 51$   
 $z = 3$
3.  $3t^3 - 7 = 74$   
 $3t^3 = 81$   
 $t^3 = 27$   
 $t = 3$
4.  $7(x - 3) + 2 = 16$   
 $7(x - 3) = 14$   
 $x - 3 = 2$   
 $x = 5$

5.  $z/6 = -8$   
 $z = -48$
6.  $1,200x + 6,000 = 13,200$   
 $1,200x = 7,200$   
 $x = 6$
7.  $(1,300x + 1,700)/43 = 100$   
 $1,300x + 1,700 = 4,300$   
 $1,300x = 2,600$   
 $x = 2$
8.  $90x + 160 + 5x - 30 + 5x - 30 = 900$   
 $100x + 100 = 900$   
 $100x = 800$   
 $x = 8$
9.  $4(x + 2)^3 - 38 = 70$   
 $4(x + 2)^3 = 108$   
 $(x + 2)^3 = 27$   
 $x + 2 = 3$   
 $x = 1$
10.  $4(5x + 2) + 44 = 132$   
 $4(5x + 2) = 88$   
 $5x + 2 = 22$   
 $5x = 20$   
 $x = 4$

**Set 2, Drill 3:**

1.  $\sqrt{x} = 3 \times 5 - 20 + 4$   
 $\sqrt{x} = 15 - 5$   
 $\sqrt{x} = 10$   
 $x = 100$
2.  $-(x)^3 = 64$   
 $(x)^3 = -64$   
 $x = -4$
3.  $x^3 = 8$   
 $x = 2$
4.  $4x^3 - 175 = 325$   
 $4x^3 = 500$   
 $x^3 = 125$   
 $x = 5$

**Chapter 6**

5.  $9 = y^3/3$   
 $27 = y^3$   
 $3 = y$

6.  $-\sqrt{w} = -5$   
 $\sqrt{w} = 5$   
 $w = (5)^2$   
 $w = 25$

7.  $\frac{\sqrt{3x+1}}{2} - 1 = 3$   
 $\frac{\sqrt{3x+1}}{2} = 4$   
 $\sqrt{3x+1} = 8$   
 $3x+1 = 64$   
 $3x = 63$   
 $x = 21$

8.  $128 = 2z^3$   
 $64 = z^3$   
 $4 = z$

9.  $5\sqrt[3]{x} + 6 = 51$   
 $5\sqrt[3]{x} = 45$   
 $\sqrt[3]{x} = 9$   
 $x = 9^3 = 729$

10.  $\frac{\sqrt{x-2}}{5} - 20 = -17$   
 $\frac{\sqrt{x-2}}{5} = 3$   
 $\sqrt{x-2} = 15$   
 $x-2 = 15^2 = 225$   
 $x = 227$

**Set 2, Drill 4:**

1.  $3x + 2(x + 2) = 2x + 16$   
 $3x + 2x + 4 = 2x + 16$   
 $5x + 4 = 2x + 16$   
 $3x + 4 = 16$   
 $3x = 12$   
 $x = 4$

2.  $\frac{3x + 7}{x} = 10$

$3x + 7 = 10x$   
 $7 = 7x$   
 $1 = x$

3.  $4(-3x - 8) = 8(-x + 9)$   
 $-12x - 32 = -8x + 72$   
 $-32 = 4x + 72$   
 $-104 = 4x$   
 $-26 = x$

4.  $3x + 7 - 4x + 8 = 2(-2x - 6)$   
 $-x + 15 = -4x - 12$   
 $3x + 15 = -12$   
 $3x = -27$   
 $x = -9$

5.  $2x(4 - 6) = -2x + 12$   
 $2x(-2) = -2x + 12$   
 $-4x = -2x + 12$   
 $-2x = 12$   
 $x = -6$

6.  $\frac{3(6-x)}{2x} = -6$   
 $3(6-x) = -6(2x)$   
 $18 - 3x = -12x$   
 $18 = -9x$   
 $-2 = x$

7.  $\frac{13}{x+13} = 1$   
 $13 = 1(x+13)$   
 $13 = x+13$   
 $0 = x$

8.  $\frac{10(3x+4)}{10-5x} = 2$   
 $10(3x+4) = 2(10-5x)$   
 $30x+40 = 20-10x$   
 $40x+40 = 20$   
 $40x = -20$   
 $x = -1/2$

9.  $\frac{8-2(-4+10x)}{2-x} = 17$   
 $8-2(-4+10x) = 17(2-x)$   
 $8+8-20x = 34-17x$   
 $16-20x = 34-17x$

$$16 = 34 + 3x$$

$$-18 = 3x$$

$$-6 = x$$

$$10. \quad \frac{50(10+3x)}{50+7x} = 50$$

$$50(10+3x) = 50(50+7x)$$

$$10+3x = 50+7x$$

$$-40 = 4x$$

$$-10 = x$$

DRILL SET 3:**Set 3, Drill 1:**

1. Eq. (1):  $7x - 3y = 5$

$$7x - 3(10) = 5$$

$$7x - 30 = 5$$

$$7x = 35$$

$$x = 5$$

Answer:  $x = 5, y = 10$

2. Eq. (1):  $2h - 4k = 0$

$$2h - 4(h - 3) = 0$$

$$2h - 4h + 12 = 0$$

$$-2h = -12$$

$$h = 6$$

$$k = (6) - 3$$

$$k = 3$$

Answer:  $h = 6, k = 3$

3. Eq. (1):  $64 - 2y = x$

$$64 - 2(33) = x$$

$$64 - 66 = x$$

$$-2 = x$$

Answer:  $y = 33, x = -2$

4. Eq. (1):  $3q - 2y = 5$

$$3q - 2(2q - 4) = 5$$

$$3q - 4q + 8 = 5$$

$$-q + 8 = 5$$

$$-q = -3$$

$$q = 3$$

$$y = 2(3) - 4$$

$$y = 6 - 4$$

Eq. (2):  $y = 10$

(Step 2) Substitute (10) for  $y$  in Eq. (1).

(Step 3) Solve for  $x$ . Simplify grouped terms.

Add 30.

Divide by 7.

Eq. (2):  $k = h - 3$

(Step 2) Substitute  $(h - 3)$  for  $k$  in Eq. (1).

(Step 3) Solve for  $h$ . Simplify grouped terms.

Combine like terms.

Divide by  $-2$ .

(Step 4) Substitute (6) for  $h$  in Eq. 2 and solve for  $k$ . Simplify.

Eq. (2):  $y = 33$

(Step 2) Substitute (33) for  $y$  in Eq. (1).

(Step 3) Solve for  $x$ . Simplify.

Eq. (2):  $y = 2q - 4$

(Step 2) Substitute  $(2q - 4)$  for  $y$  in Eq. (1).

(Step 3) Solve for  $q$ . Simplify grouped terms.

Combine like terms.

Subtract 8.

Divide by  $-1$ .

(Step 4) Substitute (3) for  $q$  in Eq. (2). Solve for  $y$ . Simplify.

**Chapter 6**

$$y = 2$$

**Answer:  $q = 3, y = 2$**

5. Eq. (1):  $5r - 7s = 10$

$$r + s = 14$$

$$r = 14 - s$$

$$5(14 - s) - 7s = 10$$

$$70 - 5s - 7s = 10$$

$$70 - 12s = 10$$

$$70 = 10 + 12s$$

$$60 = 12s$$

$$5 = s$$

$$r + (5) = 14$$

$$r = 9$$

**Answer:  $r = 9, s = 5$**

Eq. (2):  $r + s = 14$

(Step 1) Isolate  $r$  in Eq. (2). Subtract  $s$ .(Step 2) Substitute  $(14 - s)$  for  $r$  in Eq. (1).

Simplify grouped terms.

Combine like terms.

Add  $12s$ .

Subtract 10.

Divide by 12.

(Step 4) Substitute (5) for  $s$  in Eq. (2). Solve for  $r$ .

Subtract 5.

**Set 3, Drill 2:**

1. Eq. (1):  $3x + 6y = 69$

$$2x - y = 11$$

$$-y = -2x + 11$$

$$y = 2x - 11$$

$$3x + 6(2x - 11) = 69$$

$$3x + 12x - 66 = 69$$

$$15x - 66 = 69$$

$$15x = 135$$

$$x = 9$$

$$2(9) - y = 11$$

$$18 - y = 11$$

$$18 = 11 + y$$

$$7 = y$$

**Answer:  $x = 9, y = 7$**

Eq. (2):  $2x - y = 11$

(Step 1) Isolate  $y$  in Eq. (2). Subtract  $2x$ .Divide by  $-1$ .(Step 2) Substitute  $(2x - 11)$  for  $y$  in Eq. (1).(Step 3) Solve for  $x$ . Simplify grouped terms.

Combine like terms.

Add 66.

Divide by 15.

(Step 4) Substitute (9) for  $x$  in Eq. (2). Solve for  $y$ .

Simplify.

Add  $y$ .

Subtract 11.

2. Eq. (1):  $4w - (5 - z) = 6$

$$4w - (5 - z) = 6$$

$$4w - 5 + z = 6$$

$$4w + z = 11$$

$$z = 11 - 4w$$

$$w - 3(z + 3) = 10$$

$$w - 3z - 9 = 10$$

$$w - 3z = 19$$

$$w - 3(11 - 4w) = 19$$

$$w - 33 + 12w = 19$$

Eq. (2):  $w - 3(z + 3) = 10$

Isolate  $z$  in Eq. (1). Simplify grouped terms.

Add 5.

Subtract  $4w$ .

Simplify Eq. (2). Simplify grouped terms.

Add 9.

(Step 2) Substitute  $(11 - 4w)$  for  $z$  in Eq. (2).(Step 3) Solve for  $w$ . Simplify grouped terms.

DRILL SETS ANSWER KEY

$$13w - 33 = 19$$

$$13w = 52$$

$$w = 4$$

$$z = 11 - 4w$$

$$z = 11 - 4(4)$$

$$z = 11 - 16$$

$$z = -5$$

Answer:  $w = 4$ ,  $z = -5$

3. Eq. (1):  $6x + 15 = 3y$

$$x + y = 14$$

$$x = 14 - y$$

$$6(14 - y) + 15 = 3y$$

$$84 - 6y + 15 = 3y$$

$$99 - 6y = 3y$$

$$99 = 9y$$

$$11 = y$$

$$x + 11 = 14$$

$$x = 3$$

Answer:  $x = 3$ ,  $y = 11$

4. Eq. (1):  $4c + 3t = 33$

$$c + 6 = t + 2$$

$$c + 4 = t$$

$$4c + 3(c + 4) = 33$$

$$4c + 3c + 12 = 33$$

$$7c + 12 = 33$$

$$7c = 21$$

$$c = 3$$

$$c + 6 = t + 2$$

$$(3) + 6 = t + 2$$

$$9 = t + 2$$

$$7 = t$$

Answer:  $c = 3$ ,  $t = 7$

5. Eq. (1):  $50x + 20y = 15$

$$10x + 4y = 3$$

$$50x + 20y = 15$$

Combine like terms.

Add 33.

Divide by 13.

Substitute (4) for  $w$  in the simplified form of Eq. (1).

Simplify.

Simplify.

Eq. (2):  $x + y = 14$

(Step 1) Isolate  $x$  in Equation 2. Subtract  $y$ .

(Step 2) Substitute  $(14 - y)$  for  $x$  in Eq. (1).

(Step 3) Solve for  $y$ . Simplify grouped terms.

Combine like terms.

Add  $6y$ .

Divide by 9.

(Step 4) Substitute (11) for  $y$  in Eq. (2). Solve for  $x$ .

Subtract 11.

Eq. (2):  $c + 6 = t + 2$

(Step 1) Isolate  $t$  in Eq. (2). Subtract 2.

(Step 2) Substitute  $(c + 4)$  for  $t$  in Eq. (1).

(Step 3) Solve for  $c$ . Simplify grouped terms.

Combine like terms.

Subtract 12.

Divide by 7.

(Step 4) Substitute (3) for  $c$  in Eq. (2). Solve for  $t$ .

Simplify.

Subtract 2.

Eq. (2):  $10x + 4y = 3$

Multiply Eq. (2) by 5

*Can't solve—these are the same equations!*

Tip: We can only solve two equations for two variables if the equations are different.

**Chapter 6****Set 3, Drill 3:**

1. Eq. (1):  $5(t + 1) = d$

$$5(t + 1) = d$$

$$5t + 5 = d$$

$$7t = (5t + 5) + 7$$

$$7t = 5t + 12$$

$$2t = 12$$

$$t = 6$$

$$7(6) = d + 7$$

$$42 = d + 7$$

$$35 = d$$

**Answer:  $t = 6, d = 35$**

Eq. (2):  $7t = d + 7$

(Step 1) Isolate  $d$  in Eq. (1). Simplify Eq. (1).(Step 2) Substitute  $(5t + 5)$  for  $d$  in Eq. (2).(Step 3) Solve for  $t$ . Simplify.Subtract  $5t$ .

Divide by 2.

(Step 4) Substitute  $(6)$  for  $t$  in Eq. (2). Solve for  $d$ .

Simplify.

Subtract 7.

2. Eq. (1):  $4t = d$

$$6t - 6 = d + 4$$

$$6t - 6 = (4t) + 4$$

$$6t = 4t + 10$$

$$2t = 10$$

$$t = 5$$

$$4(5) = d$$

$$20 = d$$

**Answer:  $t = 5, d = 20$**

Eq. (2):  $6(t - 1) = d + 4$

(Step 1) Simplify grouped terms in Eq. (2).

(Step 2) Substitute  $(4t)$  for  $d$  in Eq. (2).(Step 3) Solve for  $t$ . Add 6.Subtract  $4t$ .

Divide by 2.

(Step 4) Substitute  $(5)$  for  $t$  in Eq. (1). Solve for  $d$ .

Simplify.

3. Eq. (1):  $50t = d$

$$30t = 50t - 40$$

$$-20t = -40$$

$$t = 2$$

$$50(2) = d$$

$$100 = d$$

**Answer:  $t = 2, d = 100$**

Eq. (2):  $30t = d - 40$

(Step 2) Substitute  $(50t)$  for  $d$  in Eq. (2).(Step 3) Solve for  $t$ . Subtract  $50t$ .Divide by  $-20$ .(Step 4) Substitute  $(2)$  for  $t$  in Eq. (1). Solve for  $d$ .

4. Eq. (1):  $4r + 10t = 140$

$$r + 25t = 170$$

$$r = 170 - 25t$$

$$4(170 - 25t) + 10t = 140$$

$$680 - 100t + 10t = 140$$

$$680 - 90t = 140$$

$$-90t = -540$$

$$t = 6$$

$$4r + 10(6) = 140$$

$$4r + 60 = 140$$

$$4r = 80$$

Eq. (2):  $r + 25t = 170$

(Step 1) Isolate  $r$  in Eq. (2). Subtract  $25t$ .(Step 2) Substitute  $(170 - 25t)$  for  $r$  in Eq. (1).(Step 3) Solve for  $t$ . Simplify grouped terms.

Combine like terms.

Subtract 680.

Divide by  $-90$ .(Step 4) Substitute  $(6)$  for  $t$  in Eq. (1). Solve for  $r$ .

Simplify.

Subtract 60.

DRILL SETS ANSWER KEY

$r = 20$

Answer:  $t = 6, r = 20$

5. Eq. (1):  $7t = d$

$5t - 10 = (7t) - 22$

$5t + 12 = 7t$

$12 = 2t$

$6 = t$

$7(6) = d$

$42 = d$

Answer:  $t = 6, d = 42$

**Set 3, Drill 4:**

1. Eq. (1):  $4x = 3y$

$x - 2y = -15$

$x = -15 + 2y$

$4(-15 + 2y) = 3y$

$-60 + 8y = 3y$

$-60 = -5y$

$12 = y$

$4x = 3(12)$

$4x = 36$

$x = 9$

Answer:  $y = 12, x = 9$

2. Eq. (1):  $12b = 2g$

$12b = 2g$

$6b = g$

$4(6b) - 3b = 63$

$24b - 3b = 63$

$21b = 63$

$b = 3$

$12(3) = 2g$

$36 = 2g$

$g = 18$

Answer:  $b = 3, g = 18$

3. Eq. (1):  $y = 4x + 10$

$(4x + 10) = 7x - 5$

$10 = 3x - 5$

$15 = 3x$

Divide by 4.

Eq. (2):  $5(t - 2) = d - 22$

(Step 2) Substitute  $(7t)$  for  $d$  in Eq. (2).(Step 3) Solve for  $t$ . Add 22.Subtract  $5t$ .

Divide by 2.

(Step 4) Substitute  $(6)$  for  $t$  in Eq. (1). Solve for  $d$ .

Simplify.

Eq. (2):  $x - 2y = -15$

(Step 1) Isolate  $x$  in Eq. (2). Add  $2y$ .(Step 2) Substitute  $(-15 + 2y)$  for  $x$  in Eq. (1).(Step 3) Solve for  $y$ . Simplify grouped terms.Subtract  $8y$ .Divide by  $-5$ .(Step 4) Substitute  $12$  for  $y$  in Eq. (1).

Simplify.

Divide by 4.

Eq. (2):  $4g - 3b = 63$

(Step 1) Isolate  $g$  in Eq. (1). Divide by 2.(Step 2) Substitute  $(6b)$  for  $g$  in Eq. (2).(Step 3) Solve for  $b$ . Simplify.

Combine like terms.

Divide by 21.

(Step 4) Substitute  $(3)$  for  $b$  in Eq. (1). Solve for  $g$ .

Simplify.

Divide by 2.

Eq. (2):  $y = 7x - 5$

(Step 2) Substitute  $(4x + 10)$  for  $y$  in Eq. (2).(Step 3) Solve for  $x$ . Subtract  $4x$ .

Add 5.



**Chapter 6**

$$5 = x$$

$$y = 4(5) + 10$$

$$y = 30$$

$$\text{Answer: } x = 5, y = 30$$

4. Eq. (1):  $j + 10 = 2m$

$$(m - 3) + 10 = 2m$$

$$m + 7 = 2m$$

$$7 = m$$

$$j = (7) - 3$$

$$j = 4$$

$$\text{Answer: } m = 7, j = 4$$

5. Eq. (1):  $2s = t$

$$s + (2s) = 36$$

$$3s = 36$$

$$s = 12$$

$$2(12) = t$$

$$24 = t$$

$$\text{Answer: } s = 12, t = 24$$

Divide by 3.

(Step 4) Substitute (5) for  $x$  in Eq. (1). Solve for  $y$ .  
Simplify.

Eq. (2):  $j = m - 3$

(Step 2) Substitute  $(m - 3)$  for  $j$  in Eq. (1).(Step 3) Solve for  $m$ . Simplify.Subtract  $m$ .(Step 4) Substitute (7) for  $m$  in Eq. (2). Solve for  $j$ .  
Simplify.

Eq. (2):  $s + t = 36$

(Step 2) Substitute  $(2s)$  for  $t$  in Eq. (2).(Step 3) Solve for  $s$ . Combine like terms.

Divide by 3.

(Step 4) Substitute (12) for  $s$  in Eq. (1). Solve for  $t$ .  
Simplify.**DRILL SET 4:****Set 4, Drill 1:**

1.  $(x + 2)(x - 3) = x^2 - 3x + 2x - 6 = x^2 - x - 6$

2.  $(2s + 1)(s + 5) = 2s^2 + 10s + s + 5 = 2s^2 + 11s + 5$

3.  $(b - 3)(b + 6) = b^2 + 6b - 3b - 18 = b^2 + 3b - 18$

4.  $(5 + a)(3 + a) = 15 + 5a + 3a + a^2 = a^2 + 8a + 15$

5.  $(x + y)(x + y) = x^2 + xy + xy + y^2 = x^2 + 2xy + y^2$

**Set 4, Drill 2**

1.  $(y + 7)(y + 13) = y^2 + 13y + 7y + 91 = y^2 + 20y + 91$

2.  $(3 - z)(z + 4) = 3z + 12 - z^2 - 4z = -z^2 - z + 12$

3.  $(x + 6)(x - 6) = x^2 - 6x + 6x - 36 = x^2 - 36$

4.  $(2x - y)(x + 4y) = 2x^2 + 8xy - xy - 4y^2 = 2x^2 + 7xy - 4y^2$

**DRILL SETS ANSWER KEY****Chapter 6**

$$5. (x^2 + 5)(x + 2) = x^3 + 2x^2 + 5x + 10 = x^3 + 2x^2 + 5x + 10$$

**Set 4, Drill 3**

$$1. 18x + 24 = 6(3x + 4)$$

$$2. 9y - 12y^2 = 3y(3 - 4y)$$

$$3. 7x^3 + 84x = 7x(x^2 + 12)$$

$$4. 40y + 30x = 10(4y + 3x)$$

$$5. 5x^4 - 10x^3 + 35x = 5x(x^3 - 2x^2 + 7)$$

**Set 4, Drill 4**

$$1. 3xy^2 + 6xy = 3xy(y + 2)$$

$$2. 15a^2b + 30ab - 75ab^2 = 15ab(a + 2 - 5b)$$

$$3. 2xyz + 6xy - 10yz = 2y(xz + 3x - 5z)$$

$$4. 4x^2 + 12x + 8 = 4(x^2 + 3x + 2) = 4(x + 2)(x + 1)$$

$$5. 2y^3 - 10y^2 + 12y = 2y(y^2 - 5y + 6) = 2y(y - 3)(y - 2)$$

**DRILL SET 5:****Set 5, Drill 1**

$$1. x^2 - 2x = 0$$

$$x(x - 2) = 0$$

$$x = 0$$

$$\text{OR } (x - 2) = 0 \rightarrow x = 2$$

Answer:  $x = 0$  OR  $2$

$$2. y^2 + 3y = 0$$

$$y(y + 3) = 0$$

$$y = 0$$

$$\text{OR } (y + 3) = 0 \rightarrow y = -3$$

Answer:  $y = 0$  OR  $-3$

$$3. z^2 = -5z$$

$$z^2 + 5z = 0 \rightarrow z(z + 5) = 0$$

$$z = 0$$

$$\text{OR } (z + 5) = 0 \rightarrow z = -5$$

Answer:  $z = 0$  OR  $-5$

$$4. 44j - 11jk = 0$$

$$11j(4 - k) = 0$$

**Chapter 6**

$$11j = 0 \rightarrow j = 0$$

$$\text{OR } (4 - k) = 0 \rightarrow k = 4$$

Answer:  $j = 0$  OR  $k = 4$

5.  $4xy + 2x^2y = 0$

$$2xy(2 + x) = 0$$

$$2xy = 0 \rightarrow xy = 0 \rightarrow x = 0 \text{ OR } y = 0$$

$$\text{OR } (2 + x) = 0 \rightarrow x = -2$$

Answer:  $x = 0$  OR  $y = 0$  OR  $x = -2$

**Set 5, Drill 2**

1.  $y^2 + 4y + 3 = 0$

$$(y + 1)(y + 3) = 0$$

$$(y + 1) = 0 \rightarrow y = -1$$

$$(y + 3) = 0 \rightarrow y = -3$$

Answer:  $y = -1$  OR  $-3$

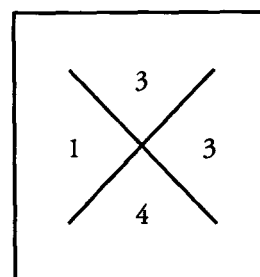

1 & 3 multiply to 3 and sum to 4.

2.  $y^2 - 11y + 30 = 0$

$$(y - 5)(y - 6) = 0$$

$$(y - 5) = 0 \rightarrow y = 5$$

$$\text{OR } (y - 6) = 0 \rightarrow y = 6$$

Answer:  $y = 5$  OR  $6$

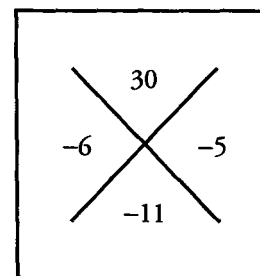

1 & 30, 2 & 15,  
3 & 10, and 5 & 6 multiply to 30. 5  
& 6 sum to 11.

3.  $y^2 + 12y + 36 = 0$

$$(y + 6)(y + 6) = 0$$

$$(y + 6) = 0 \rightarrow y = -6$$

$$\text{OR } (y + 6) = 0 \rightarrow y = -6$$

Answer:  $y = -6$   
(same result either way)

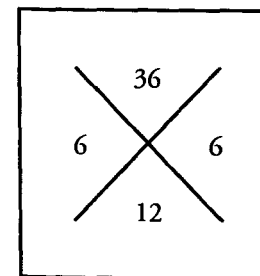

1 & 36, 2 & 18,  
3 & 12, 4 & 9, and  
6 & 6 multiply to 36. 6 & 6 sum to 12.

**DRILL SETS ANSWER KEY**

**Chapter 6**

4.  $c^2 - 23c + 42 = 0$

$(c - 21)(c - 2) = 0$

$(c - 21) = 0 \rightarrow c = 21$

OR  $(c - 2) = 0 \rightarrow c = 2$

Answer:  $c = 21$  OR  $2$

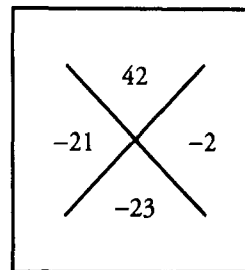

1 & 42, 2 & 21,  
3 & 14, and 6 & 7 multiply to 42.  
2 & 21 sum to 23.

5.  $w^2 + 17w + 60 = 0$

$(w + 12)(w + 5) = 0$

$(w + 12) = 0 \rightarrow w = -12$

OR  $(w + 5) = 0 \rightarrow w = -5$

Answer:  $w = -12$  OR  $-5$

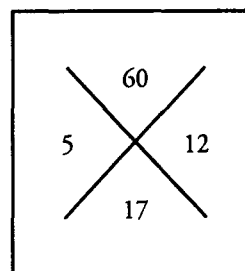

1 & 60, 2 & 30,  
3 & 20, 4 & 15,  
5 & 12, and 6 & 10 multiply to 60.  
5 & 12 sum to 17.

**Set 5, Drill 3**

1.  $a^2 - a - 12 = 0$

$(a - 4)(a + 3) = 0$

$(a - 4) = 0 \rightarrow a = 4$

OR  $(a + 3) = 0 \rightarrow a = -3$

Answer:  $a = 4$  OR  $-3$

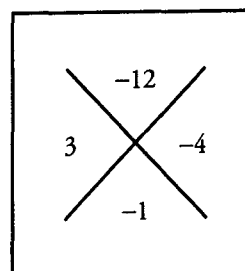

1 & 12, 2 & 6 and  
3 & 4 multiply to 12. The difference of  
3 & 4 is 1.

**Chapter 6**

**DRILL SETS ANSWER KE**

2.  $x^2 + 8x - 20 = 0$

$(x + 10)(x - 2) = 0$

$(x + 10) = 0 \rightarrow x = -10$

OR  $(x - 2) = 0 \rightarrow x = 2$

Answer:  $x = -10$  OR  $2$

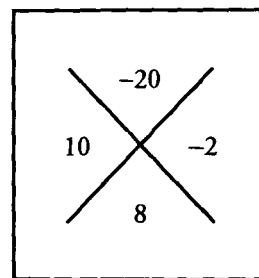

1 & 20, 2 & 10, and 4 & 5 multiply to 20. The difference of 2 & 10 is 8.

3.  $b^2 - 4b - 32 = 0$

$(b - 8)(b + 4) = 0$

$(b - 8) = 0 \rightarrow b = 8$

OR  $(b + 4) = 0 \rightarrow b = -4$

Answer:  $b = 8$  OR  $-4$

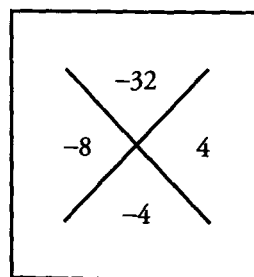

1 & 32, 2 & 16, and 4 & 8 multiply to 32. The difference of 4 & 8 is 4.

4.  $y^2 - 4y - 45 = 0$

$(y - 9)(y + 5) = 0$

$(y - 9) = 0 \rightarrow y = 9$

OR  $(y + 5) = 0 \rightarrow y = -5$

Answer:  $y = 9$  OR  $-5$

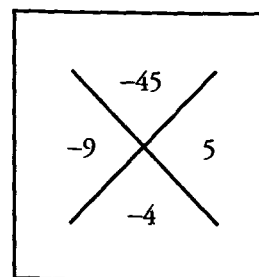

1 & 45, 3 & 15, and 5 & 9 multiply to 45. The difference of 5 & 9 is 4.

5.  $x^2 + 9x - 90 = 0$

$(x + 15)(x - 6) = 0$

$(x + 15) = 0 \rightarrow x = -15$

OR  $(x - 6) = 0 \rightarrow x = 6$

Answer:  $x = -15$  OR  $6$

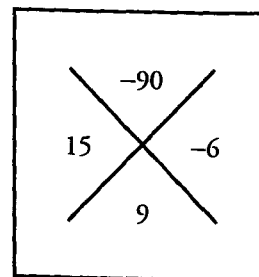

1 & 90, 2 & 45, 3 & 30, 5 & 18, 6 & 15, and 9 & 10 multiply to 90. The difference of 6 & 15 is 9.

**DRILL SETS ANSWER KEY****Chapter 6****Set 5, Drill 4**

1.  $2a^2 + 6a + 4 = 0$

$2(a^2 + 3a + 2) = 0 \rightarrow 2(a + 2)(a + 1) = 0$

$(a + 2) = 0 \rightarrow a = -2$

OR  $(a + 1) = 0 \rightarrow a = -1$

Answer:  $a = -2$  OR  $-1$ 

2.  $y^2 - 7y + 4 = -6$

$y^2 - 7y + 10 = 0 \rightarrow (y - 2)(y - 5) = 0$

$(y - 2) = 0 \rightarrow y = 2$

OR  $(y - 5) = 0 \rightarrow y = 5$

Answer:  $y = 2$  OR  $5$ 

3.  $x^3 - 3x^2 - 28x = 0$

$x(x^2 - 3x - 28) = 0 \rightarrow x(x - 7)(x + 4) = 0$

$x = 0$

OR  $(x - 7) = 0 \rightarrow x = 7$

OR  $(x + 4) = 0 \rightarrow x = -4$

Answer:  $x = 0$  OR  $7$  OR  $-4$ 

4.  $x^3 - 5x^2 + 4x = 0$

$x(x^2 - 5x + 4) = 0 \rightarrow x(x - 1)(x - 4) = 0$

$x = 0$

OR  $(x - 1) = 0 \rightarrow x = 1$

OR  $(x - 4) = 0 \rightarrow x = 4$

Answer:  $x = 0$  OR  $1$  OR  $4$ 

5.  $-3x^3 + 6x^2 + 9x = 0$

$-3x(x^2 - 2x - 3) = 0 \rightarrow -3x(x - 3)(x + 1) = 0$

$-3x = 0 \rightarrow x = 0$

OR  $(x - 3) = 0 \rightarrow x = 3$

OR  $(x + 1) = 0 \rightarrow x = -1$

Answer:  $x = 0$  OR  $3$  OR  $-1$

g

**Chapter 7**  
*of*  
ALGEBRA

ALGEBRA PRACTICE  
QUESTIONS SETS

## In This Chapter . . .

---

# g

- Easy Practice Question Set
- Medium Practice Question Set
- Hard Practice Question Set
- Easy Practice Question Solutions
- Medium Practice Question Solutions
- Hard Practice Question Solutions



## Algebra: Easy Practice Question Set

1.

$a, b, c$  are integers, such that  $a < b < c$ .

**Quantity A** $ac$ **Quantity B** $bc$ 

2.

$$\frac{x-1}{x} = 2$$

**Quantity A** $x$ **Quantity B** $-1$ 3. If  $r = 2s$  and  $t = 3r$ , what is  $s$  in terms of  $t$ ?

(A)  $\frac{t}{6}$

(B)  $\frac{t}{3}$

(C)  $\frac{2t}{3}$

(D)  $\frac{3t}{2}$

(E)  $6t$

4. If  $a + b = 2$  and  $3a - b = -14$ , then what is  $ab$ ?
5. Which of the following is a solution of  $x^2 + 2x - 8 = 7$ ?

(A)  $-4$

(B)  $-3$

(C)  $2$

(D)  $3$

(E)  $5$

6.

$x < 0$

**Quantity A** $|x|$ **Quantity B** $-x$

7. A sequence  $a_1, a_2, \dots$  is defined such that each term is 3 less than the preceding term. Which of the following equations is consistent with this definition?

- (A)  $a_{n+1} - 3 = a_n$
- (B)  $a_{n+1} + 3 = a_n$
- (C)  $3 - a_n = a_{n+1}$
- (D)  $3 - a_{n+1} = a_n$
- (E)  $a_n + 3 = a_{n+1}$

8.

$t > 1$

**Quantity A**

$$\frac{2t + 5}{3}$$

**Quantity B**

$3t$

9.

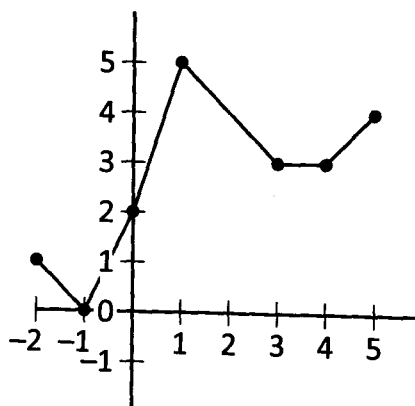

The plot above shows the graph of function  $f(x)$ . For what integer value of  $x$  in the interval shown does  $f(x) = x + 1$ ?

10. At a graduation, guests sit in rows such that there are  $p$  people in the first row,  $p + 1$  people sit in the second row,  $p + 2$  people sit in the third row, and so on. How many more people sit in row  $n$  than in the second row?

- (A)  $n + 2$
- (B)  $n + 1$
- (C)  $n$
- (D)  $n - 1$
- (E)  $n - 2$

11.  $\diamond n = \left(\frac{1}{n}\right)^n$  for all integers  $n > 0$ . What is the value of  $\diamond 3$ ?

- (A)  $\frac{1}{27}$   
 (B)  $\frac{1}{3}$   
 (C) 1  
 (D) 3  
 (E) 27

12.  $a \circ b = \frac{ab}{a+b}$  for all  $a, b$  that satisfy  $a \neq -b$ . What is the value of  $(-4) \circ 2$ ?

- (A) -4  
 (B) -2  
 (C)  $-\frac{4}{3}$   
 (D)  $\frac{4}{3}$   
 (E) 4

13. The flavor intensity  $F$  of a sauce is given by the formula  $F = \frac{P^3 S}{A^2}$ , where  $P$  is piquancy,  $S$  is sweetness and  $A$  is acidity. What is the flavor intensity of a sauce with piquancy of 2, sweetness of 1.2 and acidity of 0.4?

14.

$$c < -1$$

Quantity A

$$6c - 3$$

Quantity B

$$3c - 5$$

15. If  $8x - 14 - 2y = -10x$  and  $3x + 7y - 3 = 5y + 4$ , what is the value of  $x - y$ ?

- (A) -1  
 (B) 0  
 (C) 1  
 (D) 2  
 (E) 3

16.

The distance between  $q$  and  $-1$  on the number line equals 5.Quantity A

$|q|$

Quantity B

3

17.

$(3x + 1)(2x - 2) = 6x^2 - 10$

Quantity A

$x$

Quantity B

2

18.

$r + s + t > 1$  and  $0 > s + t$

Quantity A

1

Quantity B $r$ 

19.

$f(x) = 3x + 1$  and  $g(x) = x^2 - 3$

Quantity A

$f(4)$

Quantity B

$g(4)$

20. If  $p + q = 3$  and  $p - q = 17$ , then  $pq =$

Algebra: Medium Practice Question Set

1.

$x$  and  $y$  are positive integers and  $x > y$ .

**Quantity A**

$$x^2 - y^2$$

**Quantity B**

$$x + y$$

2.

**Quantity A**

$$(\sqrt{x} + \sqrt{y})(\sqrt{x} - \sqrt{y})$$

**Quantity B**

$$x - y$$

3.

$$5a + 3b = 2(a - b)$$

$$6a + 4b = 12$$

**Quantity A**

$$b$$

**Quantity B**

$$-5$$

4.

$$xy < 0 \text{ and } \frac{a}{x} > \frac{b}{y}$$

**Quantity A**

$$ay$$

**Quantity B**

$$bx$$

5. Consider the function  $f(x) = x^2 - 5x$ . For which value(s) of  $x$  does  $f(x) = 14$ ?

Indicate *all* that apply.

- A 19
- B 14
- C 7
- D 2
- E 0
- F -2
- G -7

6.

$$\left(\frac{p}{q}\right)^2 = 4$$

**Quantity A**

$p$

**Quantity B**

$2q$

7. If  $\frac{x+2y}{2x-y} = 2$ , then  $x =$

(A) 0

(B)  $\frac{4y}{5}$

(C)  $y$

(D)  $\frac{4y}{3}$

(E)  $3y$

8.  $(x+y)^2 - (x^2 - y^2) =$

(A)  $(x-y)^2$

(B)  $2y^2$

(C)  $2xy$

(D)  $2x(y-x)$

(E)  $2y(x+y)$

9. A function is defined by  $f(x) = x^2 + 4x - 5$ . What is the minimum value of  $f(x)$ ?

(A) 1

(B) 0

(C) -5

(D) -8

(E) -9

10.

$$x + y < 0$$

$$y - x > 0$$

**Quantity A**

$y$

**Quantity B**

0

11. If the product of  $\frac{ab}{c}$  and  $\frac{b}{cd}$  is negative, which two of the following must have a product that is less than zero?

Select the two choices that apply.

- A  $a$
- B  $b$
- C  $c$
- D  $d$

12. If the total weight of the pumpkins in a pumpkin patch increases by a factor of 10 while the number of pumpkins decreases by 20%, by what factor does the average weight of a pumpkin in the pumpkin patch increase?

- (A) 2
- (B) 8
- (C) 9.8
- (D) 12
- (E) 12.5

13. If  $3c + 2d = 8$  and  $c < -1$ , which one of the following could be a value for  $d$ ?

- (A) 2.5
- (B) 3.5
- (C) 4.5
- (D) 5.5
- (E) 6.5

14. Assume the function  $f(x)$  is defined as follows:  $f(x) = (x - 4)^2 + \sqrt{x + 3} + \frac{5}{x + 2}$ . For which of the following values of  $x$  is  $f(x)$  defined?

Indicate all such values.

- A -5
- B -4
- C -3
- D -2
- E -1

15. In a sequence  $a_1, a_2, \dots$ , each term is defined as  $a_n = \frac{1}{2^n}$ . Which of the following expressions represents the sum of the first 10 terms of  $a_n$ ?

(A)  $1 - \frac{1}{2^{10}}$

(B)  $1 - \frac{1}{2^9}$

(C)  $1 + \frac{1}{2^9}$

(D)  $1 + \frac{1}{2^{10}}$

(E)  $1 + \frac{1}{2^{11}}$

16.

Set A is the set of all integers  $x$  satisfying the inequality  $4 < |x| < 9$ .

**Quantity A**

**Quantity B**

The absolute value of the smallest integer in Set A

The number of integers in Set A

17.

$x$  and  $y$  are both positive integers.

**Quantity A**

**Quantity B**

$|x + y|$

$|x| - |y|$

18. If the average of  $x$  and  $y$  equals 40, the average of  $y$  and  $z$  equals 60, and the average of  $x$ ,  $y$  and  $z$  equals 30, then the average of  $x$  and  $z$  equals what?

19. A customer purchases pickles and onions from a local produce store. If an onion costs 3 times as much as a pickle, which two of the following sets of purchases would have the same cost?

Select the two choices that apply:

- A 9 onions and 3 pickles
- B 7 onions and 5 pickles
- C 7 onions and 9 pickles
- D 5 onions and 12 pickles
- E 5 onions and 14 pickles

20.  $x^2 - 10x + 13 = k$ . If one of the solutions to the equation is  $x = 4$ , what is the other solution for  $x$ ?



## Algebra: Hard Practice Question Set

CAUTION: These problems are *very difficult*—more difficult than many of the problems you will likely see on the GRE. Consider these “Challenge Problems.” Have fun!

1.  $f(x) = x^2 + 1$ . For which values of  $x$  does  $f(x) = f\left(\frac{1}{x}\right)$ ?

Indicate all such values:

A -2

B -1

C  $-\frac{1}{2}$

D  $\frac{1}{2}$

E 1

F 2

2. Given that  $x^3 + 3x^2 - 10x = 0$ , indicate all the possible values for the sum of any two solutions for  $x$ .

Indicate all that apply.

A -10

B -5

C -3

D -2

E 0

F 2

G 3

3. Each number  $S_N$  in a sequence can be expressed as a function of the preceding number ( $S_{N-1}$ ) as follows:

$S_N = \frac{2}{3}S_{N-1} - 4$ . Which of the following equations correctly expresses the value of  $S_N$  in this sequence in terms of  $S_{N+2}$ ?

(A)  $S_N = \frac{9}{4}S_{N+2} + 18$

(B)  $S_N = \frac{4}{9}S_{N+2} + 15$

(C)  $S_N = \frac{9}{4}S_{N+2} + 15$

(D)  $S_N = \frac{4}{9}S_{N+2} - 8$

(E)  $S_N = \frac{2}{3}S_{N+2} - 8$

4. If  $a > 0$  and  $b < 0$ , which of the following statements are true about the values of  $x$  that solve the equation  $x^2 - ax + b = 0$ ?

Indicate all such statements.

- A They have opposite signs.  
 B Their sum is greater than zero.  
 C Their product equals  $-b$ .

5. If  $r > 0$ ,  $s \neq \frac{1}{2}$  and  $r = \frac{3s+1}{1-2s}$ , then  $s =$

(A)  $\frac{3r}{12+6r}$

(B)  $-\frac{2r}{3}$

(C)  $\frac{r-1}{3+2r}$

(D)  $\frac{2}{3}(1-r)$

(E)  $\frac{-1+r}{3}$

6.

**Quantity A**

$$x(4-x)$$

**Quantity B**

6

7.

$n$  is an integer, and  $|2n + 7| \leq 10$ .

**Quantity A**

The difference between the largest and smallest possible values of  $n$

**Quantity B**

10

8.

$$s^2 + t^2 < 1 - 2st$$

**Quantity A**

$$1 - s$$

**Quantity B**

$t$

9. In a sequence  $a_1, a_2, \dots$ , each term after the first is found by taking the negative of the preceding term, and adding 1. If  $a_1 = 2$ , what is the sum of the first 99 terms?

- (A) 49
- (B) 50
- (C) 51
- (D) 99
- (E) 101

10. The cost of shipping a purchase is  $s$  dollars up to a purchase value of  $p$  dollars, plus an additional 5% of any excess of the purchase price over  $p$  dollars. If the value of a purchase is  $x$  dollars (where  $x > p$ ), what is the cost (in dollars) of shipping the purchase?

- (A)  $s + 0.05x$
- (B)  $s + 0.05p$
- (C)  $0.05(s - p + x)$
- (D)  $s + 0.05(x - p)$
- (E)  $s + 0.05(p - x)$

11. Caleb and Dan play a game in which the loser of each round gives one half of his marbles to the other player. They start out with  $4C$  and  $4D$  marbles, respectively. If Caleb wins the first round and Dan wins the second round, how many marbles does Dan have at the end of the second round?

- (A)  $2D$
- (B)  $2C + D$
- (C)  $2D + C$
- (D)  $3D + C$
- (E)  $3D + 2C$

12. Which of the following is the graph of the functional relationship  $\frac{1}{2}(y-1) = |x-4|$ ?

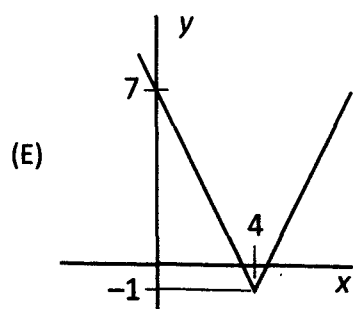
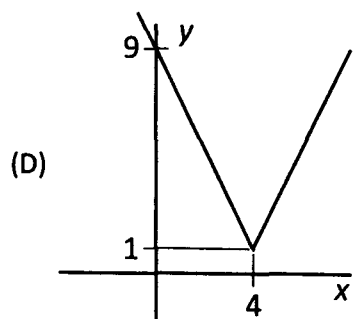
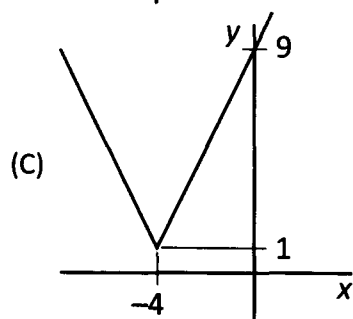
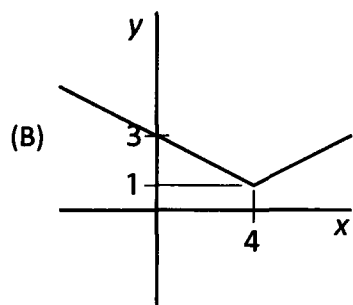
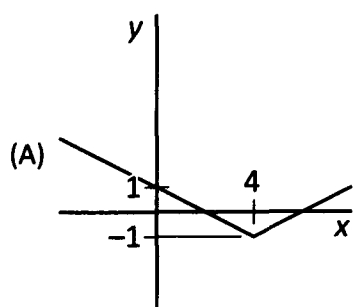

13. The stiffness of a diving board is proportional to the cube of its thickness and inversely proportional to the cube of its length. If diving board *A* is twice as long as diving board *B* and has 8 times the stiffness of diving board *B*, what is the ratio of the thickness of diving board *A* to that of diving board *B*? (Assume that the diving boards are equal in all respects other than thickness and length.)

14.

$$a = 5b^2 - 10b + 7$$

**Quantity A**

*a*

**Quantity B**

*b*

15.

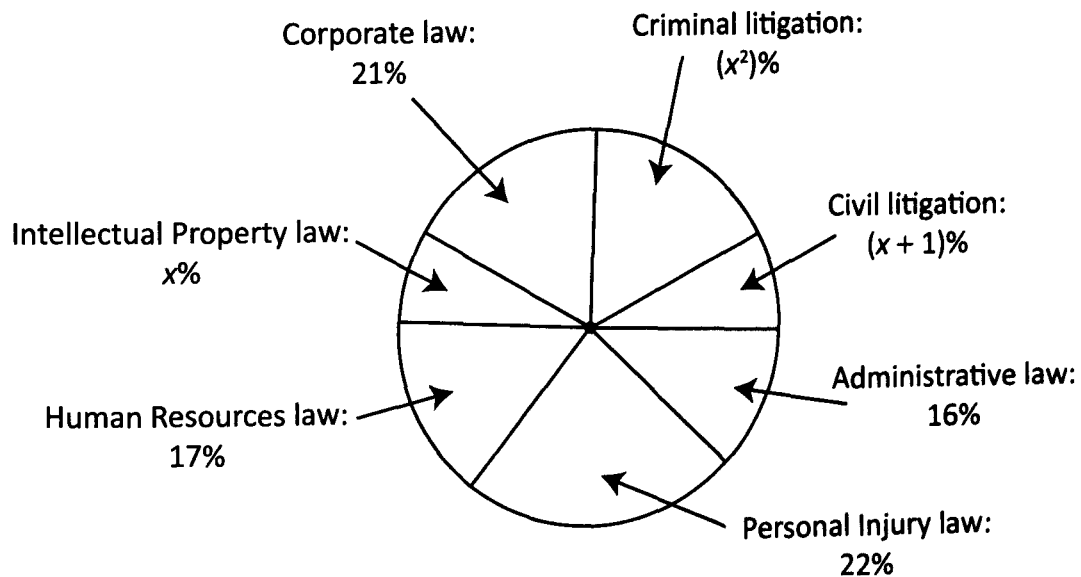

The circle graph above represents the type of law practiced by 55,000 members of an international law organization. The percentages represented are exact.

**Quantity A**

The number of lawyers in the organization who practice all types of litigation

**Quantity B**

The number of lawyers who practice corporate law

16. If  $|2z| - 1 \geq 2$ , which of the following graphs could be a number line representing all the possible values of  $z$ ?

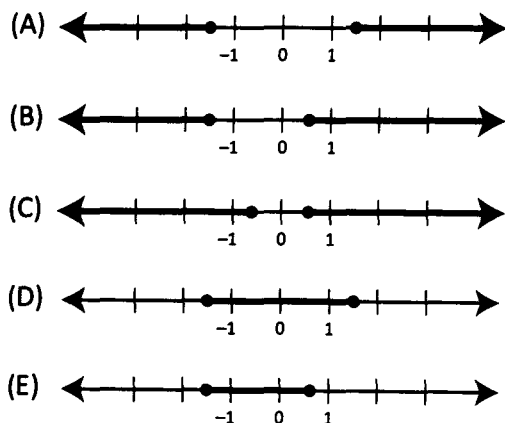

17. If  $a - b = 16$  and  $\sqrt{a} + \sqrt{b} = 8$  what is the value of  $\sqrt{ab}$ ?

- (A) 2
- (B) 4
- (C) 8
- (D) 12
- (E) 15

18.

$$\frac{2}{d} = \frac{2-d}{d-2}$$

Quantity A

$d$

Quantity B

0

19. The integer  $a$  is greater than 1 and is not equal to the square of an integer. Which of the following answer choices could potentially be equal to the square of an integer?

Indicate all that apply.

- (A)  $\sqrt{a}$
- (B)  $a^2 - 1$
- (C)  $a^2 + 1$
- (D)  $a^2 - a$
- (E)  $a^2 - 2a + 1$
- (F)  $2a$

20. If  $a = b \times c^2$  and  $c$  decreases by 20% while  $a$  remains constant, by what percent does  $b$  increase?

Round your answer to the nearest 0.1 percentage point:  %

## Algebra: Easy Practice Question Solutions

1. **D:** If all three numbers are positive,  $bc$  will be larger, because  $b > a$ . However, if all three numbers are negative, then  $ac$  will be larger. For example, if  $a = -5$ ,  $b = -4$ , and  $c = -3$ , then  $ac = 15$  and  $bc = 12$ . Therefore, **the relationship between the two quantities cannot be determined.**

2. **C:** Solve the equation for  $x$  by first multiplying both sides by  $x$  in order to clear the fraction:  $x - 1 = 2x$ . Next, collect all  $x$  terms on one side:  $-1 = 2x - x = x$ . Therefore  $x = -1$  and **the two quantities are equal.**

3. **A:** We can solve this problem in two ways. One is to use algebra. We want to relate  $s$  to  $t$ , when we have equations relating each of them to  $r$ . The problem is that one equation involves  $r$  and the other involves  $3r$ . We can get around this by multiplying the first equation by 3 on both sides, so as to obtain  $3r$ :

$$(3) \times r = (3) \times 2s, \text{ so } 3r = 6s. \text{ From the second equation, we know that } 3r = t. \text{ Therefore } 3r = 6s = t, \text{ so } s = \frac{t}{6}.$$

Our other option is to pick numbers. Suppose we set  $s = 2$ . Then, from the first equation,  $r = 4$ , and from the second equation,  $t = 3 \times 4 = 12$ , so  $s = \frac{t}{6}$ .

4. **-15:** We are given a system of two equations with two variables. Probably the simplest solution method in this case is to add the equations together, because  $+b$  and  $-b$  will cancel when we do so:

$$\begin{array}{r} a + b = 2 \\ + \quad 3a - b = -14 \\ \hline 4a = -12 \end{array}$$

Therefore,  $a = -3$ . We can then substitute this value into the first equation to obtain  $b = 5$ . Multiplication yields  $ab = (-3)(5) = -15$ .

5. **D:** In order to solve a quadratic equation, we must bring all terms to one side and factor:

$$\begin{array}{l} x^2 + 2x - 15 = 0 \\ (x + 5)(x - 3) = 0 \end{array}$$

The two solutions for  $x$  are  $-5$  and  $3$ . Only the latter appears in the answer choices.

6. **C:** The absolute value of a quantity is the quantity itself (if it is greater than or equal to zero) or the negative of the quantity (if the original quantity is less than or equal to zero). In this case, because we are told that  $x$  is negative, the absolute value of  $x$  is  $-x$ . For instance, if  $x = -3$ , then  $|x| = -(-3) = 3$ .

7. **B:** If each term in the sequence is 3 less than the preceding term, we can express the relationship as  $a_{n+1} = a_n - 3$ . Adding 3 to both sides results in  $a_{n+1} + 3 = a_n$ . Alternatively, we could pick representative numbers. Suppose  $a_n = 5$  and  $a_{n+1} = 2$ . We can determine that Choice B is correct by substituting these values into the five answer choices—all the Choices besides Choice B fail.

8. **B:** First, multiply both sides by 3 to clear the fraction. Multiplying by a positive number does not affect the comparison:

$$2t + 5 \qquad 9t$$

Now subtract  $2t$  from both columns (again, not affecting the comparison):

$$5 \qquad 7t$$

Because  $t > 1$ ,  $7t$  is greater than 5. Therefore **Quantity B is greater.**

9. **-1:** We can solve this problem by inspection of the graph. For more detail and verification, values of the function are tabulated below.

$x$	$x + 1$	$f(x)$
-2	-1	1
-1	0	0
0	1	2
1	2	5
2	3	4
3	4	3
4	5	3
5	6	4

It is clear that the only integer value of  $x$  for which  $f(x) = x + 1$  is  $x = -1$ .

10. **E:** We can calculate the data to better observe the pattern:

Row	Number of people
1	$p$
2	$p + 1$
3	$p + 2$
...	...
$n$	$p + (n - 1)$

The desired difference is found by  $p + (n - 1) - (p + 1) = n - 1 - 1 = n - 2$ . Another, perhaps more elegant method is to observe that the difference in the number of people seated in any two rows is equal to the difference in the row numbers themselves. For example, there is 1 more person seated in row 2 versus row 1 ( $2 - 1 = 1$ ), 2 more people seated in row 3 versus row 1 ( $3 - 1 = 2$ ), and so on. Therefore, there will be  $n - 2$  more people seated in row  $n$  than in row 2.

11. **A:**  $\diamond = \left(\frac{1}{3}\right)^3 = \frac{1}{3^3} = \frac{1}{27}$ .



12. **E:**  $(-4) \circ 2 = \frac{(-4) \times 2}{-4 + 2} = \frac{-8}{-2} = 4$ . Note that this is *not* the same as  $-(4 \circ 2)$ .

13. **60:** Plug the given values into the formula and evaluate:  $F = \frac{2^3 \times 1.2}{(0.4)^2} = \frac{8 \times 1.2}{0.16} = \frac{9.6}{0.16} = 60$ . If the calculator is

used in this problem, one must be careful to use parentheses around  $(0.4)^2$  in the denominator, as otherwise the operations “ $\div 0.4 \times 0.4$ ” would cancel each other out.



14. **B:** We should manipulate the quantities so that the  $c$  terms are together and the constant terms are together. This can be done by subtracting  $3c$  from both quantities, and adding 3 to both quantities:

$$\begin{array}{r} 6c - 3 \\ 6c - 3c \\ 3c \end{array} \qquad \begin{array}{r} 3c - 5 \\ -5 + 3 \\ -2 \end{array}$$

Next we divide both sides by 3 to isolate  $c$ :

$$\begin{array}{r} c \\ -\frac{2}{3} \end{array}$$

Since the problem explicitly states that  $c < -1$ , we know that Quantity A will always be more negative than Quantity B. Thus **Quantity B is greater**.

15. **A:** We should add/subtract terms to move the  $x$  and  $y$  terms to the left-hand side of the equation and the constant terms to the right-hand side of the equation:

$$\begin{array}{l} 8x - 14 - 2y = -10x \quad \rightarrow \quad 18x - 2y = 14 \\ 3x + 7y - 3 = 5y + 4 \quad \rightarrow \quad 3x + 2y = 7 \end{array}$$

Next, we can eliminate the  $y$  terms by adding the two equations together:

$$\begin{array}{r} 18x - 2y = 14 \\ + 3x + 2y = 7 \\ \hline 21x \quad = 21 \end{array}$$

Therefore  $x = 1$ , and we can plug this back into the second equation to find  $y = 2$ . Therefore  $x - y = -1$  and **Choice A is correct**.

16. **A:** Since  $q$  is 5 units away from  $-1$  on the number line,  $q = 4$  or  $-6$ .

This gives values for  $|q|$  of either 4 or 6, both of which are larger than 3. Therefore **Quantity A is larger**.

17. **C:** We can use FOIL to distribute the left-hand side of the given equation:

$$(3x + 1)(2x - 2) = 6x^2 - 10$$

$$6x^2 - 6x + 2x - 2 = 6x^2 - 10$$

Eliminating the  $6x^2$  terms from each side:

$$-6x + 2x - 2 = -10$$

$$-4x = -8$$

$$x = 2$$

Thus **the two quantities are equal.**

18. **B:** The given information tells us that  $r + s + t > 1$  and that the sum of  $s$  and  $t$  is negative. We can reason thusly: in order for the left hand side of that first inequality ( $r + s + t$ ) to be greater than 1 given that  $(s + t)$  is negative,  $r$  will certainly have to be greater than 1. If, for example,  $(s + t) = -1$ , then  $r$  will have to be greater than 2. If, for example,  $(s + t) = -5$ , then  $r$  will have to be greater than 6. If  $(s + t)$  is just barely less than zero, then  $r$  will have to be at least just barely greater than 1. Therefore  $r$  will always be greater than 1.

Alternatively, we could simply line up the two inequalities and add them together:

$$\begin{array}{r} r + s + t > 1 \\ + \quad \quad \quad 0 > \quad s + t \\ \hline r + s + t > 1 + s + t \end{array}$$

Since  $(s + t)$  appears on both sides of the inequality, we can subtract  $(s + t)$  from both sides to arrive at  $r > 1$ . Thus **Quantity B is greater.**

19. **C:**  $f(4) = 3(4) + 1 = 13$  and  $g(4) = 4^2 - 3 = 13$ . Therefore **the two quantities are equal.**

20. **-70:** Because the  $q$  terms have equal coefficients of opposite signs in the two equations, we can add the equations together to solve for  $p$  quickly—the  $q$  terms will drop out when the equations are added together:

$$\begin{array}{r} p + q = 3 \\ + \quad p - q = 17 \\ \hline 2p \quad = 20 \end{array}$$

Thus  $p = 10$ . Plugging this back into the first equation,  $(10) + q = 3$ , so we get  $q = -7$ , and thus  $pq = (10)(-7) = -70$ .

## Algebra: Medium Practice Question Solutions

1. **D:** It is helpful to recognize that  $x^2 - y^2$  factors into  $(x + y)(x - y)$ . Thus,  $x - y$  is the difference between Quantity A and Quantity B. Since  $x > y$ ,  $x - y$  must be positive. Thus, Quantity A will usually be larger. However,  $x - y$  could equal 1, in which case the Quantities will be equal. Therefore, **the relationship between the two quantities cannot be determined.**

2. **C:** The efficient approach to this problem is to recognize that this is a variant of the **difference of squares** special product:  $(a + b)(a - b) = a^2 - b^2$ . The distinction is that each of the exponents in this expression is halved (remember,  $x^{1/2} = \sqrt{x}$ ). Thus **the two quantities are equal.**

Otherwise, the problem can be solved by distributing the expression in Quantity A to get:

$$(\sqrt{x} + \sqrt{y})(\sqrt{x} - \sqrt{y}) = x - \sqrt{xy} + \sqrt{xy} - y = x - y.$$

Alternatively, we can pick numbers. For example, if we pick  $x = 25$  and  $y = 4$ , we get:

$$(\sqrt{25} + \sqrt{4})(\sqrt{25} - \sqrt{4}) = (5 + 2)(5 - 2) = (7)(3) = 21, \text{ and } 25 - 4 = 21.$$

3. **A:** The easiest way to determine a value for  $b$  is to manipulate and combine the equations to eliminate  $a$ . To begin with, simplify the first equation by distributing the 2 and combining like terms:

$$5a + 3b = 2(a - b)$$

$$5a + 3b = 2a - 2b$$

$$5b = -3a$$

$$-3a = 5b$$

Since we want the  $a$  terms in the two equations to cancel out, we can multiply this equation through by 2:

$$-6a = 10b$$

It is now possible to add the two equations and cancel out the  $a$  terms.

$$\begin{array}{r} 6a + 4b = 12 \\ + \quad -6a \quad = 10b \\ \hline 4b = 12 + 10b \\ -12 = 6b \\ -2 = b \end{array}$$

Therefore, **Quantity A is greater.**

Alternatively, we could have solved for  $a$  in one equation, plugged this expression into the second equation, and solved for  $b$ .

4. **B:** Since  $xy$  is less than 0,  $x$  and  $y$  must have opposite signs. Because we know one of them is negative, when we simplify the second expression (by multiplying through by  $xy$ ), we must flip the inequality sign, yielding:

$$(xy)\frac{a}{x} > \frac{b}{y}(xy) \rightarrow ay < bx.$$

Therefore **Quantity B is greater.**

5. **C and F:** Setting the value of  $f(x) = 14$  in the original function gives us the quadratic equation  $x^2 - 5x = 14$ . We subtract 14 from both sides to get  $x^2 - 5x - 14 = 0$ . We now need to find two real numbers such that the product of the numbers is  $-14$  and the sum is  $-5$ . The numbers we are looking for are  $-7$  and  $2$  ( $2$  and  $7$  are the only prime factors of  $14$ , which makes this a fairly easy search). We can therefore rewrite our equation as  $(x - 7)(x + 2) = 0$ , resulting in a solution set for  $x$  of  $\{-2, 7\}$ .

Alternatively, we could try plugging each of the answer choices into the function to determine which  $x$  values result in a function value of  $14$ . Only Choices C and F accomplish this.

6. **D:** The square of  $\frac{p}{q}$  equals  $4$ , so  $\frac{p}{q}$  must equal either  $2$  or  $-2$ . In the former case,  $p = 2q$ , while in the latter case,  $p = -2q$ . Therefore **it cannot be determined which quantity is greater.** Note that we might reach the wrong answer if we were to work backwards from the comparison to the equation, by assuming that the two quantities are equal:  $p = 2q$  certainly satisfies the given equation, but it is not the only solution.

7. **D:** First eliminate the fraction by multiplying both sides by  $2x - y$ :

$$x + 2y = 2(2x - y) = 4x - 2y$$

Next, collect  $x$  terms on one side and  $y$  terms on the other:

$$2y + 2y = 4x - x, \text{ or } 4y = 3x$$

Finally divide by  $3$  to solve for  $x$ :  $x = \frac{4y}{3}$ .

8. **E:** Expand the first term and subtract:  $(x + y)^2 - (x^2 - y^2) = x^2 + 2xy + y^2 - x^2 + y^2 = 2y^2 + 2xy = 2y(x + y)$ . Note that, when  $(x^2 - y^2)$  is subtracted, the leading minus sign applies to both terms, turning the  $-y^2$  into  $-(-y^2) = y^2$ .

Alternatively, we could pick numbers. Suppose that  $x = 3$  and  $y = 2$ . In that case,  $(x + y)^2 = 5^2 = 25$  and  $x^2 - y^2 = 9 - 4 = 5$ , so that the final result is  $25 - 5 = 20$ . Only Choice E gives this result when we substitute our values for  $x$  and  $y$ .

9. **E:** We can factor this quadratic as follows:  $x^2 + 4x - 5 = (x - 1)(x + 5)$ . This means that the solutions for  $f(x) = 0$  are  $x = 1$  and  $x = -5$ . A quadratic reaches its extreme value halfway between these solutions—i.e., when  $x = \frac{1 + (-5)}{2} = -2$ . Thus, the extreme value is  $f(-2) = 4 + 4(-2) - 5 = -9$ . Alternatively, we could make a table of values for  $x$  and  $f(x)$ :

$x$	-5	-4	-3	-2	-1	0	1
$f(x)$	0	-5	-8	-9	-8	-5	0

Of course, the challenge with tabulating values is that one does not know ahead of time what values to try, so the amount of effort involved could be substantial—with plenty of room for mathematical error.

10. **D:** The most effective way to combine two inequalities is to line up the inequality symbols and add both sides. However, this can only be done if the inequality symbols face in the same direction. That is not the case here. Therefore, our first step is to “flip” one of the inequalities. We can do so by multiplying both sides of the second inequality by  $-1$ , for example:

$$\begin{aligned}x + y &< 0 \\x - y &< 0\end{aligned}$$

At this point we can add the inequalities, resulting in  $2x < 0$  or, dividing by 2,  $x < 0$ . We know from the original form of the second inequality (by subtracting  $x$  from both sides of the inequality) that  $y$  is greater than  $x$ . However, we still do not know whether  $y$  is greater than or less than 0.

11. **A and D:** We are given the following relationship:  $\left(\frac{ab}{c}\right)\left(\frac{b}{cd}\right) < 0$ . Multiplying out gives  $\frac{ab^2}{c^2d} < 0$ . Because they are squares,  $b^2$  and  $c^2$  must be positive, so we can divide through by those expressions to obtain  $\frac{a}{d} < 0$ . This can only be true when  $a$  and  $d$  have opposite signs. In that case, their product will be negative as well.

12. **E:** The simplest way to solve a problem such as this (a formula problem with unspecified amounts) is to make the math concrete by picking suitable numbers. Suppose that initially there were 10 pumpkins in the patch, with a total weight of 20 pounds. The average weight of a pumpkin in the patch was therefore  $\frac{20}{10} = 2$  pounds. Afterwards, the total weight of the pumpkins increased to  $20 \times 10 = 200$  pounds, while the number of pumpkins decreased to  $10 - \frac{20}{100} \times 10 = 8$ . The new average weight of a pumpkin in the patch is  $\frac{200}{8} = 25$  pounds. The average weight has increased by a factor of  $\frac{25}{2} = 12.5$ .

13. **E:** The first step is to solve for  $d$  in terms of  $c$ :

$$3c + 2d = 8$$

$$2d = 8 - 3c$$

$$d = \frac{8 - 3c}{2} = 4 - 1.5c$$

Given that  $c < -1$ , we can use Extreme Values to solve for  $d$  by setting  $c$  equal to LT(-1):

$$d = 4 - 1.5c = 4 - 1.5 \times \text{LT}(-1) = 4 + \text{GT}(1.5) = \text{GT}(5.5)$$

Thus  $d$  must be *greater than* 5.5, and only Choice E fits this description. Note the switch from LT to GT: subtracting a “less than” Extreme Value is the same as adding a “greater than” Extreme Value.

14. **C and E:** Because  $f(x)$  includes the term  $\sqrt{x+3}$ ,  $x$  cannot be less than  $-3$ , because the square root of a negative number is not a real number. This eliminates Choices A and B. Furthermore, because  $f(x)$  includes the term  $\frac{5}{x+2}$ ,  $x$  cannot equal  $-2$ , because any fraction with 0 in the denominator is either undefined or indeterminate. Therefore, Choice D is eliminated. Only Choices C and E remain.

Note that the first term in the function,  $(x-4)^2$ , does not affect the range of potential values for  $x$ . That term is defined for any value of  $x$ .

15. **A:** Calculate the first few terms of the sequence using the definition  $a_n = \frac{1}{2^n}$  and keep a running total of the sum:

$n$	$a_n$	Sum of $a_1$ through $a_n$
1	$\frac{1}{2^1} = \frac{1}{2}$	$\frac{1}{2}$
2	$\frac{1}{2^2} = \frac{1}{4}$	$\frac{3}{4}$
3	$\frac{1}{2^3} = \frac{1}{8}$	$\frac{7}{8}$
4	$\frac{1}{2^4} = \frac{1}{16}$	$\frac{15}{16}$

We can see that the denominator of the sum is always equal to  $2^n$ , and the numerator is always one less than that. Thus, the pattern for the running sum through  $n$  terms is:

$$\text{Running sum} = \frac{2^n - 1}{2^n}$$

Substituting 10 for  $n$  and splitting the numerator into 2 fractions yields Choice A.

16. **C:** In terms of positive integers satisfying the inequality, only the following integers work: {5, 6, 7, 8}. Thus 4 positive integers satisfy the inequality.

Similarly, only the following negative integers satisfy the inequality: {-5, -6, -7, -8}. Thus 4 negative integers satisfy the inequality.

In total, there are 8 integers in  $A$ , and the smallest integer is  $-8$ . That integer has an absolute value of 8, so **the two quantities are equal**.

17. **A:** If both integers are positive, then the values of  $x$  and  $y$  will be additive within the absolute value term in Quantity A. Therefore, subtracting the absolute value of  $y$  from the absolute value of  $x$  will result in a total that is smaller than the value inside the absolute value expression in Quantity A. Thus **Quantity A will be larger**.

Note that this would also be the case if both  $x$  and  $y$  were negative, while Quantity A would equal Quantity B whenever  $x$  and  $y$  have opposite signs, as the magnitudes of the values inside the absolute value expression in Quantity A would be in opposite directions and partially cancel each other out.

For examples of these scenarios, we can test the expressions with  $x$  equal to  $\pm 6$  and  $y$  equal to  $\pm 2$ . Note that the Quantity A and B expressions are, again, equal when  $x$  and  $y$  have opposite signs, but Quantity A is larger when they have the same sign.

$x$	$y$	$ x + y $	$ x  -  y $
6	2	8	4
6	-2	4	4
-6	2	4	4
-6	-2	8	4

18. **-10:** We can convert the averages to sums by simply multiplying the average by the number of terms in each expression given. Thus,  $x + y = (2) \times 40 = 80$ ,  $y + z = (2) \times 60 = 120$ , and  $x + y + z = (3) \times 30 = 90$ .

The easiest way to solve this system of 3 variables and 3 equations is to subtract the first equation from the last, eliminating  $x$  and  $y$  immediately and giving us a value for  $z$ :

$$\begin{array}{r} x + y + z = 90 \\ - (x + y) = -80 \\ \hline z = 10 \end{array}$$

Plugging this value into the second equation, we see  $y + 10 = 120$ , so  $y = 110$ ; plugging into the first equation,  $x + 110 = 80$ , so  $x = -30$ .

Thus  $x + z = (-30) + 10 = -20$ , and the average of  $x$  and  $z = -10$ .

Note that we could also have started by subtracting the second equation from the last equation, solving first for  $y$  and then using that value to find  $x$  and  $z$ .

19. **A and C:** Perhaps the easiest way to solve this problem is to pick numbers and see which combinations of pickles and onions cost the same amount. Since onions cost 3 times as much as pickles, let us choose \$6 for the cost of an onion and \$2 for the cost of a pickle. Furthermore, let us use  $O$  for the cost of an onion purchased and  $P$  for the cost of a pickle.

Choice A translates to  $9O + 3P = 9(\$6) + 3(\$2) = \$60$ .

Choice B translates to  $7O + 5P = 7(\$6) + 5(\$2) = \$52$ .

Choice C translates to  $7O + 9P = 7(\$6) + 9(\$2) = \$60$ .

Choice D translates to  $5O + 12P = 5(\$6) + 12(\$2) = \$54$ .

Choice E translates to  $5O + 14P = 5(\$6) + 14(\$2) = \$58$ .

Therefore **Choices A and C are equal.**

20. **6:** When solving a quadratic equation, one must factor the original quadratic expression such that the constant terms in the two factors sum to the value of the coefficient in the  $x$  term (in this case,  $-10$ ):

$$(x - 4)(x + ?) = 0$$

In this case,  $(-4)$  and “?” must sum to  $-10$ , so “?” must equal  $-6$ . Therefore the other solution is  $x = 6$ .

Note that plugging 4 in for  $x$  in the original equation yields a value of  $-11$  for  $k$ :

$$(4)^2 - 10(4) + 13 = k$$

$$16 - 40 + 13 = k$$

$$-11 = k$$

By way of verification, we can see that we have arrived at the correct answer by plugging 6 in for  $x$  in the equation and seeing that it too produces a value of  $-11$  for  $k$ :

$$(6)^2 - 10(6) + 13 = k$$

$$36 - 60 + 13 = k$$

$$-11 = k$$



## Algebra: Hard Practice Question Solutions

1. **B and E:** If  $f(x) = x^2 + 1$ , then  $f\left(\frac{1}{x}\right)$  can be written as  $f\left(\frac{1}{x}\right) = \left(\frac{1}{x}\right)^2 + 1$ , where we have simply substituted  $\frac{1}{x}$  for  $x$ . Setting these two equations equal yields:

$$x^2 + 1 = \left(\frac{1}{x}\right)^2 + 1 = \frac{1}{x^2} + 1 = \frac{x^2 + 1}{x^2}.$$

Multiplying through by  $x^2$ , we see that  $x^4 + x^2 = 1 + x^2$ , or  $x^4 = 1$ . Thus the only two solutions to this equation are  $x = 1$  and  $x = -1$ .

If one has problems seeing that the only two solutions are 1 and  $-1$ , you can continue the algebra and factor the above equation as follows:

$$x^4 - 1 = 0$$

$$(x^2 + 1)(x^2 - 1) = 0$$

$$(x^2 + 1)(x - 1)(x + 1) = 0$$

Where  $x^2 + 1$  yields no real solutions, so the only solutions are given by  $x = 1$  and  $x = -1$ .

Alternatively, one may simply take the answers and plug them into the problem. For example, using Choice A,  $x = -2$ , one finds that  $f(x) = f(-2) = (-2)^2 + 1 = 5$ . Using the same value for  $x$ , one finds that  $\frac{1}{x} = -\frac{1}{2}$ , which gives

$f\left(\frac{1}{x}\right) = f\left(-\frac{1}{2}\right) = \left(-\frac{1}{2}\right)^2 + 1 = \frac{5}{4}$ . Since  $\frac{5}{4}$  is not equal to 5, we know that  $f(x) \neq f\left(\frac{1}{x}\right)$  when  $x = -2$ . The same logic can be used to test each of the Choices, and only  $x = 1$  and  $x = -1$  (Choices B and E) satisfy the equality.

2. **B, C, and F:** The cubic expression factors into  $x$  times a quadratic expression:  $x(x^2 + 3x - 10)$ , which further factors into  $x(x + 5)(x - 2)$ . Thus  $x(x + 5)(x - 2) = 0$  and  $x = 0, -5$ , or  $2$ . Therefore, the sum of any two solutions for  $x$  could be any of:

$$0 + (-5) = -5$$

$$(-5) + 2 = -3$$

$$0 + 2 = 2$$

3. **C:** The equation that describes the relationship between  $S_N$  and  $S_{N-1}$  also describes the relationship between  $S_{N+1}$  and  $S_N$ . Therefore we can write  $S_{N+1} = \frac{2}{3}S_N - 4$ . Similarly, we can write  $S_{N+2} = \frac{2}{3}S_{N+1} - 4$ . Substituting for  $S_{N+1}$  in this equation, we get the following:

$$S_{N+2} = \frac{2}{3} \left( \frac{2}{3}S_N - 4 \right) - 4$$

Solving for  $S_N$  in terms of  $S_{N+2}$ , we get:

$$S_{N+2} = \frac{4}{9}S_N - \frac{8}{3} - 4$$

$$\frac{4}{9}S_N = S_{N+2} + \frac{8}{3} + 4 = S_{N+2} + \frac{20}{3}$$

$$S_N = \frac{9}{4}S_{N+2} + 15$$

This equals Choice C.

4. **A and B:** To gain some insight, we might first look at a few representative cases.

Case 1: Both solutions are positive. Example:  $(x - 1)(x - 2) = 0$  or  $x^2 - 3x + 2 = 0$ .

Case 2: Both solutions are negative. Example:  $(x + 1)(x + 2) = 0$  or  $x^2 + 3x + 2 = 0$

Case 3: One solution is positive, the other is negative. Example:  $(x + 1)(x - 2) = 0$  or  $x^2 - x - 2 = 0$ .

These examples show that the constant term at the end is positive whenever the two solutions are of the same sign. However, in the given equation, the constant equals  $b$ , which is less than zero. Thus the two solutions must be of opposite signs, so Choice A is correct. We can also see that the constant term equals the product of the two solutions. In this case, that product is negative, so Choice C is incorrect.

Finally, the coefficient of the  $x$  term (i.e., the number that multiplies  $x$  in the given equation) is the *negative* of the sum of the two solutions. For example, in Case 1, the solutions are  $+1$  and  $+2$ , which sum to  $+3$ , but the coefficient of  $x$  is  $-3$ . In the given equation, the coefficient of  $x$  equals  $-a$ , which is negative. Thus Choice B is correct: the sum of the two solutions must be positive.

5. **C:** First eliminate the fraction by multiplying both sides by  $(1 - 2s)$ :

$$\begin{aligned} r(1 - 2s) &= 3s + 1 \\ r - 2sr &= 3s + 1 \end{aligned}$$

Next, since we are solving for  $s$ , we must collect  $s$  terms on one side:  $r - 1 = 3s + 2rs$ . Factor out  $s$  in order to isolate it:  $r - 1 = s(3 + 2r)$ . Finally, divide by  $(3 + 2r)$  to arrive at  $s = \frac{r-1}{3+2r}$ . There is an alternative to this algebraic

approach: picking numbers. Suppose we let  $s = 2$ . (In general, we want to avoid choosing 0 or 1 for variables, because those values can lead to unusual results and often similar results across the Choices.) For that value of  $s$ , we find that

$r = \frac{7}{(1-4)} = -\frac{7}{3}$ . We would then substitute this value of  $r$  into each of the Choices to determine which one gives us

$s = 2$ . As can be seen, in this case the calculation will be rather complicated, which may cost a fair amount of time in the solution process.

6. **B:** Expand Quantity A and subtract that quantity from both quantities in order to obtain a full quadratic expression in Quantity B:

$$\begin{array}{r} 4x - x^2 \\ 0 \end{array} \qquad \begin{array}{r} 6 \\ x^2 - 4x + 6 \end{array}$$

At this point, we can try to factor the resulting quadratic, but no simple factoring is apparent. The next option is to “complete the square,” which is to manipulate the quadratic in Quantity B so that it includes the square of an expression:

$$\begin{array}{r} 0 \\ 0 \end{array} \qquad \begin{array}{r} (x^2 - 4x + 4) + 2 \\ (x - 2)^2 + 2 \end{array}$$

As we can see, no matter what value we pick for  $x$ , the expression in Quantity B will never be less than 2 (because the squared term can never be negative). Thus **Quantity B is greater**.

Another approach would be to test various values for  $x$ . For instance, starting from  $x = 0$  and going up one integer at a time, we would see that  $x(4 - x)$  increases until it reaches a maximum value of 4 (when  $x = 2$ ), and then decreases again, indicating that it will always be less than 6. (To verify this, we can test  $x = 1.5$  and  $x = 2.5$  and demonstrate that the results are less than 4.)

A final option (which requires some insight into the graph of a quadratic function) is to recognize that the value of  $x$  for which the quadratic expression will be at an extreme (maximum or minimum) will be exactly halfway between the two roots, or solutions, of the quadratic. In this case, the roots of  $x(4 - x) = 0$  are  $x = 0$  and  $x = 4$ . Therefore, the extreme value is obtained when  $x = 2$ :  $2 \times (4 - 2) = 4$ , which is less than 6.

7. **B:** The given inequality can also be written as follows:  $-10 \leq 2n + 7 \leq 10$ . Subtracting 7 from each term (*including* the middle term) yields  $-17 \leq 2n \leq 3$ . Finally, dividing all 3 terms by 2, we obtain  $-8.5 \leq n \leq 1.5$ . This is a range of 10. However, we must remember that  $n$  has to be an integer. Therefore, the largest possible value of  $n$  is 1, and the smallest possible value of  $n$  is  $-8$ :

$$1 - (-8) = 9 \qquad 10$$

**Quantity B is greater.**

8. **A:** Manipulate the given inequality to get the  $s$  and  $t$  terms on one side of the inequality. In so doing, we can recognize the left-hand side of the inequality as one of the “special products”:

$$\begin{array}{l} s^2 + t^2 + 2st < 1 \\ (s + t)^2 < 1 \end{array}$$

If the square of  $(s + t)$  is less than 1, then  $(s + t)$  itself must be between  $-1$  and  $1$ :  $-1 < s + t < 1$ . Subtracting  $s$  from all 3 terms yields:  $-1 - s < t < 1 - s$ . Therefore  $t$  must be less than  $1 - s$ , and **Quantity A is greater**.

9. **C:** Calculate the first few terms of the sequence using the definition  $a_n = -a_{n-1} + 1$ :

$$a_2 = -a_1 + 1 = -2 + 1 = -1$$

$$a_3 = -a_2 + 1 = -(-1) + 1 = 1 + 1 = 2$$

We can see that the sequence will now settle into a constant pattern: each pair of numbers will be 2 (when the item index is odd) and  $-1$  (when the item index is even), with the sum of each pair equaling 1. There are 49 pairs in the first 98 terms, so the sum of the first 98 terms is 49. We can find the sum of the first 99 terms by adding the 99th term, which will be 2. Thus the sum of the first 99 terms is  $49 + 2 = 51$ .

10. **D:** One approach is to do the problem algebraically. The amount by which the purchase price exceeds  $p$  dollars is given by  $(x - p)$ . The shipping cost will equal the fixed cost of  $s$  dollars, plus 5% of this excess amount:  $s + 0.05(x - p)$ .

Alternatively, we could pick numbers and calculate a target value. Suppose  $s = 3$ ,  $p = 5$ , and  $x = 7$ . The shipping charges should equal \$3 plus 5% of the difference of \$7 and \$5, which is \$0.10. The target value is therefore \$3.10. Substituting our values for  $s$ ,  $p$  and  $x$  into the answer choices indicates that the expression in Choice D is correct.

11. **E:** We can set up a table to track the progress of the game.

Round	Caleb's marbles	Dan's marbles
Start	$4C$	$4D$
After 1st (Caleb wins)	$4C + \frac{4D}{2} = 4C + 2D$	$\frac{4D}{2} = 2D$
After 2nd (Dan wins)	$\frac{4C + 2D}{2} = 2C + D$	$2D + (2C + D) = 3D + 2C$

Thus **Choice E is the correct answer.**

We could, alternatively, pick numbers for  $C$  and  $D$  and track the progress of the game and then test each of the Choices to see which leads to the correct answer.

12. **D:** The functional relationship can be rewritten as  $y = 2|x - 4| + 1$ . The “notch” of the absolute value function will be located at the value of  $x$  for which the absolute value reaches the minimum possible value of zero. That will occur when  $x = 4$ . The value of  $y$  will then equal  $2|0| + 1 = 1$ . Also, when  $x = 0$ ,  $y$  will equal  $2|-4| + 1 = 9$ . This relationship is depicted in Choice D.

13. **4:** We can pick some numbers to make the problem easier. With the given information, the general formula for a diving board's stiffness is  $S = k \frac{T^3}{L^3}$ , where  $T$  is thickness,  $L$  is length and  $k$  is some constant. Suppose diving board  $A$

has thickness equal to 3 and length equal to 2. Then, its stiffness would equal  $k \frac{3^3}{2^3} = \frac{27}{8}k$ .

To simplify matters yet further, suppose  $k = 1$  (normally we would not use 1 when picking numbers, but because  $k$  is not relevant for solving the problem—it will cancel out when we do the math—we pick 1 for simplicity). The stiffness of diving board  $A$  is then equal to  $\frac{27}{8}$ .

We are told that diving board  $B$  is half the length of diving board  $A$ , and also has  $\frac{1}{8}$  the stiffness, of diving board  $A$ .

This means that the length of diving board  $B$  is 1 and its stiffness equals  $\frac{27}{8} \times \frac{1}{8} = \frac{27}{64}$ . Let us denote the thickness of diving board  $B$  with  $T$ . We can then write (again assuming  $k = 1$  for simplicity, again noting that the same value of  $k$  must apply to both diving boards because they are equal in all other respects):

$$(1) \frac{T^3}{1^3} = S = \frac{27}{64}$$

From this, we can determine that  $T^3 = \frac{27}{64} = \frac{3^3}{4^3}$  and  $T = \frac{3}{4}$ . The ratio of the thickness of diving board  $A$  to that of

diving board  $B$  must therefore equal  $\frac{3}{3/4} = 4$ .

14. **A:** We can try to factor the quadratic given in the problem, but no simple factoring is apparent. The next option is to “complete the square,” which is to manipulate the quadratic in Quantity A so that it includes the square of an expression.

$$\begin{array}{r} 5(b^2 - 2b) + 7 \\ 5(b^2 - 2b + 1) + 7 - 5(1) \\ 5(b - 1)^2 + 2 \end{array} \qquad \begin{array}{l} b \\ b \\ b \end{array}$$

It's clearer to see the answer if we subtract  $b$  and 2 from both sides next:

$$5(b - 1)^2 - b \qquad -2$$

The minimum value for the expression in Quantity A is  $-1$  when  $b = 1$ . Clearly, as  $b$  moves farther away from 1 in the positive direction, eventually the term  $5(b - 1)^2$  will rise faster than  $-b$  falls. And as  $b$  falls,  $-b$  will rise, so both terms in Quantity A will increase. Therefore, we only need to test a few values just larger than  $b = 1$  to see what happens to Quantity A (it will be useful to use the Calculator here):



$b$	$5(b - 1)^2 - b$	$-2$
1	-1	-2
1.01	-1.0095	-2
1.05	-1.0375	-2
1.1	-1.05	-2
1.11	-1.0495	-2

Therefore the minimum for Quantity A appears to be approximately  $-1.05$  and Quantity A will always be larger than Quantity B. (Indeed, the minimum for Quantity A occurs when  $b = 1.1$ .)

15. **C:** The only types of lawyers listed in the graph who practice litigation are Criminal Litigation and Civil Litigation lawyers. The percent of the lawyers who practice litigation is thus represented by  $x^2 + (x + 1)$ , and the percent of lawyers who practice Corporate law is 21%. (For the purposes of this problem we can ignore “number” of lawyers vs. “percent”, because the problem specifies that the percentages represented are exact.)

Because all the pieces of the circle graph must sum to 100%, we can write an equation and solve for  $x$ , starting with the upper-left segment and working clockwise:

$$21 + x^2 + (x + 1) + 16 + 22 + 17 + x = 100$$

$$x^2 + 2x + 76 = 100$$

$$x^2 + 2x - 24 = 0$$

$$(x + 6)(x - 4) = 0 \quad \rightarrow \quad x = 4 \text{ or } -6$$

Since a circle graph cannot contain a “negative” segment,  $x$  must equal 4. Therefore the percentage of the organization that works in litigation equals  $4^2 + (4 + 1) = 21$ , which is equal to the percentage that works in Corporate law. **The two quantities are equal.**

16. **A:** The first step is to isolate the absolute value expression:  $|2z| - 1 \geq 2$ , so  $|2z| \geq 3$ . Therefore  $2z \leq -3$  or  $2z \geq 3$ . Dividing both inequalities by 2, we get  $z \leq -1.5$  or  $z \geq 1.5$ . Only Choice A displays a graph for which the relevant range correctly does not include  $-1$ ,  $0$ , or  $1$ , and includes values above  $1$  and below  $-1$ .

17. **E:** The efficient approach to this problem is to recognize that this problem can be solved using a variant of the difference of squares special product:  $(a + b)(a - b) = a^2 - b^2$ . The distinction is that each of the exponents in this expression is halved in this problem (remember,  $x^{1/2} = \sqrt{x}$ ). Thus we can use:

$$(\sqrt{a} + \sqrt{b})(\sqrt{a} - \sqrt{b}) = a - b = 16$$

Since the first expression equals 8, we know that the second expression must equal  $\frac{16}{8} = 2$ .

Next, we can use the two equations containing square root expressions, and eliminate the  $\sqrt{b}$  terms by adding the two equations together:

$$\begin{array}{r} \sqrt{a} + \sqrt{b} = 8 \\ + \sqrt{a} - \sqrt{b} = 2 \\ \hline 2\sqrt{a} = 10 \end{array}$$

Therefore  $\sqrt{a} = 5$  and  $a = 25$ . Plugging this into the first equation, we get  $b = 9$  and  $ab = 225$ . Thus,  $\sqrt{ab} = 15$ .

Note that solving this question is much more difficult if the special product is not employed—one would have to first isolate one of the radicals, square both sides, employ substitution, isolate the radical again, square both sides, etc.

18. **B:** From the original equation, we can cross-multiply to arrive at:

$$(d)(d-2)\frac{2}{d} = \frac{2-d}{d-2}(d)(d-2)$$

$$2d - 4 = 2d - d^2$$

$$-4 = -d^2$$

$$d^2 = 4$$

It would appear at first glance that  $d$  could equal 2 or  $-2$ . However, remember that in the original equation,  $(d-2)$  appeared in a denominator. Therefore, 2 is not a solution, as it would result in a 0 appearing in a denominator, which is undefined (actually, indeterminate, as the numerator would also equal 0).

Only  $-2$  is a possible solution to the equation, and **Quantity B is therefore greater.**

19. **E and F:** Since  $a$  is not the square of an integer, its square root cannot possibly be the square of an integer (in fact, the square root of  $a$  cannot even be an integer itself, since  $a$  is not a perfect square). This rules out Choice A.

Choices B and C can be eliminated by the following logic: if  $a$  is greater than 1,  $a^2$  will be at least 4. Additionally since  $a$  is an integer,  $a^2$  will be a perfect square. There are no different perfect squares which are one unit apart (other than 0 and 1, and  $a > 1$ ), so  $a^2 + 1$  and  $a^2 - 1$  cannot possibly be perfect squares (they are each one unit away from a perfect square).

Choice D can be eliminated for a similar reason. If  $a = 2$ , then  $a^2 = 4$ , and the nearest lower perfect square is 1, 3 units away (3 is larger than 2). If  $a = 3$ , then  $a^2 = 9$ , and the nearest lower perfect square is 4, 5 units away (5 is larger than 3). If  $a = 4$ , then  $a^2 = 16$ , and the nearest lower perfect square is 9, 7 units away (7 is larger than 2). This pattern shows that subtracting  $a$  from  $a^2$  will result in a number somewhere in between  $a^2$ , a perfect square, and the next lower perfect square, which is  $(a-1)^2$ .

Choice E *must* be a perfect square, because the expression can be factored as  $(a-1)^2$ . Since  $a$  is an integer,  $a-1$  is an integer and  $(a-1)^2$  is a perfect square.

Finally, Choice F can be a perfect square whenever  $a$  is equal to half of a perfect square. For example, if  $a = 2$  or 8, then  $2a = 4$  or 16, respectively—both of which are perfect squares.

20. **56.3:** If  $c$  decreases by 20%, then the right-hand side of the equation changes by a factor of 0.64. To come to this conclusion, create a new variable,  $B$ , to represent the new value of  $b$  after the decrease in  $c$ :

$$a = b \times c^2 = B \times (c - 0.2c)^2 = B \times (0.8c)^2 = 0.64Bc^2$$

The ratio of  $B$  to  $b$  is thus:

$$bc^2 = 0.64Bc^2$$

$$\frac{B}{b} = \frac{1}{0.64} = 1.5625$$



Therefore  $b$  must change by a factor of 1.5625, or a 56.25% increase. Rounded to the nearest 0.1 percentage point, the percent change in  $b$  will be 56.3.