

1,014 Practice Questions for the New GRE®

Neill Seltzer
and the Staff of The Princeton Review

PrincetonReview.com



Random House, Inc. New York

Editorial

Seamus Mullarkey, Editorial Director
Laura Braswell, Senior Editor
Selena Coppock, Editor
Heather Brady, Editor

Random House Publishing Team
Tom Russell, Publisher
Nicole Benhabib, Publishing Manager
Elham Shahabat, Publishing Assistant
Ellen L. Reed, Production Manager
Alison Stoltzfus, Associate Managing Editor

The Princeton Review, Inc.
111 Speen Street, Suite 550
Framingham, MA 01701
E-mail: editorialsupport@review.com

Copyright © 2011 by The Princeton Review, Inc.

All rights reserved. Published in the United States by Random House, Inc., New York, and in Canada by Random House of Canada Limited, Toronto.

All questions in the book were created by the authors.

The Princeton Review is not affiliated with Princeton University.

eISBN: 978-0-375-42755-8
ISSN: 1943-4855

Editor: Liz Rutzel
Production Editor: Meave Shelton
Production Coordinators: Mary Kinzel, Deborah Silvestrini, and Ryan Tozzi
Illustrations by: The Production Department of The Princeton Review

v3.1

Acknowledgments

The following people deserve thanks for their help with this book: Lauren Akamine, Jonathan Arak, Forrest Bankston, Maralyssa Bann, Laura Braswell, Adam Cadre, Ed Carroll, Vanessa Coggshall, Joe Consiglio, Cynthia Cowan, Adam Davis, Cathy Evans, John Fulmer, Peter Hanink, Christopher Hinkle, Dara Hogue, Karen Hoover, Kim Howie, Jary Juliano, Kimberly Kendal, John Kim, Stephen Klosterman, Anna Konstantatos, Rebecca Lessem, Sionainn Marcoux, Joan Martin, Melanie Martin, John Massari, Mike Matera, Lisa Mayo, Seamus Mullarkey, Aaron Murray, Andrew Nynka, Abolaji Ogunshola, Jerome O'Neill, Emma Parker, Emillie Parrish, Adam Perry, Doug Pierce, Nicole-Henriett Pirmie, Krista Prouty, Curtis Retherford, Debbi Reynolds, Lisa Rothstein, Liz Rutzel, Meave Shelton, David Stoll, Phil Thomas, Scott Thompson, Kerry Thornton, Shawn Waugh, David Weiskopf, Jonathan Weitzell, Sarah Woodruff, and David Zharkovsky.

A special thanks to Neill Seltzer for conceptualizing this book from start to finish, and to Graham Sultan for helping those conceptions become a reality.

A very special thanks to Adam Robinson, who conceived of and perfected the Joe Bloggs approach to standardized tests and many of the other successful techniques used by The Princeton Review.

Contents

Cover
Title Page
Copyright
Acknowledgments
Introduction

Diagnostic Test

Math
Verbal
Answers & Explanations

The Verbal Section

Text Completions
Drill 1
Drill 2
Drill 3
Drill 4
Drill 5
Drill 6
Drill 7
Answers & Explanations

Reading Comprehension
Drill 1
Drill 2
Drill 3
Drill 4
Drill 5
Drill 6
Answers & Explanations

Sentence Equivalence
Drill 1
Drill 2
Drill 3
Drill 4
Drill 5
Drill 6
Drill 7
Answers & Explanations

The Math Section

Plugging In & PITA
Drill 1
Drill 2
Drill 3
Drill 4
Answers & Explanations

PITA and Hidden Plug-In Drill

Drill 1

Drill 2

Drill 3

Answers & Explanations

Number Properties

Drill 1

Drill 2

Drill 3

Drill 4

Answers & Explanations

Fractions, Decimals, and Percentages

Drill 1

Drill 2

Drill 3

Drill 4

Answers & Explanations

Ratios and Proportions

Drill 1

Drill 2

Answers & Explanations

Exponents and Square Roots

Drill 1

Drill 2

Drill 3

Drill 4

Drill 5

Answers & Explanations

Lines and Angles

Drill 1

Drill 2

Answers & Explanations

Triangles

Drill 1

Drill 2

Drill 3

Answers & Explanations

Circles

Drill 1

Drill 2

Answers & Explanations

3D Figures

Drill 1

Drill 2

Answers & Explanations

Charts and Graphs

Drill 1

Drill 2

Drill 3

Drill 4

Answers & Explanations

Linear Equations and Inequalities

Drill 1

Drill 2

Answers & Explanations

Quadratic Equations

Drill 1

Drill 2

Answers & Explanations

Probability, Rates, and Statistics

Drill 1

Drill 2

Drill 3

Drill 4

Answers & Explanations

Groups, Sequences, and Functions

Drill 1

Drill 2

Answers & Explanations

Combinations and Permutations

Drill 1

Drill 2

Answers & Explanations

Coordinate Geometry

Drill 1

Drill 2

Answers & Explanations

Essays

Issue Essay Drill

Argument Essay Drill



Introduction

SO YOU'VE DECIDED TO GO TO GRAD SCHOOL...

Much like the SAT that you probably took to get into college, the GRE—or the Graduate Record Exam, as it is officially known—is required for admissions by many graduate programs. GRE test takers include future engineers, historians, philosophers, psychologists, nurses, even veterinarians. In short, the GRE is used by just about any graduate program that is not medical school, law school, or business school. It may seem odd that a student who is applying for an advanced degree in architecture must take the same exam as a student applying for a degree in comparative literature. In many respects, it is. Because a wide variety of graduate programs rely upon the GRE rather than their own proprietary exam, GRE results are used in a wide variety of ways.

Some programs simply have a minimum combined score that all applicants must achieve. Other programs, such as a creative writing program, care far more about the Verbal score than they do about the Math score. One would think that engineering programs would care more about the Math score, as some do, but most engineering applicants score in the very highest percentiles on the GRE quantitative section and therefore Verbal scores, not Math, become a more effective tool for comparing one candidate to another.

If you are frustrated that the skills you have to dust off and polish for the GRE bear little resemblance to the subjects you will be studying in grad school, remember three things. First, the GRE is not a content test. It does not test a body of knowledge, like U.S. history or French. It is designed to test a very specific way of thinking. Second, taking the GRE is a skill, and like any other skill, it can be learned. That is what this book and *Cracking the New GRE, 2012 Edition* are all about. With diligence and practice you can learn everything you need to know for the GRE, and you can do it in a surprisingly short period of time. Far less time, in fact, than it took you to learn physiology, Renaissance poetry, or whichever subject you plan to pursue in your graduate studies. The last thing to remember is that the GRE is only one factor of many that will be considered for admissions, and it is often the easiest to change.

The first task in preparing for the GRE is doing your graduate school research.

There is no such thing as a good GRE score or a bad GRE score. There is only the score you have and the score you need to get where you want to go. The gap between the two represents the amount of work you will have to do in the meantime. If you need an additional 50 points (on the old scale), that shouldn't be too difficult to achieve. Polish up your vocabulary, master the pacing of the exam, and take some practice tests and you should do fine. If you need another 100 points (on the old scale), that will take some more work. You'll need more vocab, you'll need to identify and address your gaps on the Quantitative section and you'll need more practice. If you can push yourself to do that on your own, this book and access to a few practice tests should be all you need. If you need more than 100 points (on the old scale), or you aren't likely to put in the time on your own, you will need a course or a tutor. It all starts with the research. Once you know the score you have and the score you need, you will know how much time you need to put in to prepare for the real test.

How schools weight the scores, assuming they can even answer this question, will differ not only from school to school, but even from student to student. Schools may use GRE scores to validate the verbal abilities of international students with really fantastic essays. GRE scores may be used in lieu of work experience for applicants who are only a year or two out of undergrad, or as a more recent snapshot for adult students returning to school after a decade or so. Mostly they are just there so that schools have an apples-to-apples comparison of applicants with a wildly divergent range of undergrad, work, and life experiences. Also, most applicants are pretty qualified. Often the scores are there as an easy way to narrow down the pool.

How your program uses your scores will determine quite a bit about how you prepare for the test. The following is a list of questions to ask when you call up your target school.

How Much Do GRE Scores Count?

Schools generally do a pretty good job of telling applicants what is required (application, recommendation, essays, portfolios, test scores, transcripts), but how one factor is weighed against another is a murky science. Typically a GPA or current work experience will weigh far more heavily than a GRE score. On the other hand, if your GPA is on the low side, you will want your GRE scores to be as high as possible to prove that you can do the work.

What Is Your Acceptance Rate?

In other words, competitive is your program? A highly competitive program may not weigh GRE scores very heavily, but if they are rejecting 60 percent of their applicants, every number they see will matter.

What Do You Do With Multiple Scores?

Some schools look only at the most recent; some will combine, but most prefer to use the highest. The CAT test is not like any other test most students have ever taken. The first time people take it is often not their best. The second time, however, students are more comfortable, and scores tend to jump up—even if it is only a week or two later. Plan on taking the test twice.

Do You Use, Look At, or Care About My Analytic Essay Scores?

If schools don't, and most don't, you won't have to spend valuable time practicing this portion of the test.

Do You Care About My Math/Verbal Score?

This is for programs like engineering or English lit, which are clearly weighted toward one side of the test or another. It would be great news if you found out that you could blow off the Math section altogether, no?

Do You Have a Cut-Off Score, and/or What Were the Average Scores or Percentiles for Last Year's Incoming Class?

Do you fall below the average or above it? Larger programs may have and publish these numbers; smaller ones may not.

This will tell you a lot about how much work you have to put in between now and test day.

It is in a school's interest to have a well-informed, serious applicant. Student who drop out of grad school because they've chosen the wrong career path, can't manage the workload, don't like the program, or simply found that the program in particular (or grad school in general) was not what they'd hoped it would be, have wasted both the school's time and money as well as their own. In many ways, the application process is all about identifying those students who will stay in the field and go on to rain glory down upon their alma mater. Students who don't fit that description are far more likely to drop out of the program. Those students and that tuition are hard to replace (advanced standing and executive programs are often a way for schools to take advantage of excess capacity freed up by vacating students).

In short, don't be afraid to pick up the phone and start your research. The more you know, the easier the process becomes, and the more likely it is that you get accepted—and the more likely it is that you make a wise choice with this investment of time (years), money (hundreds of thousands), and opportunity costs (how far would those same two years get you if you stayed where you are?). This is important.

If you have done your research and you know exactly where you want to go and why, then the GRE simply becomes a small hurdle that you must cross on your way. The GRE is an eminently surmountable hurdle. If you are not committed to the end game, the GRE may become a barrier rather than just a hurdle. If you are not clear on why you are going through this very long, expensive, and onerous process, then going out for drinks with friends on a Thursday night may seem far more worth while than sitting down to take another practice test, and therein lies the problem.

Getting serious about the research is the first step towards getting serious GRE scores.

THE TEST—OVERVIEW

You will receive a Math score, a Verbal score and an Analytic Writing score. These correspond to the three types of sections you will see on the test. Section by section, here's how the test breaks down:

Section	Number of Questions	Allotted Time
Analytic Writing (one section with two separately timed essays)	One "Analyze an Issue" essay and one "Analyze an Argument" essay	30 minutes per essay
Break		10 minutes
Verbal Reasoning (×2)	20 Questions	30 minute per section
Quantitative Reasoning (×2)	20 Questions	35 minutes per section
Experimental	20 Questions	30/35 minutes
Research	Varies	Varies

(Click [here](#) to view a larger image.)

Your essay sections will always come first. These are two back-to-back essays, each 30 minutes. After the essays you will have one of your first multiple-choice sections, and then you get your one and only proper break. Most students will see five multi-question sections, either two verbal and three math or three verbal and two math. Two Verbal sections and two Math sections will always count. The extra section is experimental. It may be math or verbal, it will look just like the other sections, but it will not count. These five sections, including the experimental, could occur in any order. There is no way to know which section is experimental. You will have a one minute break between each of these sections.

Occasionally they will give you a research section in place of the experimental section. If so, it will come last; they will identify it as a research section and will tell you that it does not count. If you see one of these, your test is over and your first four multi-question sections counted.

The Test Experience

The total testing time is close to four hours. It is a long four hours full of intense concentration. For those who are not prepared it can also be full of lots of stress, and the atmosphere in the testing centers is not exactly designed to put you at ease.

When you are taking practice tests make sure to complete all sections, even the essays, because stamina is an issue. Frequently students will focus just on areas of weakness or blow off the essay because they're not concerned about the essay score. This is a mistake. Knowing how your brain works after two to three hours of close concentration is big part of being prepared.

The testing center can be an intimidating place. You will be asked to show ID when you come in. You will be issued a locker where you can store your belongings, since you cannot bring anything with you into the test center. Then you will be asked to fill out a questionnaire and a legal disclaimer stating that you are who you say you are and that your reasons for taking the test are on the up and up (no taking it just for fun!). The test center caters to people taking a wide variety of tests, including TOEFL tests, citizenship tests, and others. This means that you will be sitting in a very plain institutional waiting room with a bunch of other fidgety, stressed-out people until you are called to the testing

room.

In the testing room you will be issued a cubical with a computer, six sheets of scratch paper, two pencils, and a set of headphones. Tests such as the TOEFL have an audible component, but the head phones are also used to block out the noises from the cubicles around you. This is usually a good thing, since you will hear people smacking their foreheads, reading out loud, cursing, crying, and occasionally laughing. The fellow testing next to you may be watching his future dissolve before his very eyes. He may find the fact that you are humming to yourself, chuckling, and generally having a swell time—since you are so well prepared—a bit unnerving. That’s why they have headphones.

In the beginning of the test you will be given a tutorial on how to use the computer (scrolling, clicking with the mouse, accepting answers, etc.). We certainly hope that you feel prepared enough to skip this section (everyone is so nervous that they might miss something—although, in truth, almost no one does). If you have taken a few practice tests, you know what to do. Save yourself the extra eyeball time and skip the section.

The first section you will see is the 30-minute Analysis of an Issue essay. You will be given a choice between two issue topics. The clock starts as soon as the two topics appear on screen. A complete list of the issue topics can be found on ETS’s website. The tester has a basic word-processing function that will allow you to cut, paste, erase, and scroll. It does not have a spell-checker, but spelling is not tested on the GRE.

The second section is the 30-minute Analysis of an Argument essay. In this section, you cannot choose your argument. A complete list of potential arguments can be found on the ETS website in the same place. The two essays are considered your first section. You will then get two multiple-choice sections; they could be math and verbal or verbal, in any order. After your third section, you will be offered an optional 10-minute break. Use it to flap your arms a bit to get your blood flowing or rest your eyeballs. You could use it to go to the bathroom, but you’d have to be quick. Take as much time as you need to refresh yourself, but the more time you take the longer you’ll be stuck in your cubical. Technically you are not allowed to use your scratch paper during untimed sections, but this is not always enforced.

Most students will have five multiple-choice sections. All five will look like typical Verbal or Math sections but only two of the three will count. The uncounted section is experimental. One Math and one Verbal section will count for sure. The experimental section may be either math or verbal and may occur anywhere between sections two and six. Occasionally ETS will identify the experimental section. They typically do this when they have really strange stuff to test and don’t want to entirely freak out the test takers. For the most part, the experimental section is used to gather data on new questions so that they can be added to the general pool of scored questions. In other words, you are paying ETS to do their R&D for them and you are doing it when you are at your most stressed and your time is the most valuable. Sorry.

ETS may also add a “research” section. If they do this, it will come after the multiple-choice sections and they will attempt to bribe you with an infinitesimally small chance at winning a pathetically small scholarship (\$500) toward your grad school tuition. Unless you are a particularly generous soul, don’t bother.

After you have taken the scored portion of the exam, you will be given the opportunity to cancel your scores. After four hours, everyone tends to believe that they did worse than they actually did. Unless you passed out mid section, left five to ten questions blank, or started hallucinating while on the clock, there is not much to be gained from canceling the scores. If you cancel, you will never know how you did. Your test fee is non-refundable. Your record will reflect that you took the test on this day but that you cancelled your scores. At this point you should know how your programs will deal with multiple scores. Unless you have a really compelling reason to believe that your scores were a disaster, accept them.

In addition to the dubious honor of contributing to ETS’s research and development, your registration fee also buys you score reporting for up to four schools. Normally, if you wish to have scores sent to school, ETS will charge you approximately \$15 per school. On test day, however, the first four schools are included. This will be the last section of your test. You might as well take advantage of it. Some students are reluctant to send scores to first-choice schools because they don’t yet know their scores. Send them anyway. If you are planning to apply to a particular school, they will see all of your prior scores, even if you take the test five times. If you don’t apply they’ll put the scores in a file and, after a year or two, they’ll throw them away. You have nothing to lose from sending out the scores. If you happen to know the school and department code for the schools of your choice, this part will go a bit faster. If not, no problem; you will have to negotiate a series of drop-down menus by state, school, and department.

You will have one minute between sections. You cannot skip questions, and you cannot go back to a question once you have entered and accepted an answer. Once you have completed the test, the computer will give you the option to accept your scores. Once you accept, they will show you your Math and Verbal scores only. Writing scores and percentiles will come about ten days later in the mail. You must turn in your scratch paper and collect your ID on your way out (and you have to leave the headphones there too).

It is a long and grueling process. The more you have prepared, the less stress you will feel on test day. You can walk out of the test center feeling elated that it’s over and good about your scores. Every math or verbal concept that you might see on the test is contained in this book. For the well-prepared student, there should be no surprises on test day. You should know precisely what your target score is and how to achieve it.

Scores

Before August of 2011 the GRE was scored on a 200–800 point scale, per section, in 10-point increments—much like the SAT. A student might receive a 650 on the Math section and a 590 on the Verbal, for example. When the test changed, it was imperative that ETS changed the score scale as well to avoid any confusion between old and new test scores. You can imagine what would happen if it stayed the same. Students would say that they got a 600 on the Math section, and admissions officers would never know if that was a 600 on the old test or the new one.

The GRE Revised General Test is scored on a 130–170 point scale in one-point increments. A student might get a 159 on the Math and a 158 on the Verbal. The new scale includes only 40 gradations between the highest possible score and the lowest, whereas the old test

ETS claims that the new test minimizes the perception of differences between scores that are really only separated by one or two gradations. That means that the difference between a 580 and a 600 seems much bigger than the difference between 148 and a 150. This doesn't give much credit to the intelligence of admissions professionals who understand the difference between a 1- and a 10-point scale, but they needed to change the scale anyway.

Essays, on the other hand, will continue to be scored on the same 1–6 point scale in half-point increments. Students will receive a single averaged essay score for both essays. Quarter point increments are rounded up.

RESOURCES

In addition to this book you have some other worthwhile resources to consider:

Power Prep—There is a new Power Prep sample test on the ETS website. It is not adaptive, but it does mimic the functionality and style of the new GRE Revised General Test.

Practicing to Take the GRE General Test, 10th Edition—This is another ETS publication. It contains seven full-length former pencil and paper exams. Essentially it is another large group of practice problems. There is little relationship between a pencil-and-paper score and a CAT score, but more practice items is always a good thing. It does not have the new question types (Text Completion, Sentence Equivalence, Numeric Entry, and All That Apply) represented, and you will need to ignore the old format questions, but much of the math in the Quantitative sections is relevant and useful for practice.

PrincetonReview.com contains one full-length, free GRE Revised General Test and a free online course demo. It also contains e-mail tips for test takers, and Word du Jour to help with your vocabulary.

Cracking the New GRE, 2012 Edition—While this book is primarily about providing additional practice items for each subject, Cracking the New GRE is like a full course in your hands. It contains all of the strategies, tips, and advice that have made The Princeton Review the best standardized test-preparation company in the world.

Verbal Workout for the New GRE—This book gives you everything you need to tackle the verbal portion of the GRE test. It includes hundreds of practice exercises to sharpen your skills, as well as the Hit Parade for the GRE, a list of the 300 vocabulary words that most frequently appear on the exam.

Math Workout for the New GRE—This book goes into greater depth on each of the key math skills you will need on the test and contains multiple drills for each skill you may encounter on test day.

Crash Course for the New GRE—This slim volume summarizes all of the major approaches. It is a great and focused review for those who are short on time.

HOW TO USE THIS BOOK

This book is all about building good test-taking habits, not about finding answers.

Over four hours of testing, your brain will get tired. When it gets tired, it will get sloppy. You might find yourself reading a question twice before it registers in your brain. You might start to skip small but key words, or you might find yourself staring at a problem for 30 seconds before you realize what you have to do. When you get tired you begin to do things by habit without really thinking about them actively. If your habits are good, they will help carry you even when your brain starts to check out. If you have not taken the time to create good test-taking habits, well, you just get sloppy. Sloppiness will kill your score.

The creation of habits requires repetition and that's where this book comes in. You have large groups of similar question types that you can do over and over again until you learn to instantly recognize the opportunity and respond correctly.

There is a finite quantity of GRE practice material on the market. It is entirely possible to burn through all of it without improving your score by as much as one point. In fact, you may end up further reinforcing bad habits rather than creating new good ones. This happens when you focus on finding answers to each individual question without looking for larger patterns, working to practice and refine your approach, or using the practice material as an opportunity to create good GRE habits. Use *Cracking the New GRE* and ETS's 10th Edition to establish your approach to different question types. Then work your way through this book to cement those approaches into an automatic habit. When you do this, time and large score fluctuations will cease to be an issue. There will be no such thing as having a good or bad day on test day. You will be in control and will have your scores right where you want them.

If you want to change your score, you must change the way you take the test.

Assessment

If you are under a time crunch or just need to shore up some weaknesses, this is your first step. Take the math and verbal assessment tests provided at the beginning of the book. Check your scores and find your areas of weakness. Pick two or three to focus on. The number of questions in a drill represents the frequency with which the question type shows up on most GRE Revised General Tests. Start with the high-frequency topics and focus on those first.

Practice

Each question type begins with a brief synopsis of the basic approach. Read these sections carefully. These approaches have been tried, tested, and refined by hundreds of test takers over the years. They are here because they work. They represent the good habits. How does the approach described by the book differ from your own? Can yours be improved?

Use *Cracking the New GRE* to work out your approach. Remember that the practice items don't count. No one will ever see how you did. Now is the time to take some risks and try out some different ways to solve these problems. Again, it's not about answers, it's about approach. Some of the new techniques may feel awkward at first, but they're there because they work. Stick with it.

Once you have found some patterns that work for you, move on to the drills in this book. Use your scratch paper, stick to your approach, and drill it until it becomes habit. By the time you are done, every time a question of that type pops up, your hand and your mind will know instinctively what to do, no matter how tired you get. This is powerful.

The One-Two Punch

If you are just starting your GRE prep, need more than 50–60 points, or don't yet have an approach, this book is not the place to start. This book is not for teaching. It is a workbook for practice and drilling. *Cracking the New GRE* will go into the test and the techniques in far more depth. It will break down the approach to each question in a step-by-step manner with plenty of examples. *Cracking the New GRE* is where you go to learn how to take the test; this is where you go to practice it.

THE TEST

The problem you're working on will be in the middle of the screen. If there is additional information, such as a chart or graph or passage, it will be on a split screen either above the question or to the left of it. If the entire chart(s) or passage or additional information does not fit on the split screen there will be a scroll bar.

Questions with only a single answer will have an oval selection field. To select an answer, just click on the oval. A question with the potential for multiple correct answers will have square answer fields. An X appears in the square when you select the answer choice. At the bottom of the screen, under the question, there may be some basic directions, such as "Click on your choice."

A read-out of the time remaining in the section will be displayed in the upper right corner. Next to it is a button that allows you to hide the time. No matter what, the time will return and will begin to blink on and off when you have five minutes remaining on a particular section. At the top-center the display will tell you which question number you are working on, out of the total number of questions. The top of the screen will also contain the following six buttons:

Exit Section: This button indicates that you are done with a particular section. Should you finish a section early, you can use this button to get to the next section. Once you've exited a section, however, you cannot return to it. Note that the two essays are considered a single section. If you use this button after your first essay, you will have skipped the second essay.

Review: This button brings up a review screen. The review screen will indicate which questions you've seen, which ones you've answered, and which ones you've marked. From the review screen you can return to the question you've just left, or you can highlight a particular question (once you've seen it) and Go To Question.

Mark: The mark button is just what it looks like. You may mark a question for whatever reason you choose. This does not answer the question. You may mark a question whether you've answered it or not. Marked questions will appear as marked on the review screen.

Help: The help button will drop you into the help tab for the particular question type you are working on. From there, there are three additional tabs. One gives you "Section Directions." This is an overview of the section, including the number of questions, the amount of time allotted, and a brief description of the function of ovals vs. boxes. The second is "General Directions" on timing and breaks, test information, and the repeater policy. The last additional tab is "Testing Tools." This is an overview of each of the buttons available to you during a section. Note that the help button will not stop the clock. The clock continues to run even if you are clicking around and reading directions.

Back/Next: These two buttons take you forward to the next question or back to the prior question. You can continue to click these as many times as you like until you get to the beginning or end of the section. If you return to a question you have answered, the question will display your answer.

We will talk more about strategies for pacing on the test and ways to use the mark and review buttons. You should never need the help button. Ideally you will be familiar enough with the functions of the test that you don't have to spend valuable test time reading directions.

How the New GRE Works

The new test is adaptive by section. Your score is determined by the number of questions you get right and their difficulty level. On the first Verbal section the test will give you a mix of medium questions. Based upon the percentage of questions you get right on that first section, the computer will select questions for the second section. The more you get right on the first section, the harder the questions you will see on the second section, but more potential points you could get.

Everything is determined by the number of questions you get right, not by the number of questions you answer. Accuracy, therefore, will always trump speed. It makes no sense to worry about the clock and to rush through a section if your accuracy suffers as a result.

Take the Easy Test First!

On the GRE, there are questions and there are questions. Some are a breeze, while others will have you tearing your hair out. The new GRE has been constructed so that you can answer questions in any order you like, and the questions you get on the second section will depend upon the number of questions you get right on the first section. You can maximize that number by doing the questions you like first! Remember that every question counts equally towards your score. As you work through a section, if you see a question you don't know how to answer, skip it. If you see one that looks as if it will take a long time, skip it. If you love geometry, but hate algebra, do all of the geometry questions first and leave the algebra questions for last.

Unless you are shooting for a 700 (on the old scale) or higher, you should NOT attempt to answer every single question.

As long as you are going to run out of time, you might as well run out of time on the questions you are least likely to get right. By leaving time-consuming and difficult questions for the end, you will be able to answer more questions overall and get more of them right. Do not mark questions you skip; we will use the mark function for something else. Just click "Next" and move on to the next question. The review screen will tell you which questions you have not answered.

Note: There is no guessing penalty on the GRE. They don't take points away for a wrong answer. When you get to the two-minute mark, therefore, stop what you're doing and bubble in any unanswered questions.

Answer Questions in Stages

Any time you practice for a test you end up getting a few wrong. Later, when reviewing these questions, you end up smacking your forehead and asking yourself, "What was I thinking?" Alternately, you may find a problem utterly impossible to solve the first time around, only to look at it later and realize that it was actually quite easy; you just misread the question or missed a key piece of information.

On a four-hour test, your brain is going to get tired. When your brain gets tired, you're going to make mistakes. Typically these mistakes consist of misreadings or simple calculation errors. A misread question or a calculation error will completely change the way you see the problem. Unfortunately, once you see a question wrong, it is almost impossible to see it correctly. As long as you stay with that question, you will continue to see it wrong every time. Meanwhile, the clock is ticking and you're not getting any closer to the answer. We call this "La La Land." Once you're in La La Land, it is very difficult to get out.

On the flip side, once you've spotted the error, solving the problem correctly requires only a moment. A question that bedeviled you for minutes at the end of a test may appear to be appallingly obvious when viewed in the comfort of a post-test review. The trick is to change the way you see the question while you still have the opportunity to fix it.

Step 1—Recognize La La Land.

Step 2—Distract your brain.

Step 3—See the problem with fresh eyes and fix it.

Step 1—Recognize La La Land. This is often the hardest part of the process. The more work you've put into a problem, the more difficult it is to walk away from it. Once you get off track on a problem, however, any additional work you invest in that problem is wasted effort. No problem on the GRE, if you understand what's being asked, should ever take more than a minute or two to solve. If you go over two minutes, you're off track. Get out. If you find yourself working too hard, or plowing through reams of calculations, you are off track. Get out.

Here are a few signs that you are in La La Land:

www.ztcprep.com
You find an answer, but it is not one of the choices they've given you.

- You have half a page of calculations, but are no closer to an answer.
- You've spent more than four minutes on a problem.
- Your hand is not moving.
- You're down to two answer choices, and you would swear on your life that both are correct.
- There is smoke coming out of your ears.
- You're beginning to wonder if they made a mistake when they wrote the question.

If you find yourself in any of these situations, you are in La La Land. Stop what you're doing and get out. You've got better things to do with your time than sitting around wrestling with this question.

Step 2—Distract your brain. When you find yourself faced with an immovable object, walk away. Think of it this way: You could spend four minutes on a question even when you know you're stuck, or you could walk away and spend those same four minutes on three other easier questions and get them all right. Why throw good minutes after bad? Whether they realize it or not, ETS has actually designed the test to facilitate this process. This is where the mark button comes into play. If you don't like a problem or don't know how to solve it, just skip it. If you start a problem and get stuck, mark it and move to the next question before you waste too much time. Do two other problems (three tops) and then return to the problem that was giving you trouble. We're fishing for that flash of insight here, given the chance to occur.

When you walk away from a problem, you're not walking away entirely; you're just parking it on the back burner. Your brain is still chewing on it, but it's processing in the background while you work on something else. Sometimes your best insights occur when your attention is pointed elsewhere. Walk away from a problem early and often. You want to always have questions to use to distract your brain. If you take the test in order, you will not have questions available at the tail end of a section. On some difficult problems you may walk away more than once. It is okay to take two or three runs at a hard problem.

Step 3—See the problem with fresh eyes and fix it. You use other problems to distract your brain so that you can see a troublesome problem with fresh eyes. You can help this process out by trying to read the question differently when you return to it. Use your finger on the screen to force yourself to read the problem word for word. Are there different ways to express the information? Can you use the answer choices to help? Can you paraphrase the answer choices as well? If the path to the right answer is not clear on a second viewing, walk away again. Why stick with a problem you don't know how to solve?

Scratch Paper

After pacing, the next most important global skill is the use of your scratch paper. On a regular test you can solve problems with a pencil right on the test page. On the GRE, you don't have that luxury. Remember that taking the GRE Revised General Test is a skill, and like any other skill it can be practiced and learned. Your physical habits as a test taker are as important as your mental ones. In fact, your physical habits will be used to reinforce your mental ones. Remember that the test is chock-full of tricks and answer choices designed to tempt the tired mind. If your hand is not moving it means that you are answering questions in your head. That is precisely what ETS wants because they have a million students a year testing out their tricks on the experimental section. They are extremely good at it. Your one head cannot beat a-million-students-a-year's worth of trial and error and refinement—but your hand can.

Your use of scratch paper can set you up to approach a question that you might not otherwise know how to approach, it can protect against careless errors, it can have a remarkable effect on efficiency, and, best of all, it can relieve an enormous amount of the mental stress that occurs during testing.

Tip #1—You can separate all GRE questions into two categories. The first category is for questions that you are supposed to get right. These questions are in your scoring range; you know the math or the vocabulary. Not only can you get these questions right but it is critical to your score that you do so. The second category is for questions that you're not supposed to get correct. They have been tested and proved to be hard; they have difficult vocabulary words and difficult math. Within this categorization, the techniques have two functions. The first is to ensure that the questions you are supposed to get right, you do get right. This is not to be dismissed lightly. Careless errors, especially in the first ten questions, will kill your score. Rushing through problems that seem easy will kill your score. The second function of the techniques is the use of Process of Elimination to ensure that any and all students will get correct a guaranteed percentage of even those questions that they are not supposed to get correct. Proper use of scratch paper ensures that techniques are happening and happening correctly.

Tip #2—On the Verbal section, the scratch paper has two primary functions. The first is to allow you to park your thinking on the page, to externalize it, to commit to it. If you are doing even an easy question in your head, you are really doing two jobs. The first is the work of solving the question. The second is the work of keeping track of which answer choices are still in and which ones are out. Not only is this mental multi-tasking extremely inefficient, it can also be quite stressful. Frankly, it's twice the work. By parking your thinking on the page, you efficiently remove wrong answers from consideration, identify your potential answer choices, and move on. You create clarity and organization. Both things lead to less stress, less mental effort, and ultimately less mental fatigue. Students who are doing the work in their heads will spend 20 percent of their time per question just looking at the screen, keeping track of what is in, out, or a maybe.

Tip #3—On the Math section there are a number of question types that provoke very specific set-ups on your scratch paper. Once you see the question types, before you have even fully read the question, you make your set-ups and start filling in information. When you have done this, you are halfway into the question, you have organized your thinking and approach, and you have set yourself up to succeed on the problem. All that remains is to fill in the numbers. This is stress-free living on the GRE. It all starts with the scratch paper.

Tip #4—On the Verbal, use your scratch paper as a place to park your thinking. Quickly evaluate each answer choice with a simple check for one that could work, an X for one that will not, an M or horizontal squiggle for a maybe, and a question mark for one you do not know. Once you have evaluated each answer choice, select from the ones which remain and move on.

Tip #5—Learn the set-ups for each type of question. Keep your page organized with space on one side for the question set-up and the other side for calculations. Once you have completed a question, draw a horizontal line across the page and start the next one in a clean space. Do your work on the page. If you get off track you will be able to find out why and where.

Tip #6—On the Verbal, do not be afraid to use the “Maybe” sign. Before you spend ten minutes scratching your head and trying to assess a difficult answer choice, give it the maybe. It is entirely possible, if not likely, that you will either eliminate the other four answer choices or find a much stronger one. You can always spend more time on an answer choice IF you have to, but you never want to spend more time THAN you have to.

VERBAL QUESTION TYPES

Text Completion—These used to be Sentence Completion, but now they’ve gotten longer, and you must work with each blank independently. Questions may have between one and five sentences and one to three blanks. A one-blank question will have five answer choices. A two- or three-blank question will have three choices per blank. You must select the correct word for each blank to get credit for the question.

Sentence Equivalence—These look like Sentence Completion questions but with one blank and six answer choices. You must select two answer choices from the six provided. The correct answers will each complete the sentence and keep the meaning the same.

Reading Comprehension—Reading Comp supplies you with a passage and then asks you questions about the information in the passage, the author’s intent, or the structure. There are three distinct question types that could occur here. They are:

- **Multiple Choice**—You must select one correct answer from five choices.
- **Select All That Apply**—These questions used to number three choices with roman numerals and you had to pick I, I, and II only, etc. Now you simply select the correct answer or answers from a group of three choices.
- **Select in Passage**—You will be asked to click on an actual sentence in the passage. You may click on one word to select the whole sentence. Only one sentence is correct. These will occur primarily on short passages. If they occur in a long passage, the question will specify a particular paragraph.

MATH QUESTION TYPES

Quantitative Comparison—Quant Comps, for short, give you information in two columns. Your job is to decide if the values in the two columns are the same, if one is larger, or if it is impossible to say. (Tip: If there are no variables in either column, eliminate answer choice D.)

Problem Solving—These are the typical five-answer, multiple-choice questions you probably remember from the SAT. You must correctly select one of the five answer choices to get credit. (Tip: They’ve given you the answers. One of them is correct. Use the answer choices to help answer the question.)

Select All That Apply—This is a new twist on the old multiple-choice question. In this case you may have three or up to eight answer choices, and one or more will be correct. You must select all of the correct answer choices to get credit. (Tip: The answer choices are generally in chronological order, so start in the middle and look to eliminate as many answer wrong choices as possible.)

Numeric Entry—Alas, these are not multiple choice. It is your job to come up with your own number and type it into the box provided. For fractions, you will be given two boxes and you must fill in the top and the bottom separately. (Tip: You don’t have to reduce your fractions. The computer reads 44/88 the same as 1/2, so save yourself a step.)

The Calculator

Yup, that’s right, the new GRE now provides an on-screen calculator. Like the calculator you might find on your computer, this one will add, subtract, multiply, divide, and find a square root. It also has a transfer number button that allows you to transfer the number on the calculator screen directly to the box on a Numeric Entry question. This button will be grayed out on a multiple-choice question.

Since we all use calculators in our daily life, it’s about time they provided one on the GRE. Certainly this should cut down on basic calculation errors and save a bit of time on questions that involve things like averages or percentages. The GRE, however, is not generally a test of your ability to do large calculations, nor is the calculator a replacement for your brain. The test makers will look for ways to test your analytic skills, often making the calculator an unnecessary temptation, or, at times, even a liability. Be particularly careful of questions that ask you to provide answers in a specific format. A question may ask you to provide an answer rounded to the nearest tenth, for example. If your calculator gives you an answer of 3.48, and you transfer that number, you will get the question wrong. Or a question may ask you for a percent and will have the percent symbol next to the answer box. In this case they are looking for a whole number. Depending upon how you solve the problem on your calculator, you may end up with an answer of .25 for 25%. If you enter the decimal, you will get the question wrong.

Here are a few tips for when to use and when not to use your calculator on the GRE:

Good Calculator

- Multiplying two- and three-digit numbers
- Finding percentages or averages
- Questions involving Order of Operations (The calculator will understand Order of Operations. If you type in $3 + 5 \times 6$, it will know to prioritize multiplication over addition, for example.)
- Questions that ask you to work with decimals

Bad Calculator

- Converting fractions to decimals in order to avoid working with fractions (better that you know the rules and are comfortable with

- Attempting to solve large exponents, square roots, or other calculation-heavy operations. There is almost always a faster way to do the problem.
- Questions involving adding or subtracting negative numbers if you're not sure of the rules.
- Charts problems with multiple questions. Write all information down on your scratch paper and label everything. Information you find on one problem might help on another. If you do everything on your calculator, you will have to recalculate.

Calculating

In general, ETS is not interested in testing your ability to do lots of calculations. In fact, they've even experimented with giving students on-screen calculators. They like to think that they are testing how well you think rather than how well you can calculate. Therefore, if you find yourself doing lots of calculating on a particular question, you are probably off track. Oftentimes you can calculate your way to the correct answer if necessary, but usually there is a better way. Your success depends upon how quickly and readily you can spot the opportunities.

Algebra is one math concept that shows up all over the test. There are dozens of different ways to ask an algebra question, some more obvious than others. The sooner you recognize it as an algebra question and make the correct set-up on your scratch paper, the better. This will buy you more time for the occasional question where you do get hung up. That is where this book comes in. The first ten algebra questions may look hard. By the time you've seen 60, however, you begin to see them all variations on a theme. When you can do that, you're ready.

Reading

In many ways, the math portion of the test is as much a test of reading as the verbal. Many of the math problems you will see start out as large blocks of text. When you see a large block of text, break it down into bite-sized pieces and solve the problem meticulously, one step at a time. Skipping or combining steps leads to trouble. Don't be afraid to read the problem out loud to yourself or to use your pencil to follow along with the text on the screen as you're reading. Reading too quickly leads to trouble, skipping words when you read (something all good readers do) leads to trouble, and careless errors will kill your score.

Ballparking

As a general rule, ballpark first and calculate second. Naturally you should end up ballparking more at the end of the section and calculating more at the beginning, but it's a good rule of thumb. Ballparking can take many forms. The first benefit to Ballparking is that you can't do it if you don't understand the question. The basic process of trying to come up with a ballpark range for an answer involves arriving at a conceptual understanding of what the question is asking. If you are at the tail end of a section, you might stop here and pick an answer. If you are in your first ten, you might use this as a way of figuring out how to go about determining the actual answer.

Always, Ballparking is a valuable way to check your work. GRE questions tend to make sense. The correct answer to a question asking for the number of students in a class will not contain a fraction (ETS won't generally chop a student in half). A question in which a person bicycles uphill one way and downhill on the way home, will not involve a distance greater than the distance a person could or would bike to work in a day. If you are asked for time, and you know that the round trip of 20 miles took two hours, then each leg would average 60 minutes. If you are looking for the downhill leg, any answer greater than 60 is wrong and any answer less than the amount of time an average person could reasonably bike ten miles is wrong. This is Ballparking. It won't necessarily eliminate four out of five wrong answers (although it could), but it will eliminate a few—and it will tell you the answer you generated actually makes sense.

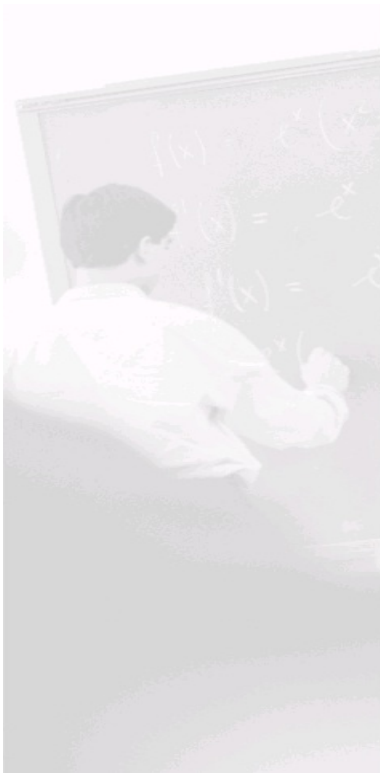

Diagnostic Test

Question 1

$$y \neq 0$$

Quantity A

$$5y^2$$

Quantity B

$$-\frac{y^2}{7}$$

- The quantity in Quantity A is greater.
- The quantity in Quantity B is greater.
- The two quantities are equal.
- The relationship cannot be determined from the information given.

Question 2

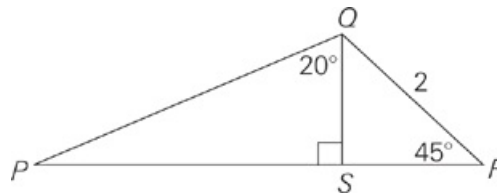

Quantity A

$$\sqrt{8}$$

Quantity B

The length of line segment PR

- The quantity in Quantity A is greater.
- The quantity in Quantity B is greater.
- The two quantities are equal.
- The relationship cannot be determined from the information given.

Question 3

Quantity A

$$35,043 \times 25,430$$

Quantity B

$$35,430 \times 25,043$$

- The quantity in Quantity A is greater.
- The quantity in Quantity B is greater.
- The two quantities are equal.
- The relationship cannot be determined from the information given.

Question 4

x and y are positive numbers.

Quantity A

$$\sqrt{x} - \sqrt{y}$$

Quantity B

$$\sqrt{x - 2\sqrt{xy} + y}$$

- The quantity in Quantity A is greater.
- The quantity in Quantity B is greater.
- The two quantities are equal.
- The relationship cannot be determined from the information given.

Question 5

Quantity A

The least prime factor of 7^2

Quantity B

The least prime factor of 2^7

- The quantity in Quantity A is greater.
- The quantity in Quantity B is greater.
- The two quantities are equal.
- The relationship cannot be determined from the information given.

Question 6

The average (arithmetic mean) of a , b , c , and d is 7.

Quantity A

15

Quantity B

The average (arithmetic mean) of $4a - 5c$, $b - 24$, $8c - a$, and $3d + 2b$

- The quantity in Quantity A is greater.
- The quantity in Quantity B is greater.
- The two quantities are equal.
- The relationship cannot be determined from the information given.

Question 7



In the figure above, the width of the larger square is equal to the diagonal (not shown) of the smaller square.

Quantity A

The area of the smaller square

Quantity B

The area of the shaded region

- The quantity in Quantity A is greater.
- The quantity in Quantity B is greater.
- The two quantities are equal.
- The relationship cannot be determined from the information given.

Quantity A

$$\frac{y+17}{y}$$

Quantity B

$$\frac{y+11}{11}$$

- The quantity in Quantity A is greater.
- The quantity in Quantity B is greater.
- The two quantities are equal.
- The relationship cannot be determined from the information given.

Question 9

The volume of a cube with edge of length 2 is how many times the volume of a cube with edge of length $\sqrt{2}$?

- $\sqrt{2}$
- 2
- $\sqrt{2}$
- 4
- 8

Question 10

BILLIE'S TIME SHEET FOR JULY 2

Time in:	8:57 in the morning
Time out:	5:16 in the afternoon
Time spent stacking shelves:	80% of total time spent at work

According to the time sheet above, Billie spent approximately how many hours stacking shelves on July 2?

- $5\frac{1}{3}$
- $6\frac{2}{3}$
- $7\frac{1}{3}$
- $8\frac{2}{3}$
- $9\frac{1}{3}$

Question 11

What is the probability that the sum of two different single-digit prime numbers will NOT be prime?

- 0
- $\frac{1}{2}$

- $\frac{2}{3}$
- $\frac{5}{6}$
- 1

Question 12

To fill a larger concert hall, a madrigal singing group consisting of sopranos, altos, and basses, in a 5:7:3 ratio, needs 40 singers. What is the least number of basses the group will need?

Question 13

If $mx + qy - nx - py = 0$, $p - q = 2$, and $\frac{y}{x} = -\frac{1}{3}$, then which of the following is true?

- $n - m = \frac{2}{3}$
- $n - m = -\frac{2}{3}$
- $m + n = \frac{2}{3}$
- $m + n = \frac{3}{2}$
- $m + n = -\frac{3}{2}$

Question 14

The “hash” of a three-digit integer with three distinct integers is defined as the result of interchanging its units and hundreds digits. The absolute value of the difference between a three-digit integer and its hash must be divisible by

- 9
- 7
- 5
- 4
- 2

SENIOR MANAGEMENT OF COMPANY Y
Average Salaries of Senior Managers at Company Y

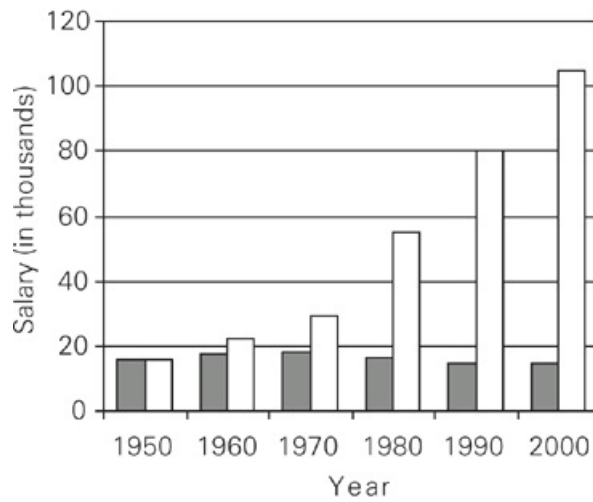

in 1950 dollars
 in actual-year dollars

Number of Senior Managers at Company Y

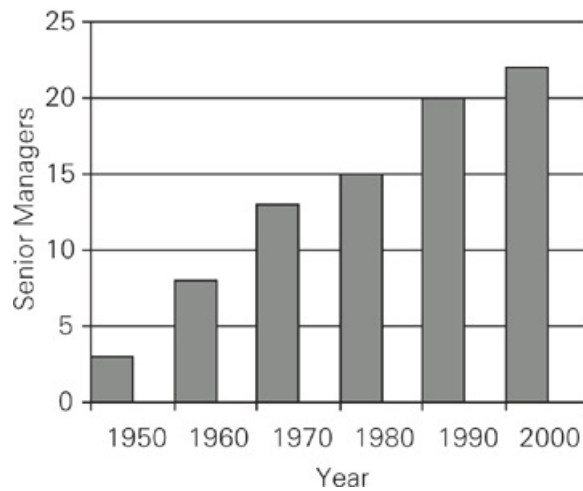

Question 15

If from 1980 to 2007, the number of senior managers increased by 60 percent, then what was the increase in the number of senior managers from 2000 through 2007, inclusive?

- 2
- 4
- 6
- 9
- 12

Question 16

Which of the following can be inferred from the data?

- From 1990 to 2000, the average salary, in 1950 dollars, increased by more than 10%.
- In 1960, there were fewer than 5 senior managers.

Choose all that apply.

Question 17

The positive sequence $S_1, S_2, S_3 \dots S_n \dots$ is defined by $S_n = S_{n-1} + 5$ for $n \geq 2$. If $S_1 = 7$ then the n th term in the sequence is

- $5n - 5$
- $5n - 2$
- $5n$
- $5n + 2$
- $5n + 7$

Question 18

Rachel and Rob live 190 miles apart. They both drive in a straight line toward each other to meet for tea. If Rachel drives at 50 mph and Rob drives at 70 mph, then how many miles apart will they be exactly 45 minutes before they meet?

- 50
- 60
- 70
- 90
- 100

Question 19

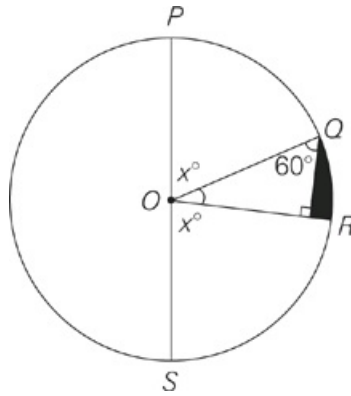

In the circle with center O above, $PS = 8$. If $x = 75$, then what is the perimeter of the shaded region?

- $6 - 2\sqrt{3}$
- $\frac{2\pi}{3}$
- $\frac{2\pi}{3} + 8$
- $\frac{2\pi}{3} - 2\sqrt{3} + 6$
- $\frac{2\pi}{3} + 2\sqrt{3} + 6$

If $x = 3^2$, then what is the value of x^x ?

- 3⁴
- 3⁸
- 3⁹
- 3¹²
- 3¹⁸

VERBAL

Question 1

British modernists used the literary tropes of fragmentation and failure to explore the impending ___(i)___ of British colonialism; illustrating the imminent ___(ii)___ of the empire through their literature.

Blank (i)	Blank (ii)
avarice	sunset
castigation	rise
dissolution	wealth

Question 2

Contemporary authors are much more at liberty to be candid than were authors of previous centuries, but modern writers nevertheless often find themselves ____ portions of their works.

- emancipating
- censoring
- refuting
- censuring
- ameliorating
- expurgating

Question 3

The development of hydrogen-powered cars will always be ___(i)___ by the physical fact that hydrogen, while containing more energy per gallon than does gasoline, is much less dense than gasoline; hydrogen thus carries less energy per pound, making it ___(ii)___ for any vehicle to carry enough hydrogen on board for long trips.

Blank (i)	Blank (ii)
enhanced	convenient
hindered	austere
parodied	ungainly

Question 4

One of the rarest of celestial events, the total solar eclipse only happens when the Moon, in its orbit around the Earth, fully ___(i)___ the view of the sun from a particular location on Earth. Because the Moon is relatively small, in celestial terms, and its umbra, the central part of the Moon's shadow caused by its blocking the sun, only traces a narrow path on the Earth, a total eclipse is such a ___(ii)___ occurrence that it typically draws hundreds of thousands of onlookers.

Blank (i)	Blank (ii)
secularizes	atypical
epitomizes	desultory
occludes	momentous

Question 5

To ___(i)___ people accurately, census workers must be ___(ii)___: because there are often residents of a household with the same name, or people whose names have unusual spellings, workers who are anything less than ___(iii)___ in following correct procedures and reviewing cases may result in the same resident getting counted multiple times, or even not at all.

Blank (i)	Blank (ii)	Blank (iii)
rectify	derivative	meticulous
tally	fastidious	perfunctory
impute	industrious	inexact

The journalist was ___(i)___ in his pursuit of the scandal he suspected: despite a lack of support from his editors, he was determined to investigate day and night, follow every lead, and write until dawn to get the story first and finally ___(ii)___ the big news agencies.

Blank (i)	Blank (ii)
decorous	scoop
digressive	forestall
indefatigable	deprecate

Over the last several decades, the demand for Country Y's automobiles increased in Country X but demand for Country X's automobiles in Country Y has remained stagnant. Initially, this disparity was plausibly due to Y's manufacturers having superior technology, which has yielded more fuel efficient cars with cheaper maintenance. However, now Country X's cars are comparable—if not slightly superior—in these respects. What Country X's manufacturers fail to acknowledge is that Country Y's drivers drive on the left side of the road. Clearly, to help lessen this trade imbalance, Country X manufacturers should produce more cars with right-side steering wheels.

Which of the following is an assumption made by the argument?

- Reversing the trade imbalance requires making right-side steering wheels.
- If Country X makes automobiles with right-side steering wheels, most consumers from Country Y will chose to purchase a car from Country X.
- If consumers from Country Y drive on the left side of the road, these consumers are less inclined to buy steering wheels found on the left-side of the car.
- Cars from Country X will continue to improve their fuel efficiency and reduce their maintenance costs.
- The government of Country Y requires all its citizens to purchase cars with right-side steering wheels.

Comparative historian Marc Ferro claims that the largest discrepancy in knowledge between what academic historians and what the average citizen knows about history is found in the United States. How has this situation come about? Certainly the problem does not lie with the secondary literature. Whereas in the past, American historians were handicapped by secondary literature that was clearly biased towards a European viewpoint, since the civil rights movement of the 1950s and 60s, the secondary literature in American history has become far more comprehensive. And it cannot be simply a matter of space constraints; the average high school history textbook is well over a thousand pages in length.

One theory holds that American history textbooks are simply the socializing instruments of a controlling elite. The stratification of American society is preserved, according to this theory, by the creation of what Marx termed "false consciousness." The theory holds that the way people think about their society and their history is crucial to maintaining the status quo. If the power elites come to believe that their success is the deserved product of their hard work and ingenuity, then there will be no desire to change the system. Similarly, if the lower classes are taught that their plight is solely due to their failings, they will be more likely to accept their fate and less likely to rise up in revolution. Griffin and Marciano contend that history textbooks promote nothing more than hegemony.

Many educational theorists share this viewpoint, which in their discipline is often known as critical theory. Proponents of this view, including Kozol, Freire, and Giroux, argue that the dominant classes would never create or foster an educational system that taught subordinate classes how to critically evaluate society and the injustices it contains. As long as schools serve to transmit culture, the power elite will never allow any real reform in the system.

It is all too easy to blame citizens' poor understanding of American history on some shadowy coterie of cultural aristocracy. But critical theory and other theories that lay the blame for American ignorance of history on the doorstep of the elites cannot explain their own success. Is it not a paradox that critical theory scholarship dominates its field? If the titans of society had as much power as the critical theorists contend, they would surely censor or marginalize the works of social scientists in this field. Furthermore, graduates of "elite" preparatory schools are exposed to alternative interpretations of history, subversive teachers, and unfiltered primary source materials more frequently than are students at public institutions. This would seem to indicate that the powerbrokers have little control over what happens at their very own schools, let alone far flung rural schools or schools deep in urban territory. The real culprit may be something not as insidious as a vast upper class conspiracy, but more along the lines of

pernicious forces working at a highly local level. Almost half of the states have textbook adoption boards consisting of members of the community. These boards review and recommend what (70) books are taught in neighborhood schools. And because textbook publishers are first and foremost seeking to maximize profit, it is these local boards that they must appease.

Question 8

Consider each of the following answer choices separately and select all that apply.

According to the passage, proponents of the critical theory believe which of the following?

- The creation of a false consciousness is a significant element in maintaining the stratification of American society.
- It is not in the interests of the powerful classes of society to engender critical reflection among the majority of citizens.
- Alternative interpretations of history may be taught to members of the upper classes, but not to members of the subordinate classes.

Question 9

It can be inferred from the passage that

- Marx was an early proponent of critical theory
- textbooks are not solely designed as teaching instruments
- the secondary literature on American history is no longer biased
- textbook publishers do not take the views of the power elite into account
- under the current system, real education reform is impossible

Question 10

Consider each of the following answer choices separately and select all that apply.

Which of the following statements about critical theory can be supported by the passage?

- It is simply another means by which the power elite preserves the stratification of American society.
- It does not contain any of the same biases which had appeared in the secondary literature prior to the civil rights movement.
- It is not unique in its attempts to attribute Americans' poor knowledge of history to the machinations of a particular class of individuals.

Question 11

Select the sentence in the first paragraph that explains why a problem is less severe for current American historians now than it was a century ago.

Question 12

Not only did the exhibit clearly show the health benefits of a vegetarian diet, it showed how those benefits often translate into a greater sense of _____.

- vitality
- mendacity
- remorse
- vigor

- contrition
- persecution

Question 13

While the author clearly identifies the importance of Victorian culture to twentieth-century technological advances, he _____ the importance of British Regency to the development of the social factors that influenced Victorian culture.

- intimates
- corroborates
- neglects
- placates
- trumpets
- omits

Question 14

The speaker, though well-read and articulate, had a tendency to be _____.

- eloquent
- elegant
- bombastic
- gregarious
- pompous
- affable

Question 15

Given that conditions were quite amenable to fruit trees during the growing season this year, the _____ of apples this fall is surprising.

- dearth
- countenance
- surfeit
- spate
- amalgamation
- paucity

Critics of Mark Twain's novel, *Huckleberry Finn*, view the protagonist's proclamation "All right, then, I'll go to hell" in chapter 31 as the story's climax. Twain's novel lent itself to such radical interpretations because it was the first major American work to depart from traditional European novelistic structures, thus providing critics with an unfamiliar framework. The remaining twelve chapters act as a counterpoint, commenting on, if not reversing, the first part in which a morality play receives greater confirmation. Huck's journey down the Mississippi represents a rite of passage, in which the character's personal notions of right and wrong come into constant conflict with his socially constructed conscience by the various people and situations the protagonist encounters.

The novel's cyclical structure encourages critics to see the novel's disparate parts as interlinked; the novel begins and ends with the boys playing games. Granted, this need not argue to an authorial awareness of novelistic construction; however, it does facilitate attempts to view the novel as a unified whole. Nevertheless, any interpretation that seeks to unite the last few chapters with the remaining book is bound to be tenuous. This is not because such an interpretation is unnecessarily rigid, but because *Huckleberry Finn* encompasses individual scenes of the protagonist's self-recognition that are difficult to accommodate in an all-encompassing interpretation. In this respect, the protagonist can best be likened to the Greek tragic figure, Oedipus.

Question 16

The author most probably mentions the "novel's cyclical structure" in order to

- demonstrate that Twain was keenly aware of novelistic construction
- show that the remaining twelve chapters have little connection to the rest of the novel
- support the critic's position that Twain was unaware of novelistic construction
- provide support for a particular critical interpretation of Twain's work
- argue that Twain's protagonist has much in common with Oedipus

Question 17

Which of the following best expresses the main idea of the passage?

- In order to understand Twain's novel, critics must compare its protagonist to Oedipus.
- Twain's novel contains some chapters that resist easy inclusion into a unified interpretation.
- The unconventional structure of *Huckleberry Finn* indicates a lack of authorial awareness.
- Twain's novel was the first major American novel to discard traditional European structures.
- The protagonist of *Huckleberry Finn* is considered a modern day Oedipus by critics.

One of the most noxious wind-borne allergens is ragweed (*Ambrosia*), as evidenced by an estimated 30 million sufferers in the U.S. alone and a societal cost of over \$3 billion. Each plant is able to produce more than a billion grains of pollen over the course of a season, and the plant is the prime cause of most cases of hay fever in North America. Although the plant produces more pollen in wet years, humidity rates above seventy percent tend to depress the spread of pollen by causing the grains to clump.

Ragweed spreads rapidly by colonizing recently disturbed soil, such as that engendered by roads, subdivisions, and cultivation and has adapted to a multitude of climatic conditions, including desert and high mountain areas. Complete elimination is virtually impossible. Physical removal is undone by even one seed or one bit of root left behind. Ragweed regenerates in about two weeks from only a half-inch of stem, usually with additional branching and flowering, so mowing can actually be counterproductive. Ragweed is susceptible to only the most aggressive herbicides, and because ragweed tends to cover large areas, control would mean widespread use of highly toxic chemicals. Control by natural predators? No known mammal browses on ragweed. Some species of *Lepidoptera* (butterflies, skippers, and moths) larvae feed on ragweed, but this arena of control is not well funded, and consequently not well-researched. Given the health issues and costs occasioned by ragweed, government funding for natural control research is warranted.

Question 18

Consider each of the following answer choices separately and select all that apply.

Which of the following can be inferred about the spread of ragweed pollen?

- Ragweed plants adapted to desert and mountain climates tend to spread fewer grains of pollen than do plants in other locations.
- Some attempts to control it may exacerbate the problem.
- The clumping of pollen grains caused by high humidity levels affects the ability of the wind to carry the grains.

Question 19

The author most probably mentions some species of *Lepidoptera* in order to

- detail a species that may be more effective at controlling ragweed than are the most aggressive herbicides
- suggest a potential research avenue to the problem of controlling ragweed that is at present poorly explored
- discuss a type of mammal that feeds on ragweed plants and may be successful at controlling the spread of ragweed
- plead with the government to spend more money and put more research efforts into finding a natural control for ragweed
- argue that complete elimination of the ragweed plant will only be possible if the government funds research into natural controls of ragweed

Friedrich Nietzsche's *Twilight of the Idols* expanded on the problem of the preponderance of reason in ancient Greek society, an issue he first broached in *The Birth of Tragedy*. The radical idea that Socrates was symptomatic of a decline Greek society based on the deification of rationality was almost unique among Enlightenment thinkers. Reaction to the idea in *The Birth of Tragedy*, in fact, was so negative among German academics that Nietzsche himself vacillated in his support, referring to the work as "impossible" and "embarrassing" in a preface to the second edition before returning to the notion in his later works. The antipathy of his peers is not surprising given that he took aim at such pillars of Western thinking as Plato, Socrates, even Christianity. Though originally widely refuted at the time of writing, themes related to the conflict between the rationality on one hand and the power of the senses on the other, were revisited time and time again by his successors.

Question 20

According to the author, proponents of Nietzsche's work would most likely agree that

- human reason is infallible whereas the senses decay along with the body and are therefore subservient to the mind
- there is a conflict between Socrates and traditional Christian thought
- Nietzsche had little influence on later thinkers
- privileging reason over the senses had a deleterious effect on Greek society at the time of Socrates
- Nietzsche found Plato to be embarrassing

ANSWERS

Math

1. A
2. B
3. A
4. C
5. A
6. C
7. C
8. D
9. C
10. B
11. C
12. 9
13. A
14. A
15. A
16. A
17. D
18. D
19. D
20. E

Verbal

1. dissolution, sunset
2. B, F
3. hindered, ungainly
4. occludes, atypical
5. tally, fastidious, meticulous
6. indefatigable, scoop
7. C
8. A, B
9. B
10. C
11. Whereas in the past, American historians...
12. A, D
13. C, F
14. C, E
15. A, F
16. D
17. B
18. B, C
19. B
20. D

Math

- A Since y^2 is always positive, Quantity A is positive and Quantity B is negative. The answer is choice (A). You can prove this by Plugging In several different values for y .
- B Straight angle PSR measures 180 degrees, so angle QSR must be 90 degrees, and angle SQR must be 45 degrees. So triangle QSR is a 45-45-90 triangle. Dividing QR by $\sqrt{2}$ gives you the lengths of QS and SR, that is, $\frac{2}{\sqrt{2}}$. Angle QPS measures 30° , so triangle PQS is a 30-60-90 triangle, and you can find PS by multiplying QS by $\sqrt{3}$ which gives you $\sqrt{6}$. Add the lengths of SR and PS to find the length of PR, which is $\sqrt{2} + \sqrt{6}$. But $\sqrt{2} + \sqrt{6} \neq \sqrt{8}$. Rather, simplify $\sqrt{8}$ to $2\sqrt{2} = \sqrt{2} + \sqrt{2}$. Compare this to Quantity B, and realize that you can ignore a $\sqrt{2}$ in each Quantity. $\sqrt{6}$ is greater than $\sqrt{2}$, so Quantity B is greater.
- A Before you start multiplying these huge numbers, realize that no GRE question requires a great deal of arithmetic. Notice that the three digits after the thousands place have merely been swapped to form Quantity B from Quantity A. So, represent Quantity A as $(35K + 43)(25K + 430)$ and Quantity B as $(35K + 430)(25K + 43)$ (note: K is short for 1,000). In FOILING these, you'll see that the result from multiplying the First expressions together is $(35K)(25K)$ in both quantities. Similarly, the result from multiplying the Last expressions is $(43)(430)$ in both quantities. So these expressions can be ignored in comparing the two quantities. All that remains is the Outer terms added to the Inner terms. In Quantity A, this is $(35K)(430) + (43)(25K)$, and in Quantity B, this is $(35K)(43) + (25K)(430)$. If you factor out 43 from each Quantity, you obtain $43(350K + 25K)$ and $43(35K + 250K)$, or $43(375K)$ and $43(285K)$ for Quantities A and B, respectively. Quantity A is larger. If you were pressed for time, you might also note that the bigger number (35,000) is multiplied by 430 in Quantity A but only by 43 in Quantity B.
- C Quantity B contains a common quadratic pattern. Factor the right-hand side $\sqrt{x - 2\sqrt{xy} + y} = \sqrt{(\sqrt{x} - \sqrt{y})^2} = \sqrt{x} - \sqrt{y}$. Both quantities are equal, so the answer is choice (C).
- A The quantities are already represented as the product of prime factors: $7^2 = (7)(7)$, so the least prime factor of Quantity A is its only prime factor, 7. Similarly, $2^7 = (2)(2)(2)(2)(2)(2)(2)$, so Quantity B is 2. Be careful! Remember that you are being asked to determine the greater of these two quantities. The answer is choice (A).
- C To find the average of a list of numbers, add them up and divide by the number of elements in the list. You are told that $\frac{a+b+c+d}{4} = 7$ so $a + b + c + d = 28$. You can substitute this into the simplified form of Quantity B as follows:

$$\frac{(4a - 5c) + (b - 24) + (8c - a) + (3d + 2b)}{4} = \frac{3a + 3b + 3c + 3d - 24}{4} = \frac{3(a + b + c + d) - 24}{4} = \frac{3(28) - 24}{4} = \frac{60}{4} = 15$$
Both quantities are equal, so the answer is choice (C). Alternatively, you can plug in values for a , b , c , and d . The easiest way to make their average equal 7 is to plug in 7 for all four values.
- C Plug in an easy number for the width of the smaller square, such as 3. So the area of the smaller square is $s^2 = 3^2 = 9$. Drawing in the diagonal of a square forms two 45-45-90 triangles, so the diagonal (the hypotenuse of either triangle) has length $3\sqrt{2}$. You are told that this is the width of the larger square, so the area of the larger square is $s^2 = (3\sqrt{2})^2 = 18$. The area of the shaded region is the result when the area of the smaller square is subtracted from that of the larger: $18 - 9 = 9$. Thus, both quantities are equal, and the answer is choice (C).
- D First, simplify the expression in each quantity by splitting up the fraction. Thus, Quantity A becomes $1 + \frac{17}{y}$ and Quantity B becomes $\frac{y}{11} + 1$. Both quantities contain 1, so it can be eliminated from the comparison. Now plug in 12 for y : Quantity A becomes $\frac{17}{12} = 1\frac{5}{12}$ and Quantity B becomes $\frac{12}{11} = 1\frac{1}{11}$. Quantity A is larger, so eliminate choices (B) and (C). Now plug in 16 for y : Quantity A becomes $\frac{17}{16} = 1\frac{1}{16}$, and Quantity B becomes $\frac{16}{11} = 1\frac{5}{11}$. Quantity B is larger, so eliminate choice (A); the answer is choice (D).
- C The volume of the larger cube is $s^3 = 2^3 = 8$ and the volume of the smaller cube is $s^3 = (\sqrt{2})^3 = 2\sqrt{2}$. Dividing the larger by the

smaller yields $\frac{8}{2\sqrt{2}} = \frac{4}{\sqrt{2}} = \frac{4\sqrt{2}}{2} = 2\sqrt{2}$ and the answer is choice (C).

10. B First, figure out how many hours Billie worked. From 9 a.m. to 5 p.m. is 8 hours. She started work 3 minutes before 9 a.m. and finished at 16 minutes after 5 p.m., for a total of 19 more minutes, which is close to 20 minutes, or $\frac{1}{3}$ of an hour. So Billie worked approximately $8\frac{1}{3}$ hours. To take 80 percent of this, multiply by $\frac{80}{100} = \frac{4}{5}$. So she spent $\left(\frac{4}{5}\right)\left(8\frac{1}{3}\right) = \left(\frac{4}{5}\right)\left(\frac{25}{3}\right) = \frac{100}{15} = 6\frac{2}{3}$ hours; the answer is choice (B).
11. C The single-digit primes are 2, 3, 5, and 7. Be systematic in listing the results. Start with 2, adding it to the other numbers, then move to 3, and so forth: $2 + 3 = 5$; $2 + 5 = 7$; $2 + 7 = 9$; $3 + 5 = 8$; $3 + 7 = 10$; $5 + 7 = 12$. Out of these six results, 5 and 7 are prime, but the other four results are not, so the probability you seek is $\frac{4}{6} = \frac{2}{3}$ and the answer is choice (C).
12. 9 With a ratio of 5:7:3, the total number of singers must be at least 15. If you double the number, and keep the ratio, there would be 30 singers. To have at least 40 singers with the same ratio, the actual total would be 45, or 3 times 15, which means there are three times the number of basses (3) in the ratio, or 9.
13. A Notice that the question gives you information about p and q, and the answer choices refer to m and n. Therefore, you need to isolate those from the variables x and y by factoring. Regrouping the first given equation gives you $(m - n)x + (q - p)y = 0$. Because $p - q = -(q - p)$, the second given equation tells you that $q - p = -2$. Cross-multiplying the third given equation yields $x = -3y$. Substituting the last two results into the regrouped first equation yields $(m - n)(-3y) + (-2)y = 0$. Moving the second expression to the other side of the equation yields $(m - n)(-3y) = 2y$. Inspecting this equation tells you that $(m - n)(-3) = 2$, so $m - n = -\frac{2}{3}$. Because $m - n = -(n - m)$, you know that $n - m = \frac{2}{3}$ and the answer is choice (A).
14. A Plug in a three-digit integer, such as 341. Swapping the 1 and the 3 gives you 143. Subtracting 143 from 341 gives you 198 (which is already positive, so its absolute value is also 198). 198 is not divisible by 7, 5, or 4, so eliminate choices (B), (C), and (D). Plug in another number, such as 546. Its hash is 645. Subtracting 546 from 645 gives you 99, which is not divisible by 2, so eliminate choice (E). Even if the hundreds digit or the units digit are zero, the difference between a three-digit integer and its hash is still divisible by 9. The answer is choice (A).
15. A The number of senior managers in 1980 was 15. To find 60 percent of this, multiply $\frac{60}{100}(15) = \frac{3}{5}(15) = 9$. So in 2007, there were $15 + 9 = 24$ senior managers. In 2000, there were 22, so the increase from 2000 to 2007 was 2; the answer is choice (A).
16. A In the first bar graph, the average salary, in 1950 dollars, actually appears to have slightly decreased from 1990 to 2000, so statement I is false. Eliminate choices (B) and (E). In the second bar graph, there were 8 senior managers in 1960, so statement II is also false. Eliminate choices (C) and (D); the answer is choice (A).
17. D Plug in 2 for n to find the second term in the sequence: $s_n = s_{n-1} + 5$ so $s_2 = s_{2-1} + 5 = s_1 + 5 = 12$, your target number. Now plug in 2 into the answer choices for n to see which equals 12. Only choice (D) works.
18. D Together, Rachel and Rob cover 120 of the 190 miles in one hour. This means that they cover $\frac{3}{4}$ that distance in $\frac{3}{4}$ that time, that is, 90 miles in any 45-minute period. So, 45 minutes before they meet, they are 90 miles apart, and the answer is choice (D). If you picked choice (E), you found how far they had traveled 45 minutes before they met, rather than how far they had left to travel.
19. D If $x = 75$, both angles marked x add up to 150 degrees, so the remaining angle in the semicircle (angle QOR) must measure 30 degrees. PS is a diameter, so the circumference of the circle must be $\pi d = 8\pi$. The length of arc QR must represent the same fraction

of the circumference as central angle QOR does of 360 degrees: $\frac{30^\circ}{360^\circ} = \frac{\text{length of } \widehat{QR}}{8\pi}$ so the length of arc QR is $\frac{2\pi}{3}$. The diameter of the circle is 8, so radii OQ and OR have length 4. The triangle inside sector QOR is a 30-60-90 triangle because angle QOR measures 30 degrees and you are shown a right angle. The remaining angle must be 60 degrees to add up to 180. So, the leg of the triangle across from the 30 degree angle will be half of OQ, which is 2, and the other leg that forms part of radius OR will have length $2\sqrt{3}$. So, the remainder of radius OR must have length $\sqrt{3}$. Adding the three edge lengths of the shaded region gives you $\frac{2\pi}{3} + 2 + (4 - 2\sqrt{3}) = \frac{2\pi}{3} - 2\sqrt{3} + 6$ the answer is choice (D).

20. E First, evaluate x: $x = 3^2 = 9$. Notice that the answers are presented as powers of 3, not a list of actual numbers. So $x^x = (3^2)^9 = 3^{18}$, and the answer is choice (E).

1. dissolution and sunset

This sentence employs parallel structure, and the semicolon trigger tells you that both blanks will go in the same direction; either of your two clues, fragmentation or failure, can be recycled into both blanks. Of the choices for the first blank, only dissolution makes sense; of the choices for the second blank, only sunset is sufficiently negative.

2. B and F

The clue in the sentence is much more at liberty to be candid. The triggers are but and nevertheless. Both triggers are opposite-direction triggers, so the correct answer must mean something that relates to the opposite of to be candid. A good word for the blank therefore might be deleting. Emancipating means setting free, which is not quite the same as deleting, so you can eliminate choice (A). Censoring means deleting, so choice (B) is a correct answer. Refuting means proving false, so choice (C) is incorrect. Censuring means expressing strong disapproval, so choice (D) is not a credited answer. Ameliorating means easing or lessening, and does not mean deleting, so you can eliminate choice (E). Expurgating means changing by removing words, so choice (F) is a correct answer.

3. hindered and ungainly

The trigger while introduces two conflicting aspects of hydrogen-powered cars. The first clue states that hydrogen contains more energy per gallon than does gasoline, which would seemingly aid the development of hydrogen-powered cars; since the trigger changes the direction of the sentence, though, a word that means made more difficult would make sense in the first blank. Of the choices, only hindered fits. Both the semicolon and the thus tell you that the second blank agrees with the first, so you need a word that means something like difficult or awkward. Of the choices, only ungainly makes sense.

4. occludes and atypical

The first blank describes what the Moon does to the Sun; the second sentence tells you that the Moon's shadow is caused by blocking the sun, so you are looking for a word that means blocks. Of the choices, only occludes means blocks; secularizes means separates from religious connection and epitomizes means typifies. The second blank describes the occurrence, and the clue is in the first line of the passage: one of the rarest of celestial events. Therefore, you need a word that means rare. Of the choices, only atypical means rare; desultory means random, but not necessarily rare, and momentous means of far-reaching importance—which may also describe the event, but isn't supported in the passage.

5. tally, fastidious, and meticulous

The first blank describes what census workers do to people, so you need a word for the blank that means count. Of the choices, only tally means count. The second blank describes accurate census workers; the part after the colon outlines some of the problems associated with not paying attention to details, so a word that means something like attentive to details would make sense. Of the choices, fastidious is the best fit. The third blank, like the second, describes the ideal census worker, so once again you need something that means attentive to details. Of the choices, only meticulous means attentive to detail; both perfunctory and inexact are nearly the opposite of what you need.

6. indefatigable and scoop

The first blank describes the journalist's pursuit of the story; since he's investigating day and night and writing until dawn, a word like tirelessly would make sense in the blank. Of the choices, indefatigable—literally, not able to be fatigued—is the best fit. The clue for the second blank is get the story first; scoop has a secondary meaning of beating other news sources to a story, so that's your best choice.

7. C Choice (A) is not necessary—it strengthens the argument. In fact, it guarantees that the conclusion is true, but it's not the assumption. I don't need reversing the trade imbalance to require the plan advocated in the passage. I only need the plan to help lessen the imbalance. The same problem exists in choice (B): I don't need most consumers from Y to purchase cars from X in order to help lessen the trade imbalance. Choice (C) says that if they are not inclined to buy them, then the plan is no good. Thus, this is essential to the plan working. Choice D is not necessary: I don't need Country X's cars to continue to improve. I only need them to continue to be comparable to Country Y's cars. Choice (E) makes me like the plan but it is not essential. I don't need the preference for right side steering wheels to be government-mandated.

8. A and B

Be sure to use both the second and third paragraphs to answer this question: Although the term critical theory doesn't appear until the latter, it's used to describe the viewpoint discussed in the previous paragraph. Choice (A) is supported by the sentence in the second paragraph that states that American society is preserved ... by the creation of what Marx called "false consciousness." Choice (B) is also supported by the sentence in the third paragraph that states that dominant classes ... and the injustices it contains. Choice (C), however, is contradicted by information in the final paragraph and is stated in extreme language that is rarely correct on the GRE.

9. B Choice (B) is supported by the final lines of the passage, which indicate that textbook publishers are first and foremost seeking to maximize profit. Thus, textbooks are not just teaching instruments, but money makers. Choice (A) is not supported by the passage. The theorists use Marx's term, but that doesn't mean he was a member of the school. Choice (C) is wrong; the passage simply says the literature is more comprehensive. That's not the same as saying it is no longer biased. Choice (D) is not supported by the passage. Although the author rejects the idea that the power elites are in control of textbooks, it may still be true that publishers take their views into account. Choice (E) is put forth by the critical theorists, but it is not necessarily true.

10. C Choice (C) is supported by the reference in the third paragraph to critical theory to critical theory ... on the doorstep of the elites; if there are other theories that similarly lay blame, then critical theory is not unique. Choice (A) is not supported: Critical theory is used by educational theorists, not the power elite. Choice (B) is also not supported: Critical theory is discussed as an attempt to explain Americans' alleged ignorance of history, which can no longer be attributed to the less comprehensive secondary sources that were common before the civil rights movement.
11. Whereas in the past, American historians...
After introducing the main idea, most of the first paragraph is spent dismissing possible causes for the discrepancy that Ferro claims. The third sentence absolves the secondary literature as a suspect; if you selected this sentence, you may have failed to clarify that the problem asked for the sentence that explains why. The fourth sentence gives the desired reason: The secondary literature became more comprehensive after the civil rights movement of the 1950s and 60s. If you chose the fifth sentence, note that the passage doesn't state whether space constraints were ever a problem.
12. A and D
Not only tells you that the second part of the sentence will continue in the same direction as, and expand upon, the first part of the sentence. The first part says an exhibit showed a vegetarian diet is healthy, so the second part will also say the exhibit showed something positive about a vegetarian diet, and it will likely be relevant to health. Remorse and contrition are synonymous but are too negative for what you're looking for. Mendacity, which means deception, and persecution, which means an attack on an ethnic group, are also too negative to be extensions of health benefits. On the other hand, vitality and vigor both mean having lots of energy, which is a congruous and logical extension of the health benefits of a diet.
13. C and F
While is a trigger word, so you know that the second clause will contrast with the first. The first clause states that the author does identify Victorian culture, so the second clause will be about a failure to identify something. Thus, choices (A) and (E) can be eliminated, since they suggest successfully communicating something. To corroborate, choice (B), means to validate a story. To placate means to appease, so choice (D) doesn't make sense here. To neglect and to omit both suggest a failure; choices (C) and (F) are correct.
14. C and E
The trigger though tells you that the latter part of the sentence will contrast with well-read and articulate, so you're looking for words that indicate negative attributes of a speaker. Eloquent and elegant both have positive meanings, so eliminate choices (A) and (B). Gregarious and affable both mean highly social, and so are too positive as well as irrelevant to the sentence; eliminate choices (D) and (F). Bombastic and pompous both mean prone to ostentatious speech, so answer choices (C) and (E) give you appropriate, equivalent sentences.
15. A and F
The trigger word comes at the very end of this sentence: Since the speaker indicates surprise, the second half of the sentence will contrast with the first, which says that conditions for apples were good. So you're looking for words that indicate the apples are poor in some way, and both dearth and paucity indicate a lack or shortage. Surfeit and spate are also synonyms, but they have the opposite meaning: an abundance or excess. Neither countenance, which means the look on one's face, nor amalgamation, which means combination, fit here. Choices (A) and (F) are the best answers.
16. D According to the author, The novel's cyclical structure encourages critics to see the novel's disparate parts as interlinked ... however, it does facilitate attempts to view the novel as a unified whole. Thus, the cyclical structure supports a critical interpretation of the novel. Choice (D) best summarizes this idea.
17. B In the first paragraph, the author states, The remaining twelve chapters act as a counterpoint, commenting on—if not reversing,—the first part where a morality play receives greater confirmation. According to the second paragraph of the passage, Huckleberry Finn encompasses individual scenes of the protagonist's self-recognition, that resist inclusion into an all-encompassing interpretation. Throughout the passage, the author shows that the novel has certain elements that do not fit nicely into a unified vision of the book. Choice (B) is the best restatement of the information given in the passage.
18. B and C
Choice (A) is not supported, because the passage never compares the rates of pollen production in plants at different climates. Choice (B) is supported by the phrase mowing can actually be counterproductive. Choice (C) is supported by statement that high humidity rates reduce the spread of ragweed, a wind-borne allergen, by causing the grains to clump. The clumping must have some negative effect on the wind's ability to carry the pollen, making choice (C) true.
19. B The answer to this question lies in the line, Some species of Lepidoptera (butterflies, skippers, and moths) larvae feed on ragweed, but this arena of control is not well funded, and consequently not well-researched. The author mentions the species to indicate that there may be a potential answer to the problem of controlling ragweed, but this answer has not been fully explored. This most closely matches choice (B). Choice (A) is wrong because the author doesn't make a comparison between the methods of control. Choice (C) is wrong because the species discussed are not mammals. The author does suggest the government explore natural remedies, but choice (D) doesn't properly answer the question. The mention of some species of Lepidoptera is not used to plead with the government. Choice (E) is incorrect because earlier in the passage the author indicates that complete elimination of the ragweed is unlikely.

20. D The passage tells us that Socrates was an example of the type of thinking that led to a decline in Greek society. His thinking deified rationality, or put it on top. Later on in the passage we are told that there is a conflict between rationality and the senses. Thus, the author implies that Nietzsche felt that Socrates' excessive rationality was a problem. The answer is choice (D).



The Verbal Section

The Verbal section of the GRE is designed to test your verbal reasoning abilities. This chapter will explain what types of questions ETS uses to accomplish that. You'll also see how the concepts of Personal Order of Difficulty and Process of Elimination apply to the Verbal section. Finally, you'll learn what role vocabulary plays in achieving a good score on the Verbal section.

What's On It?

Now that ETS has redesigned the GRE, the company claims that the new Verbal section will accomplish the following:

- Place a greater emphasis on analytical skills and on understanding vocabulary in context rather than in isolation
- Use more text-based materials
- Contain a broader range of reading selections
- Test skills that are more closely aligned with those used in graduate school
- Expand the range of computer-enabled tasks

While those sound like lofty and admirable goals, what they really translate into are the following changes:

- There won't be questions that involve analogies or antonyms on this test, as there have been on past tests (and good riddance!).
- You'll see new question types that weren't on the old version of the test: Critical Reasoning questions and Sentence Equivalence (in which you search for synonyms—somewhat easier and more reasonable than the antonyms questions, but not by much).
- The test writers made minor tweaks to the Text Completion and Reading Comprehension questions (we'll get into how these are constructed later in this section).
- You'll see some wacky-looking question formats that you've probably never seen before.
- Though they say the new version of the test de-emphasizes vocabulary, there's no getting around the fact that the more vocabulary you know when you sit down to take the test, the better off you'll be.

Of course, ETS claims that the new GRE is a better and more valid test than the previous incarnation, but we have our doubts. For one, there hasn't been much testing done on the new question types. In other words, ETS hasn't tried these questions out on test takers to see how well they evaluated knowledge or ability. Second, the new test is longer and less convenient for students—but more on that later. Suffice it to say that we're not totally convinced that this test represents an improvement over those of the past.

There are three types of questions on the Verbal section of the test. They are:

- Text Completions
- Sentence Equivalence
- Reading Comprehension



Text Completions

TEXT COMPLETIONS

Text Completions occupy a middle ground between Sentence Equivalence and Reading Comprehension. You will be given a small passage—one to five sentences—with one, two, or three blanks. If the passage has one blank, you will have five answer choices. If it has two or three blanks, you will be given three answer choices per blank. You have to independently fill in each blank to get credit for the question.

The overall approach is the same. Ignore the answer choices. Find the story being told (there will always be a story), and come up with your own words for the blank. Here's what a three-blank Text Completion will look like:

Question 5

Proponents of the International Style in architecture called for reducing buildings to purely functional form and found beauty in highlighting __ (i) __ features. They rejected references to __ (ii) __ and historical styles and offered designs indifferent to location, a quality subsequently __ (iii) __ by those who viewed the style as bland or unappealing.

Blank (i)	Blank (ii)	Blank (iii)
structural	oracular	disparaged
aesthetic	vernacular	embraced
hackneyed	secular	reclaimed

Step 1—Find the Story

There will always be a story. There must be a complete enough story that you can identify what's missing. The answer choices are there to mislead you, so don't look at them. Stay with the passage until the story comes into focus. Pay particular attention to trigger words (see Sentence Equivalence). They will indicate the direction of the sentence and will help to fill in blanks. If the sentence does not come into focus, skip it and come back after doing a few other questions.

Step 2—Prep Your Scratch Paper

As opposed to columns of A's, B's, C's, D's, E's, and F's, Text Completion scratch paper will look like this:

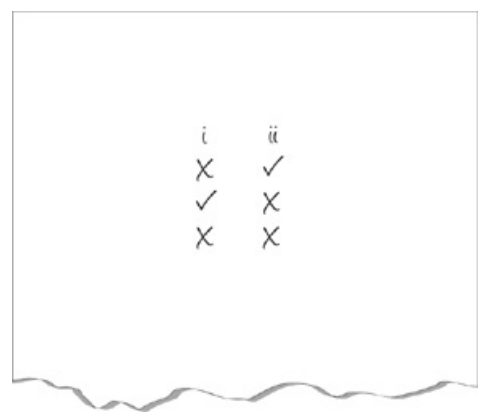

Step 3—Pick a Blank

Some blanks will be easier to fill in than others. In general, blanks have two roles. They either test vocabulary, or comprehension. A blank testing vocabulary may be easy to fill in with your own words, but then the answer choices may consist of difficult vocabulary words. A blank testing comprehension may depend upon what you put in another blank, or may contain multiple words, including a few trigger words and prepositions. Start with whichever blank seems the easiest.

Step 4—Speak for Yourself

The answer choices will all fit grammatically into the sentence and quite a few of them will make some sense. Plugging them in to see which one "sounds" right, is just what ETS wants you to do. Sooner or later, with this approach, they will tempt you into a wrong answer. Instead, stay with the sentence until the story becomes clear and then come up with your own word for the blank. If you don't know exactly what word will fit, at least figure out whether the word in the blank will change the direction of the sentence or keep it the same.

Step 5—POE

Keep your hand moving. Do not do this process in your head. That leads to mental stress and unnecessary mistakes. Park your thinking on your scratch paper.

Step 6—Rinse and Repeat

Repeat this process for each blank. Remember that some blanks will test vocabulary, but others will test comprehension. Often the information you need for one blank may happen to be another blank. For this you will need to identify the relationship between the blanks.
www.ZTCprep.com

That may seem like a long process, but it's really just a way of thinking. Find the story. Play close attention to trigger words. Come up with words for the blank or establish direction. Keep the hand moving and eliminate.



Text Completion Drills

DRILL 1

Directions: For each blank select one entry from the corresponding column of choices. Fill all blanks in the way that best completes the text.

Question 1

Just as different people can have very different personalities, so too can pets—even those of the same species and breed possess varied ____.

initiations
implementations
aptitudes
rationalizations
temperaments

Question 2

Frustrated by her husband’s lack of ___(i)___, Lisa tried to motivate him to ___(ii)___ for greater things.

Blank (i)	Blank (ii)
initiative	mitigate
lassitude	invigorate
eloquence	strive

Question 3

At the edges of the universe astronomers have discovered ___(i)___ objects called quasars, which have given scientists the first direct ___(ii)___ of the existence of stars in distant galaxies.

Blank (i)	Blank (ii)
remote	corroboration
paranormal	distortion
viscous	intuition

Question 4

If one were asked who transmitted the first radio broadcast of the human voice, one might guess the ____ inventor Guglielmo Marconi, but in fact the feat was accomplished by the much less well-known Reginald Fessenden.

infamous
renowned
contingent
cogent
insistent

Question 5

The difference in economic terms between a bond and a note is still observed by the United States Treasury, but in other markets the ___(i)___ the two terms has become unimportant and the two words are used ___(ii)___.

Blank (i)	Blank (ii)
distinction between	statistically
similarity of	interchangeably
usefulness of	differentially

Question 6

Now known as Administrative Professionals’ Day, Secretaries’ Day was created in 1952 by Harry F. Klemfuss, a public relations professional who ____ the value and significance of administrative assistants in order to attract more women to the profession.

proscribed
touted
refuted
undermined
admonished

Question 7

When editing manuscripts, literary scholars must remain acutely aware of textual ___(i)___; the differences among extant versions of the same work—resulting from printing errors, editing demands, or constant revisions—often make it ___(ii)___ for scholars to publish truly ___(iii)___ texts.

Blank (i)	Blank (ii)	Blank (iii)
conformities	pejorative	cosmetic
anomalies	daunting	innovative
congruities	banal	authoritative

Question 8

With a similar contrast between a partly cloudy sky and a dark street, the cover of the recent rock CD ____ a famous surrealist painting from the early 1900s.

admires
obfuscates
evokes
disenchants
sanctions

Question 9

Although John F. Kennedy was known for his carefree flag football games, Gerald Ford should be ____ as our football president: He turned down offers to play for two National Football League teams in order to pursue a career in public service.

relegated
abrogated
annulled
criticized
apotheosized

Question 10

Though many ____ endlessly praised his work, Dan often wished for some honest criticism.

sycophants
pedants
benefactors
adversaries
mavericks

Question 11

The losing game show contestant experienced a strange mix of ___(i)___ and ___(ii)___; although she was disappointed that she didn't win the million dollar prize, she was still ___(iii)___ about returning to her normal life.

Blank (i)	Blank (ii)	Blank (iii)
despondency	ambivalence	confounded
fruition	elation	euphoric
decisiveness	equivocation	overwrought

The magazine article from 1956 decrying the ___(i)___ of sequels and remakes flooding the nation's movie theaters that summer ___(ii)___ the claim that such derivative films are a uniquely 21st-century phenomenon.

Blank (i)	Blank (ii)
dearth	underscored
quality	belied
glut	predicted

Question 13

Although considerable ___(i)___ resources had already been expended on the new drug, development had to be halted due to adverse effects during human testing; once hailed as a kind of ___(ii)___ that could be used to treat numerous physical and mental ailments, the drug will likely be remembered only as a financial albatross that bankrupted its developers.

Blank (i)	Blank (ii)
assiduous	sinecure
pecuniary	mendicant
wholesome	panacea

Question 14

Sheila would often ___ about her boyfriend's habits, but everyone could tell that her seemingly bitter complaints were mostly facetious.

waffle
rail
dissemble
grieve
mince

Question 15

Although the stress tests given to European banks are supposed to reassure ___(i)___ investors by distinguishing the reliable financial institutions from the more ___(ii)___ ones, the lack of candor from those reporting has made the test results ___(iii)___.

Blank (i)	Blank (ii)	Blank (iii)
prolix	precarious	monetary
cantankerous	staunch	suspect
timorous	venerated	sound

DRILL 2

Directions: For each blank select one entry from the corresponding column of choices. Fill all blanks in the way that best completes the text.

Question 1

Carey and Skylar's constant bickering dismayed their mother, who had grown weary of their ____.

squabbles
laudations
affectations
procrastinations
humor

Question 2

The Mayor was so ____ by the long trial that, despite his eventual acquittal, he admitted his failing health and declined to run for re-election.

distraught
exonerated
inspired
debilitated
vindicated

Question 3

Despite her hearing loss and ____(i)___ painful arthritis, Maj was a pleasant and surprisingly ____(ii)___ dog.

Blank (i)	Blank (ii)
mildly	enervated
chronically	agile
sympathetically	acute

Question 4

While any bird egg will suffice for the tradition of egg decorating, those with ____ shells are preferred, so as to prevent breaking when their contents are hollowed.

tenuous
pristine
permeable
resilient
obtuse

Question 5

Hand-cuffing the two ____(i)___ men stopped the ____(ii)___ violence, but did nothing to cease the volley of ____(iii)___ they continued to yell at each other.

Blank (i)	Blank (ii)	Blank (iii)
prevaricating	corporeal	epithets
moiling	rhetorical	blows
belligerent	histrionic	projectiles

Question 6

Though she willingly admitted that the ____(i)___ town was scenically beautiful, Christine could not help but feel it was ____(ii)___ backwater compared to her previous home in the city.

Blank (i)	Blank (ii)
sprawling	a cultural
desolate	an attractive
bucolic	a picaresque

Question 7

The Roman Empire's military and political ____ was often challenged by the smaller but ambitious Persians, who for centuries fought wars intended to usurp Rome's dominion.

heterodoxy
methodology
hegemony
impotence
timorousness

Question 8

The chairman's __(i)__ comments about the environmental disaster caused people to grow even angrier at the company, __(ii)__ a situation that was already __(iii)__.

Blank (i)	Blank (ii)	Blank (iii)
compassionate	edifying	parlous
glib	exacerbating	inured
solicitous	mollifying	compliant

Question 9

Allowing distinguished figures to __(i)__ on their experiences, lives and wisdom learned, the memoir genre has given us such significant works as Ulysses S. Grant's Personal Memoirs, an interesting, well-written account of his days as a general and a president. At the opposite end of the spectrum, the genre also provides an outlet for anyone who wants to share any __(ii)__ experience, as evidenced by the __(iii)__ release of a fly-by-night internet celebrity's memoir next month.

Blank (i)	Blank (ii)	Blank (iii)
extemporize	apocryphal	laudable
expatiate	petty	laughable
exagitate	eccentric	impending

Question 10

Although Father's Day, first celebrated in 1908, is now an honored tradition in the United States, it did not always enjoy such __(i)__; rather, unofficial __(ii)__ from prominent figures such as Woodrow Wilson and William Jennings Bryan were required before Americans embraced the holiday.

Blank (i)	Blank (ii)
decorum	opprobrium
ennui	accolades
esteem	hyperbole

Question 11

Some conservative theologians subscribe to the belief of Biblical __(i)__ as far as the Scripture never being wrong when it comes to revealing God, his vision, and his news to humanity. However, other literalist Christians believe the __(ii)__ refers to the Bible being without error in every way, including matters of chronology, history, biology, sociology, politics, et cetera.

Blank (i)	Blank (ii)
inerrancy	centurion
fallacy	erudition
interpretation	doctrine

When he was alive, the magnate was described as arrogant, bitterly critical, and ___(i)__. Nevertheless, the speaker, who was often the victim of his legendary ___(ii)__, was able to find ___(iii)__ things to say about him.

Blank (i)	Blank (ii)	Blank (iii)
efficacious	diatribes	magnanimous
bellicose	encomiums	imperious
chastened	eulogies	vindictive

Question 13

When the mother ___(i)__ the disruptive child, she did not expect his siblings to encourage malevolent behavior; rather, she anticipated that the children would mock and ___(ii)__ their troublesome brother and through this punishment, he would refrain from harassing others.

Blank (i)	Blank (ii)
touted	deride
calumniated	laud
pilloried	renege

Question 14

Many city-dwellers have a ____ of knowledge about their food sources: indeed, a number of people have never even seen a live chicken or cow.

pith
dross
surfeit
dirge
dearth

Question 15

Most fans dismissed the press release detailing the comedian's ill health as a hoax, as she had frequently ____ her audience by feigning a physical ailment as part of her stage routine.

reconnoitered
hoodwinked
lambasted
vitiated
derided

DRILL 3

Directions: For each blank select one entry from the corresponding column of choices. Fill all blanks in the way that best completes the text.

Question 1

An aloe plant may be an excellent choice for those who are interested in gardening but keep busy schedules; aloes easily ____ without frequent watering or careful maintenance.

facilitate
ingest
consume
flourish
advance

Question 2

Howard's friends recognize that his nervous ____(i)__ on meeting strangers belies an underlying gregariousness, while new acquaintances often ____(ii)__ perceive him as churlish.

Blank (i)	Blank (ii)
chatter	falsely
silences	accurately
banter	quickly

Question 3

The artist, who specialized in ____ scenes, eagerly sat down to paint his favorite landscape—a peaceful pasture filled with hills and valleys.

halcyon
perennial
bucolic
eclectic
quiescent

Question 4

Her performance review noted that Jill suffers from a lack of ____(i)__, and often makes insulting remarks despite her best efforts to be polite; worse, the review went on to point out that it happens regularly, even though she has no intention of ____(ii)__ anyone.

Blank (i)	Blank (ii)
candor	exacerbating
tact	lauding
deference	denigrating

Question 5

The administration had nothing but contempt for the ultimate Frisbee team and frequently spoke ____ of it.

didactically
affably
jocularly
morosely
disdainfully

Question 6

By disclosing and explaining the details of her personal finances before they could be used against her, the council member ____(i)____ her opponent's attacks during the campaign. Rather than waiting to react to the inevitable criticism should her opponent find

something questionable, her campaign manager thought this strategy would be more ___(ii)___.

Blank (i)	Blank (ii)
prefigured	enigmatic
decried	pragmatic
precluded	dogmatic

Question 7

Lindsay, cognizant of the effects of second-hand smoke but hesitant to inconvenience her party guests, _____, as she was unsure whether to ask people to smoke outside during the party.

dissembled
vacillated
equivocated
disparaged
concurred

Question 8

The literary agent took ___(i)___ at the statement that slush piles are nothing but ___(ii)___; he argued that several major authors, including Stephenie Meyer, Judith Guest, and even Anne Frank, were discovered in such piles of unsolicited, soon-to-be-rejected manuscripts.

Blank (i)	Blank (ii)
gratification	requisitions
accession	dross
umbrage	compendiums

Question 9

While some academics applaud the modernist movement in many universities to treat history and fiction as inherently related fields, there remains a vocal group of traditional historians and literary critics who ___(i)___ such ___(ii)___ worldview and insist that the ___(iii)___ nature of the two disciplines must be inviolate.

Blank (i)	Blank (ii)	Blank (iii)
venerate	a dogmatic	separate
deride	an axiomatic	logical
celebrate	a heretical	intertwined

Question 10

Adventures of Huckleberry Finn was one of the first major American novels to be written in _____ voice, using the unaffected language of the common person describing everyday events.

an erudite
a reticent
an urbane
a quotidian
a quixotic

Question 11

The question of when, if ever, history can be considered ___(i)___ is contentious, to say the least. One could argue, for example, that any evaluation of the 180-year-old presidency of Andrew Jackson would likely be ___(ii)___ the controversies that define evaluations of more contemporaneous political leaders, and yet a plethora of passionately held views continues to polarize. The ___(iii)___ of any one judgment is perhaps the one certainty surrounding the issue.

Blank (i)	Blank (ii)	Blank (iii)
apolitical	characteristic of	objectivity
tendentious	free from	mellifluousness
unexpurgated	mired in	subjectivity

Question 12

The ___(i)___ state of the city’s public schools certainly demands immediate attention, but it is important that our remedies be thoughtful and comprehensive. While appropriate measures of teacher performance and subsequent accountability will undoubtedly play a vital role in revitalizing our schools, it would be ___(ii)___ the many other factors at play, factors as widely divergent as the system’s deteriorating physical capital and students’ home lives. Even the most talented teachers are challenged, for example, to ___(iii)___ of an unstable or abusive home environment on a student’s ability to learn.

Blank (i)	Blank (ii)	Blank (iii)
execrable	an error to neglect	terminate the ability
tendentious	a solution to ignore	mitigate the effects
transient	a panacea to solve	exacerbate the influence

Question 13

With his relentless energy but equally diminutive attention span, Garlin ___(i)___ his talents on several potentially exciting but uncompleted projects, much to the dismay of his friends who, while venerating his enthusiasm, ___(ii)___ his unfocused nature.

Blank (i)	Blank (ii)
squandered	impugned
evinced	parried
burnished	defalcated

Question 14

The origins of La Tomatina, an annual Spanish event in which participants hurl overripe tomatoes at one another for up to two hours, are ____, with possible theories including a friendly food fight and a volley aimed at a bad musician.

esoteric
ephemeral
apposite
nebulous
ubiquitous

Question 15

The ____ group in the adjoining room made it difficult for students taking the mid-term examination to concentrate.

obstreperous
quiescent
rapacious
enervated
antagonistic

DRILL 4

Directions: For each blank select one entry from the corresponding column of choices. Fill all blanks in the way that best completes the text.

Question 1

Susan ____ the theater; she bought tickets for all the shows put on by the local drama group.

abhorred
cherished
owned
loathed
managed

Question 2

The so-called “thieves’ cant” was a __ (i) __ language created by thieves, beggars, and swindlers in England in the 1530s to allow them to communicate without the authorities knowing what was going on. Although the cant was widely used by criminal subcultures five hundred years ago, it is now mostly __ (ii) __, found only in literature and fantasy role-playing games.

Blank (i)	Blank (ii)
clandestine	obsolete
bourgeois	pervasive
sacrilegious	contemporary

Question 3

Currently ____ in philately, Roger decided to pursue his new hobby because he had already become an expert numismatist.

a dilettante
a philanderer
a mentor
a specialist
an eccentric

Question 4

While the __ (i) __ structures of Lego projects are often impressive, it’s the internal __ (ii) __ such as flower pots, sink fixtures, and working windows that make them truly magical.

Blank (i)	Blank (ii)
august	minutiae
external	stratagems
incidental	proboscises

Question 5

Prior to taking on the new invader, the defending army had engaged in arduous combat; it is likely that the ____ resulting from waging two battles in two days played a part in its subsequent defeat.

bellicosity
pugnacity
pacification
enervation
aggravation

Question 6

Often considered one of the best films in cinematic history, Breakfast at Tiffany’s faced several __ (i) __ during production. The film’s star, Audrey Hepburn, almost refused the part, afraid it would __ (ii) __ her pristine image; further, the film faced intense scrutiny

from censors, and the director had to make several compromises to ___(iii)___ them.

Blank (i)	Blank (ii)	Blank (iii)
complications	augment	assuage
harbingers	tarnish	refute
advancements	peruse	discomfit

Question 7

The ___(i)___ of medieval papal power was the pontificate of Innocent III, whose immense personal prestige cowed monarchs from the powerful Philip II “Augustus” of France to the ___(ii)___ John of England, who earned such derisive epithets as “Lackland” and “Softsword.” Even before Innocent’s tenure, though, the involvement of Pope Henry IV in the Investiture Conflict had begun to hint at the tension between spiritual and ___(iii)___ leadership that would eventually boil over in the Protestant Reformation.

Blank (i)	Blank (ii)	Blank (iii)
zenith	feckless	archaic
perigee	intemperate	temporal
antipathy	resplendent	consecrated

Question 8

Ironically, the myth of Martin Van Buren’s _____ was due largely to circumstances that had little to do with Van Buren himself; in reality, of all the U.S. presidents since Andrew Jackson, Van Buren exceeded the average in education, intellect, and experience.

profundity
stoicism
mediocrity
aptitude
malleability

Question 9

Some argue that profiting from terrible suffering by publishing photographic books about natural disasters is shameless ___(i)___, but perhaps the practice has the ___(ii)___ effect of helping us to appreciate the humanity of people living far way.

Blank (i)	Blank (ii)
presumptuous	salutary
idolatrous	specious
profiteering	sedulous

Question 10

While she may have answered him truthfully—in the strictest sense of the word—it became clear to Sergei after the incident that Sheryl had actually been trying to _____.

vituperate
obfuscate
illuminate
covet
desiccate

Question 11

Certainly a roundabout narrative, the book—much like the others in the author’s pseudo-autobiographical series—proved to be unpopular among those who preferred _____ to loquaciousness.

succinctness
enlargement
garrulousness
gregariousness
perspicacity

Question 12

During training to handle ___(i)___ arguments, the students on the debate team practiced techniques for quickly coming up with remarks that were ___(ii)___ even when they might know very little about the topic and would have only a few minutes to prepare.

Blank (i)	Blank (ii)
spurious	sanctimonious
extemporaneous	germane
contentious	seditious

Question 13

Although they stood with the congressman in a tenuous display of solidarity, the incensed commissioners could not conceal their _____.

camaraderie
rancor
adulation
facetiousness
hubris

Question 14

The ___(i)___ with which the second-string quarterback managed to turn the tide of the game shocked even those who were familiar with his skills. Previously, he was more infamous for his deceitful ___(ii)___ off the field than for anything he had accomplished with a ball in his hand, but his immediate impact on the decisive game is likely to turn some of his erstwhile doubters into ___(iii)___ fans.

Blank (i)	Blank (ii)	Blank (iii)
indolence	petulance	recumbent
alacrity	chicanery	ardent
probity	recidivism	fetid

Question 15

The magazine article was ___(i)___ about the police commissioner’s accomplishments. Although some lawyers’ groups argued against the appropriateness of his tactics, the double-digit drop in the crime rate since his appointment suggests that all the journalist’s praise was ___(ii)___.

Blank (i)	Blank (ii)
effusive	specious
tentative	presumptuous
bombastic	apposite

DRILL 5

Directions: For each blank select one entry from the corresponding column of choices. Fill all blanks in the way that best completes the text.

Question 1

Rich found the chance shift in the path of the storm ____(i)__, as he was hoping to use the excuse of heavy weather to ____(ii)__ more much needed time. With the deadline ____(iii)__ and his credibility on the line, he will have to find a way to get the presentation done.

Blank (i)	Blank (ii)	Blank (iii)
hilarious	deplete	deferred
disappointing	garner	nigh
successful	refuse	audacious

Question 2

The defense attorney's ____ closing statement was not enough to sway the jurors in his client's favor; stirring words could not conceal the defendant's evident guilt.

deceptive
eloquent
lengthy
crafty
impromptu

Question 3

A recent Harris Poll indicated that many professions have seen a decline in their ____(i)__ over the past several years; teaching, in contrast, has ____(ii)__ more respect over the same time period.

Blank (i)	Blank (ii)
ranks	reflected
prestige	squandered
fortunes	reaped

Question 4

In 1770s colonial New England, Puritans ____ the celebration of Christmas, which they considered to be an odious reminder of the Pope's tyranny.

placated
extolled
circumscribed
tempered
repudiated

Question 5

The ____(i)__ lining of an eggshell is ____(ii)__, and this is the reason using salt water to boil an egg can make the egg taste salty. For the same reason, it is important not to store eggs in the refrigerator with uncovered, strong-smelling food items since the scents can ____(iii)__ the egg, causing it to taste bad.

Blank (i)	Blank (ii)	Blank (iii)
yolk	impermeable	permeate
membrane	flexible	addle
albumen	porous	infect

Question 6

Many dog owners treat their pets too ____, forgetting that canines have evolved in competitive environments in which emotional

aggressively
quixotically
fortuitously
indulgently
belligerently

Question 7

As part of Marina Abramovičs groundbreaking exhibition at the Museum of Modern Art in New York City, the artist herself logged 700 hours over the course of 3 months in a small chair. Visitors were invited to sit across from the performance artist's stolid countenance, for whatever ___(i)___ they desired, the ___(ii)___ sitting for only a few moments and the bold sitting for several hours; the visitors thus became ___(iii)___ components of the piece, wittingly or unwittingly.

Blank (i)	Blank (ii)	Blank (iii)
motive	irresolute	integral
tenure	boorish	culpable
approbation	genial	nascent

Question 8

Repulsed by ____ employees, the executive informed his staff that he preferred constructive criticism to calculated flattery.

natty
profligate
rapacious
sententious
obsequious

Question 9

Students may consider modernist works such as James Joyce's *Finnegan's Wake* to be more ____ than Victorian prose: Victorian narratives are linear and predictable, while Joyce's tortuous plots are fragmented and fickle, and they confound the reader.

banal
recondite
elegiac
mundane
panegyric

Question 10

It struck Professor Steele as ___(i)___ that the eighteenth-century Bavarians devoted such effort to building houses of worship because at the same time, the rest of Europe's religious fervor was ___(ii)___, while movements such as nihilism gained steam.

Blank (i)	Blank (ii)
felicitous	weltering
anomalous	forswearing
querulous	dissipating

Question 11

Ancient generals, lacking modern technologies such as radio and satellite communication, often found that one of the most significant challenges in warfare was accurate ____ of the myriad of changes on the battlefield or in the campaign.

fortification
adulteration
appraisal
accretion
adumbration

Question 12

In psychological literature, the “sleeper effect” refers to the phenomenon in which a persuasive message from a trustworthy source loses ____ over time, while the efficacy of a message from a less credible source simultaneously increases.

prescience
erudition
evasiveness
control
cogency

Question 13

Pundits do not believe that the sporadic calls for her ouster—outcries spurred by both her unusual lifestyle and social policies—have compelled the monarch to seriously consider ____.

abnegation
vacillation
castigation
asceticism
misanthropy

Question 14

For some time, scientists refused to believe that Earth’s continents are made of moving tectonic plates. Physicists, who could not devise a theory to explain the now-accepted process, rejected the theory outright, as did geologists, who were far too __(i)__ in their thinking, thereby __(ii)__ the advancement of science for a time.

Blank (i)	Blank (ii)
officious	checking
assiduous	limning
dogmatic	asseverating

Question 15

E.L. Doctorow argues that the role of artists in the 21st century is to provide a reminder that even in __(i)__ world, one thing is __(ii)__: America will always be a nation of __(iii)__ free expression.

Blank (i)	Blank (ii)	Blank (iii)
an arcadian	egregious	unfettered
an idiosyncratic	autonomous	circumscribed
a volatile	immutable	jingoistic

DRILL 6

Directions: For each blank select one entry from the corresponding column of choices. Fill all blanks in the way that best completes the text.

Question 1

Dolly Madison, the wife of President James Madison, was known especially for her ____, remaining calm even as the British invaded Washington D.C. during the War of 1812.

impracticality
cynicism
equanimity
zeal
malevolence

Question 2

Seth was extremely ____, and did not enjoy activities that required effort to meet new people.

extroverted
introverted
gregarious
lackluster
jaded

Question 3

Though Denise's colleagues occasionally took the distant look on her face to mean that she was __(i)__, she was actually thoroughly __(ii)__ of what was happening in the office at all times.

Blank (i)	Blank (ii)
truant	insensible
oblivious	sedulous
fetching	cognizant

Question 4

Some religious leaders have declared inaction on environmental issues to be ____, because it may now be considered a sin to pollute the earth.

fathomable
splenetic
iniquitous
diaphanous
dilatory

Question 5

Because he ate high-calorie snacks while riding the exercise bike, Julie ridiculed DeRay's workout philosophy as ____.

fatuous
pithy
indolent
hackneyed
precarious

Question 6

Marty could not help but view the glass as half-empty: for example, when the economy turned around and jobs began to __(i)__, Marty insisted to all who would listen that the good news would be quite transient, that another recession was __(ii)__, and that

those who doubted him would later appreciate his unwillingness to celebrate.

Blank (i)	Blank (ii)
proliferate	superfluous
aggrandize	imminent
pique	odious

Question 7

The recent convert, still a ____ with respect to the rites of her church, did not yet feel completely comfortable in her new faith.

pilgrim
iconoclast
ascetic
tyro
poseur

Question 8

Veeder claims that the very notion of the existence of synonyms is __ (i) __, as words depend on __ (ii) __, connotation, and linguistic and cultural context for their __ (iii) __ meanings.

Blank (i)	Blank (ii)	Blank (iii)
veracious	denotation	subjective
fallacious	cogitation	distinct
maladaptive	mastication	interchangeable

Question 9

Politicians' tendency to __ (i) __ their own virtues by demeaning their opponents is __ (ii) __: what if voters forget the name of the candidate and remember only that of his adversary?

Blank (i)	Blank (ii)
enfeeble	injudicious
tout	ostentatious
democratize	apt

Question 10

Video game enthusiasts know that, while the astounding advances in technological innovation might increase the level of fun of the gaming experience, such a result is by no means ____.

desultory
endemic
salient
ineluctable
seminal

Question 11

Middlemarch author George Eliot reportedly bemoaned the dearth of __ (i) __ women, of which her well-educated main character, Dorothea, was a __ (ii) __. Therefore, Eliot scholars have long debated the author's meaning in marrying Dorothea to the elderly preacher Casaubon and having him exploit his bride for __ (iii) __ needs.

Blank (i)	Blank (ii)	Blank (iii)
captious	paradigm	menial
erudite	misogynist	clerical
venal	chimera	nebulous

Dismissed by the establishment, professing nothing but disdain for the canon, and yet beloved by his followers who trumpet his _____ opinions, the raffish pundit is laughing all the way to the bank.

iconoclastic
blithe
inveterate
meretricious
meritless

Question 13

The 1966 opening of the relatively expansive Grace Memorial Bridge signaled a ____(i)___ improvement in highway safety in the low country of South Carolina; the old bridge had been ____(ii)___ narrow, creating a ____(iii)___ driving experience for traders and tourists alike.

Blank (i)	Blank (ii)	Blank (iii)
prodigious	insufficiently	malodorous
subsidiary	meagerly	cantankerous
radiant	precariously	perilous

Question 14

Sarah Grand's short story, "The Tenor and the Boy" was a ____(i)___ account of her popular novel The Heavenly Twins, for it was published years before the novel was completed. Unlike the novel's characters, who were drawn in rich detail, the short story contained mere ____(ii)___ caricatures.

Blank (i)	Blank (ii)
fallow	fractious
parochial	dynamic
nascent	unbedizened

Question 15

One might sometimes wonder whether some of the stories passed down through generations are veritable or ____(i)___; whether the heroes had such endless mettle or were, in their hearts, occasionally ____(ii)___; and whether the denizens of the times described were really so ____(ii)___, or were perhaps tinged with a bit of guile.

Blank (i)	Blank (ii)	Blank (iii)
heretical	pusillanimous	halcyon
jejune	arrant	ingenuous
apocryphal	insouciant	piquant

DRILL 7

Directions: For each blank select one entry from the corresponding column of choices. Fill all blanks in the way that best completes the text.

Question 1

Although his latest project was relatively ____ —little more than a few basic plot points scribbled on a napkin—the veteran screenwriter easily sold the story to a major Hollywood studio.

undeveloped
polished
convoluted
prosaic
tortuous

Question 2

Despite being located in hot and sunny California, San Francisco is famous for its ____ weather, engendered by the confluence of two different meteorological systems in the Bay Area.

stimulating
adverse
balmy
appealing
duplicitous

Question 3

Possessing few natural resources upon its newly-granted independence in 1863, Singapore remained economically ____ until an influx of industrialization and foreign investment took hold there.

powerful
prosperous
solvent
fortuitous
dubious

Question 4

Wealth and technology wrought by industrialization gave nations in the northern hemisphere strategic ____(i)__. This included sophisticated weaponry that could easily overpower the more ____(ii)__ arms held by the countries of the southern hemisphere.

Blank (i)	Blank (ii)
adoration	intricate
advantage	perilous
consequence	rudimentary

Question 5

Even though legislators claimed the Contagious Diseases Acts strengthened the nation, social purists argued the Acts ____ the nation's moral growth by encouraging licentious behavior.

advanced
ameliorated
hampered
supplanted
enhanced

The new lecture hall's ____ design reflected the architect's minimalist influences.

posh
intricate
unadorned
refulgent
grandiose

Question 7

Bentham provided the conceptual model for modern prisons, though not the actual structural model. In Bentham's ____(i)__, a central watchtower provided a ____(ii)__ view of all subjects under surveillance, theoretically allowing the guard to observe all of their actions; the tower, however, was structured in such a way that the subjects being observed could not see the guard. This meant that the prisoners were forced to assume that they were being ____(iii)__, even when the guard was off-duty, allowing prison administrators to be economical in their employment of guards.

Blank (i)	Blank (ii)	Blank (iii)
schematic	constricted	castigated
epitome	panoramic	scrutinized
quintessence	salubrious	exonerated

Question 8

The grave accusations made by the plaintiff were almost entirely ____(i)__ the testimony of two witnesses. Therefore, when the court ____(ii)__ the credentials of those witnesses, the plaintiff's case disintegrated, and the relevant claims were shown to be ____(iii)__.

Blank (i)	Blank (ii)	Blank (iii)
subservient to	vindicated	facetious
isolated from	repudiated	unerring
dependent on	debated	specious

Question 9

Modern tennis fans have come to realize that, although, quantum technological leaps in racquet technology have lead to ____ increases in the speed and power with which players can hit the ball, this has not necessarily lead to a more entertaining game.

innocuous
halcyon
malleable
commensurate
tractable

Question 10

Many Major League Baseball relief pitchers choose an electrifying theme song to play as they take the mound; the song ____ their fans and instills fear in their opponents.

eviscerates
enervates
assuages
innervates
pervades

Question 11

Emmet Ray, a fictional jazz guitarist in Woody Allen's film Sweet and Lowdown, is a paradoxical character; while he displays sophisticated musical artistry, his personality is typically ____.

petulant
elegant
audacious
maladroit
multi-faceted

Question 12

The editorial, though intended to ___(i)___ the current administration, inadvertently ___(ii)___ several claims made against the regime suggested as a preferable alternative, effectively ___(iii)___ any plans for a change in leadership.

Blank (i)	Blank (ii)	Blank (iii)
impugn	attenuated	politicizing
bolster	substantiated	metamorphosing
venerate	benighted	castrating

Question 13

Humans have a natural affinity for Vervet monkeys; in both their habits and their personalities, they remind us of the essential humanity of non-human creatures. Vervet monkeys, like most humans, are ___(i)___, conducting most of their activities during the day. Their ___(ii)___ behavior and desire for company shows us that humans are not the only species that values ___(iii)___.

Blank (i)	Blank (ii)	Blank (iii)
quotidian	collaborative	litheness
circadian	gregarious	camaraderie
diurnal	egregious	fatuity

Question 14

A mathematician should not automatically reject theorems that might at first seem witless or juvenile; advanced degrees are not a license for ___(i)___, nor do they ___(ii)___ arrogance or egotism.

Blank (i)	Blank (ii)
haughtiness	sanction
puerility	dispel
substantiation	cultivate

Question 15

Bettelheim's ___(i)___ of "Hansel and Gretel" is thorough and well-researched, but ultimately not compelling due to his ___(ii)___ focus, which is severely constricted by his narrow worldview.

Blank (i)	Blank (ii)
incantation	parochial
exegesis	sweeping
relish	jaundiced

ANSWERS

Drill 1

1. E
2. initiative, strive
3. remote, collaboration
4. B
5. distinction between, interchangeably
6. B
7. anomalies, daunting, authoritative
8. C
9. E
10. A
11. despondency, elation, euphoric
12. glut, belied
13. pecuniary, panacea
14. B
15. timorous, precarious, suspect

Drill 2

1. A
2. D
3. chronically, agile
4. D
5. belligerent, corporeal, epithets
6. bucolic, cultural
7. C
8. glib, exacerbating, parlous
9. expatiate, petty, impending
10. esteem, accolades
11. inerrancy, doctrine
12. bellicose, diatribes, magnanimous
13. pilloried, deride
14. E
15. B

Drill 3

1. D
2. silences, falsely
3. C
4. tact, denigrating
5. E
6. precluded, pragmatic
7. B
8. umbrage, dross
9. deride, heretical, separate
10. D
11. apolitical, free from, subjectivity
12. execrable, an error to neglect, mitigate the effect
13. squandered, impugned
14. D
15. A

Drill 4

1. B
2. clandestine, obsolete
3. A
4. external, minutiae
5. D
6. complications, tarnish, assuage
7. zenith, feckless, temporal
8. C
9. profiteering, salutary
10. B
11. A
12. extemporaneous, germane
13. B
14. alacrity, chicanery, ardent
15. effusive, apposite

Drill 5

1. disappointing, garner, nigh
2. B
3. prestige, reaped
4. E
5. membrane, porous, permeate
6. D
7. tenure, irresolute, integral
8. E
9. B
10. anomalous, dissipating
11. C
12. E
13. A
14. dogmatic, checking
15. volatile, immutable, unfettered

Drill 6

1. C
2. B
3. oblivious, cognizant
4. iniquitous
5. A
6. proliferate, imminent
7. D
8. fallacious, denotation, distinct
9. tout, injudicious
10. D
11. erudite, paradigm, menial
12. A
13. prodigious, precariously, perilous
14. nascent, unbedizened
15. apocryphal, pusillanimous, ingenuous

Drill 7

1. A
2. B
3. E
4. advantage, rudimentary
5. C
6. C
7. schematic, panoramic, scrutinized
8. dependent on, repudiated, specious
9. D
10. D
11. D
12. impugn, substantiated, castrating
13. diurnal, gregarious, camaraderie
14. haughtiness, sanction
15. exegesis, parochial

Drill 1

1. E If you notice the same direction trigger so too, you can recycle the clue personalities for the blank. None of initiations, implementations, or rationalizations means personalities, so eliminate choices (A), (B), and (D). Although aptitudes means skills, which pets can have, it does not directly relate to the clue in the sentence, personalities. So eliminate choice (C), and select choice (E).
2. initiative and strive
 Lisa is frustrated by her husband's lack of something, so that something must be good. Lassitude is the quality of being lazy or lacking in energy, which is not a good quality. Eloquence, or being skilled in the use of language is a positive quality, but the lack of eloquence would not likely be something that a wife would find frustrating. Initiative means ambition, a positive quality for a person to have. To motivate a person who lacks initiative, one must encourage him to try to do things. To mitigate means to make a problem better, which isn't quite what you're looking for. To invigorate means to give life to something, and there's no indication in the sentence that the husband is expected to give life to anything. To strive means to aim for; a person with a lack of initiative should try to aim for things, so this word is a good fit for the blank.
3. remote and corroboration
 The astronomers have discovered objects at the edges of the universe, so you need a word that is consistent with that clue. Paranormal means beyond the scope of scientific understanding; it is usually used to describe supernatural things like aliens and ghosts. Viscous means fluid or sticky, so that word is definitely not consistent with the blank. Remote means distant, which would describe objects at the edges of the universe. The quasars have shown scientists something about the existence of stars, so blank (ii) must mean something like proof. Distortion means changing, so that word is not consistent with the blank. Intuition is a feeling that something is true, but not actual proof. Corroboration means proof, and so it is a good fit for blank (ii).
4. B With the opposite direction trigger but in fact, you can recycle the opposite of the descriptive clue much less well-known, by filling the blank with well-known. None of contingent, cogent, or insistent means well-known, so eliminate choices (C), (D), and (E). Infamous means well-known, but in a negative way, so eliminate choice (A). Renowned means well-known, so select choice (B).
5. distinction between and interchangeably
 For the first blank, the clues difference and has become unimportant require something like difference between. Similarity of and usefulness of do not mean difference between; distinction between does. For the second blank, the opposite-direction trigger but and the clue difference require something like similar. Statistically and differentially do not mean similar, but interchangeably does. Select distinction between and interchangeably.
6. B The clue is that Klemfuss created Secretaries' Day, so he must have appreciated the value and significance of administrative assistants. None of proscribed, refuted, undermined, or admonished means appreciated, so eliminate choices (A), (C), (D), and (E). Although touted does not—strictly speaking—mean appreciated, a person touts only something that is appreciated, so select choice (B).
7. anomalies, daunting, and authoritative
 For the first blank, recycle the clue differences. Of the choices, only anomalies means differences. The second blank relates how these differences affect the task of literary scholars, so a word like difficult or challenging would make sense. Of the choices, only daunting makes sense. The third blank describes the type of texts that such differences would make so challenging, so a word that means genuine or authentic would make sense. Of the choices, authoritative is the best fit.
8. C The clue is the CD is similar to the painting, so you can fill the blank with something like reminds people of. None of obfuscates, disenchant, or sanctions means reminds people of, so eliminate choices (B), (D), and (E). Although the designer of the CD may admire the painting, the CD itself does not. Moreover, admires does not mean reminds people of. Evokes means reminds people of, so eliminate choice (A) and select choice (C).
9. E Despite the use of the word although, the structure of this sentence, including the colon, makes clear that you need a word that goes in the same direction as the clue. Whether you look to known or the phrase after the colon (or both), the blank must mean something like recognized. None of relegated, abrogated, annulled, or criticized means recognized, so eliminate choices (A), (B), (C), and (D). Someone who is positively recognized for something would be apotheosized, so select choice (E).
10. A With the opposite-direction trigger though, and the clue that Dan wanted honest criticism, the blank can mean something like yes-men. None of pedants, benefactors, adversaries, or mavericks means yes-men, so eliminate choices (B), (C), (D), and (E). Sycophants means yes-men, so select choice (A).
11. despondency, elation, and euphoric
 The third blank has the clearest clue, so start there: The trigger although indicates that you need a word to contrast disappointed, so you need something like happy. Of the choices, only euphoric means happy. The third blank also provides part of the clue for the first two blanks: They'll describe a strange mix of emotions, and they'll be parallel to disappointed and euphoric. Of the choices for the first blank, only despondency matches disappointed; of the choices for the second blank, only elation matches euphoric.
12. glut and belied

The sentence states that sequels and remakes are derivative, and thus the article would be decrying their existence. Eliminate dearth, which means scarcity. Also eliminate quality as too neutral a word. Glut means overabundance and correctly reflects the clue word flooding. Next, a large quantity of sequels decades ago would disprove the claim at the end of the sentence. Eliminate underscored and predicted because neither one is supported. Belied means disproved, making glut and belied the final answers.

13. pecuniary and panacea

For the first blank, the information regarding the type of resources that were expended are the clues financial albatross and bankrupted. Thus, the first blank must mean something like financial. Assiduous and wholesome do not mean financial; pecuniary does. For the second blank, you learn that the drug is supposed to be used to treat numerous physical and mental ailments. Thus, the second blank must mean something like cure-all. Sinecure and mendicant do not mean cure-all, but panacea does. Thus, select pecuniary and panacea.

14. B Recycle the clue that Sheila made what seemed like bitter complaints. None of to waffle, dissemble, or mince mean to make bitter complaints, so eliminate choices (A), (C), and (E). You might have associated grieve with the word grievance, but it actually means to mourn, so eliminate choice (D). To rail is to make bitter complaints, so select choice (B).

15. timorous, precarious, and suspect

Because the stress tests are supposed to reassure the investors, the first blank must describe someone in need of reassurance, so something like scared or nervous would make sense; timorous is the best match. The second blank describes financial institutions that are distinguished from reliable ones, so the word for that blank should contrast with reliable. Of the choices, precarious offers the best contrast. Finally, the results are reported with a lack of candor, so the test results should be dishonest or unreliable. Suspect is the best choice.

1. A Recycle the clue bickering. None of laudations, affectations, procrastinations, or humor mean bickering, so eliminate choices (B), (C), (D), and (E). To squabble means to bicker, so select choice (A).
2. D The clues that the Mayor was involved in a long trial and as a result suffered failing health require that the blank mean something like sick. None of distraught, exonerated, inspired, or vindicated mean sick, so eliminate choices (A), (B), (C), and (E). Debilitated means sick, so select choice (D).
3. chronically and agile

The sentence starts with the trigger word Despite to set up a contrast between the two parts of the sentence. Since the first part describes her poor physical condition and the second her surprisingly positive state, the first blank has to describe her arthritis in a negative way. Mildly and sympathetically would not present the arthritis negatively, so the best answer is chronically. Similarly, the clue to the second blank is pleasant and it implies that the dog is positively described. Enervated means lacking energy, and acute could means perceptive, which also does not make sense here. Thus the best answers are chronically and agile.

4. D The clue that the goal is to prevent breaking the shell requires that the blank mean something like strong. None of tenuous, pristine, permeable, or obtuse mean strong, so eliminate choices (A), (B), (C), and (E). Resilient means strong, so select choice (D).
5. belligerent, corporeal, and epithets

Start with the third blank: You need something that can be yelled, and can't be stopped with handcuffs, so a word like insults would make sense in the blank. Of the choices, only epithets means insults. The second blank should contrast with the third blank, and describe the type of violence that can be stopped with handcuffs. Hence, you need a word like physical; of the choices, corporeal is the best fit. Finally, the first blank should mean something like fighting, since you know the two men are handcuffed and have been engaging in physical violence. Belligerent is the best choice.

6. bucolic and cultural

The sentence starts with the trigger word Though, signaling that the two parts of the sentence will be different. Since you know the town is scenically beautiful, the second blank means something else besides its appearance. Eliminate attractive, and eliminate picaresque because there is no clue that the town refers to an adventure story. Cultural makes the most sense for the meaning of the second blank. The first blank describes the scenically beautiful town, and must mean something similar to attractive country as a contrast to the city. Eliminate sprawling and desolate, neither of which are suggested by the clues. Bucolic, which means pertaining to country pleasantness, is the strongest fit. The best answers are bucolic and cultural.

7. C Recycle the clue dominion. None of heterodoxy, methodology, impotence, or timorousness means dominion, so eliminate choices (A), (B), (D), and (E). Hegemony means dominion, so select choice (C).
8. glib, exacerbating, and parlous

The clues for the first blank indicate that the chairman's comments made the people even angrier; you can eliminate compassionate and solicitous, because people would not be angered by kind or helpful comments. Glib is the best choice. For the second blank, you need something like making worse, because you know that the people are even angrier; exacerbating is the best fit. The third blank describes the situation that was made worse, so it must have already been bad. Of the choices, only parlous, which means perilous, is sufficiently negative.

9. expatiate, petty, and impending

The clue to the last blank is next month, so the missing word must mean coming or about to happen. Impending is the best match, and neither of the two other choices is supported. For the first blank, the clue is that the memoir allows distinguished figures to tell us about experiences and wisdom learned, so the missing word must mean write about. Extemporize means to improvise, which is incorrect because Grant wrote an actual account, and exagitate is incorrect because there is no suggestion of his stirring up or censuring. Expatiate, which means to write about in detail, is the best fit. For the second blank, note the contrast between the significant works of distinguished figures and the experience of a fly-by-night internet celebrity. The missing word will mean insignificant. Apocryphal is incorrect because the writings are not necessarily fictional, and eccentric is incorrect because there's no context to support the experiences being unusual. That leaves petty, which fits the context of the sentence.

10. esteem and accolades

For the first blank, the opposite-direction triggers although and not cancel each other out, so you can recycle the clue honored. Neither decorum nor ennui means honor, but esteem does. For the second blank, the semicolon trigger indicates than an explanation will be given about how Father's Day became an honored tradition. Ask yourself what was required from prominent figures before Americans embraced the holiday. The second blank must mean something like praise. Neither opprobrium nor hyperbole means praise, but accolades means praise. Thus, select esteem and accolades.

11. inerrancy and doctrine

For the first blank, the clue is that the conservatives' belief deals with the Scripture never being wrong, suggesting the missing word means perfection or infallibility. Fallacy is the opposite of what you need, and interpretation also does not mean infallibility. That makes inerrancy the best answer for the first blank. For the second blank, the trigger word However signals a different interpretation of the meaning of the missing word. Erudition, or scholarly knowledge, can be eliminated, and centurion is irrelevant

to the clues and blank. The right answer is doctrine, which means belief.

12. bellicose, diatribes, and magnanimous

First, find the story. Here is the funeral of a mean, judgmental man. The speaker respectfully finds nice things to say about him. For the first blank, look for things that go with arrogant and bitterly critical. Only bellicose, meaning aggressive and hostile, is sufficiently negative. The second blank describes the actions of the guy, so we need something along the same lines. Although eulogies belong at funerals, we need something bad. Diatribes work. The last sentence changes the direction by starting with nevertheless so we need something positive. Only magnanimous is positive.

13. pilloried and deride

Start with the first blank because it is easier. The clue disruptive child tells you the mother probably punished the child. Touted would provide you with a sentence that was opposite in meaning and calumniated has a similar negative connotation, but it would not be appropriate. The second blank's clue mock can be recycled for the blank. Laud is opposite of mock, and renege simply doesn't make sense. Select pilloried and deride.

14. E The same direction trigger provided by the colon and indeed, and the clue that some people have never even seen a live chicken or cow requires that the blank mean something like absence. None of pith, dross, surfeit, or dirge mean absence, so eliminate choices (A), (B), (C), and (D). Dearth does mean absence, so select choice (E).

15. B The same direction trigger as and the clues hoax and feigned require that the blank mean something like tricked. None of reconnoitered, lambasted, vitiated, or derided mean tricked, so eliminate choices (A), (C), (D), and (E). Hoodwinked does mean tricked, so select choice (B).

1. D The same-direction semi-colon and the clues that an aloe plant is an excellent choice for someone who lacks time for frequent watering or careful maintenance requires that the blank mean something like thrive. None of facilitate, ingest, consume, or advance means thrive, so eliminate choices (A), (B), (C), and (E). Flourish means thrive, so select choice (D).
2. silences and falsely
The word in the first blank gives a false impression about Howard's underlying gregariousness, so you need something that suggests he isn't sociable; hence, silences is the best choice. Since Howard is, underneath it all, gregarious, new acquaintances who think him churlish are incorrect, so falsely is the best fit.
3. C Recycle the clue peaceful pasture for the blank. None of halcyon, perennial, eclectic, or quiescent mean relating to a peaceful pasture, so eliminate choices (A), (B), (D), and (E). Bucolic does mean relating to a peaceful pasture, so select choice (C).
4. tact and denigrating
The first blank refers to what Jill doesn't have, so you need a word that means politeness. Of the choices, only tact fits. The second blank refers to what Jill does without meaning to, so you need a word that means insulting. Of the choices, only denigrating means insulting.
5. E The same-direction trigger and as well as the clue nothing but contempt requires that the blank mean something like disrespectfully. None of didactically, affably, jocularly, or morosely means disrespectfully, so eliminate choices (A), (B), (C), and (D). Disdainfully does mean disrespectfully, so select choice (E).
6. precluded and pragmatic
The council member's strategy made her opponent's attacks impossible or useless, so you need a word for the first blank that means something like made impossible. Of the choices, only precluded makes sense. The second blank is a description of the strategy in opposition to a less effective one, so a word like effective or useful would make sense. Of the choices, only pragmatic, which means practical, fits.
7. B Lindsay is described as hesitant and unsure, and is weighing the conflicting motivations of health and convenience, so you need a word that means something like hesitated or was unsure. Of the choices, only vacillated makes sense. Be careful of choice (C): To support equivocated, you would have to know that Lindsay had already spoken to guests about the issue.
8. umbrage and dross
Start with the second blank. You know from the second part of the sentence that slush piles are unsolicited, soon-to-be-rejected manuscripts, so the missing word is probably something like unwanted material. Of the choices, only dross is sufficiently negative. For the first blank, since the agent is arguing that several major authors were discovered in the pile, he must not like the idea of the slush pile being called dross. The missing word, then, must mean something like offense. Of the choices, only umbrage means offense.
9. deride, heretical, and separate
For the first blank, the opposite-direction trigger while and the contrast between the clues modernist and traditional require that the blank mean something like criticize. Venerate and celebrate do not mean criticize, but deride does. For the second blank, the clue traditional as well as the completed first blank require that the second blank mean something like radical. Dogmatic and axiomatic do not mean radical, but heretical does. For the third blank, the opposite direction trigger while and the clue inherently related require that the blank mean something like distinct. Logical and intertwined do not mean distinct, but separate does. Thus, select deride, heretical, and separate.
10. D To describe the voice of the novel, recycle any of the clues unaffected, common, or everyday. Of the choices, only quotidian makes sense.
11. apolitical, free from, and subjectivity
This is a tricky passage. It talks about the controversies that surround history. It seems that even old history can still get people riled up and there are bound to be opposing views. As always, pay attention to trigger words. The second sentence says, and yet there are lots of different views. This is a change in direction, so one would think there would only be one view. So the second blank should say something like past or over. Free from works the best. Since everything is being argued, we need something negative or argumentative for the last blank. That knocks out mellifluousness and objectivity. The first blank speculates on whether or not historical arguments are ever over. Apolitical is the best stand-in for the end of arguments over history.
12. execrable, an error to neglect, and mitigate the effects
The first blank describes the state of the city's public schools; since the author is seeking remedies, something like bad would make sense in the blank. Of the choices, only execrable means bad. The second sentence lists elements that will play a vital role in the remedy, but the trigger while suggests more needs to be done; of the choices for the second blank, only an error to ignore allows this meaning. The final sentence is an example to reinforce this idea, and the blank describes what talented teachers would do to negative factors; of the choices, only mitigate the effects makes sense.
13. squandered and impugned

For the first blank, the clues that Garlin has a diminutive attention span and uncompleted projects require a word that means something like wasted. Evinced and burnished do not mean wasted, but squandered does. For the second blank, the opposite direction trigger while and the clue venerating require a strong word such as scorned. Parried and defalcated do not mean scorned, but impugned does. Thus, select squandered and impugned.

14. D The clues origins and the entire phrase following the comma requires that the blank mean something like uncertain. None of esoteric, ephemeral, apposite, or ubiquitous means uncertain, so eliminate choices (A), (B), (C), and (E). Nebulous means mysterious which is close enough to unknown, so select choice (D).
15. A The clue made concentrating difficult requires that the blank mean something like noisy. None of quiescent, rapacious, enervated, or antagonistic means noisy, so eliminate choices (B), (C), (D), and (E). Obstreperous means noisy, so select choice (A).

1. B The same-direction semi-colon trigger and the clue bought tickets for all the show require that the blank mean something like loved. None of abhorred, owned, loathed, or managed means loved, so eliminate choices (A), (C), (D), and (E). Cherished means loved, so select choice (B).
2. clandestine and obsolete
The clue for the first blank is that the language was created so the criminals could communicate without the authorities knowing what was going on. Thus, the missing word must mean something like secret. Of the choices, only clandestine fits. The clue for the second blank is that the language was widely used by criminals five hundred years ago, but the trigger although means you need a word that means the opposite of widely used. Of the choices, only obsolete makes sense.
3. A Even if you do not know the words philately and numismatist, the clue is new hobby, with yet additional information provided by the opposite-direction time trigger had already become and associated clue expert. Therefore, the blank must mean something like amateur. None of philanderer, mentor, specialist, or eccentric means amateur, so eliminate choices (B), (C), (D), and (E). Dilettante means amateur, so select choice (A).
4. external and minutiae
Start with the second blank, which refers to little things inside the structures: flower pots, sink fixtures, and working windows. The word in the blank, then, must mean something like details. Of the choices, only minutiae makes sense. Now work the first blank: The trigger while suggests you need a word that means the opposite of internal minutiae. Of the choices, external is the best fit. While august might be tempting, it's too strong for the context: While the structures are important, there isn't any indication that they're inspiring reverence.
5. D The same-direction semi-colon trigger and the clues arduous combat, two battles in two days and subsequent defeat require that the blank mean something like exhaustion. None of bellicosity, pugnacity, pacification, or aggravation means exhaustion, so eliminate choices (A), (B), (C), and (E). Enervation means weakening, so select choice (D).
6. complications, tarnish, and assuage
For the first blank, you need a word that explains what happened during production. Audrey Hepburn almost refused the part and the director had to make several compromises, so a word like problems would make sense. Of the choices, only complications fits. The second blank describes what Hepburn feared would happen to her image; if she nearly turned down the part because her image was pristine, she didn't want to hurt her image. Of the choices, only tarnish can mean hurt. The last blank describes why the director made compromises for the censors: to make them happy. Of the choices, only assuage makes sense.
7. zenith, feckless, and temporal
The first blank refers to state of papal power under Innocent; since his immense personal prestige cowed even kings, a word that means something like high point or greatest period would make sense in the blank. Of the choices, only zenith works. The second blank refers to John of England. Both the trigger from ... to and the epithets given to John indicate that you need a word that contrasts with powerful. Of the answer choices, only feckless, which means ineffective, fits. The third blank needs to contrast with spiritual: Don't be fooled by the word and, which is part of the change direction trigger tension between ... and. Temporal is the only choice that makes sense.
8. C The clue ironically indicates that the blank needs to mean the opposite of exceeded the average in education, intellect, and experience, so your answer could be anything that suggests uneducated, unintelligent, or inexperienced. Of the choices, only mediocrity makes sense.
9. profiteering and salutary
The sentence talks about books that make money from publishing other people's disasters. This is often what profiteering means. For the second blank, the clue helping us to appreciate the humanity of people requires a word meaning something like helpful. Specious and sedulous do not mean helpful, but salutary does. Thus, select profiteering and salutary.
10. B The opposite-direction trigger while and the opposite-direction time trigger after the incident, along with the clue answered him truthfully require that the second blank mean something like mislead. None of vituperate, illuminate, covet, or desiccate mean mislead, so eliminate choices (A), (C), (D), and (E). Obfuscate does mean mislead, so select choice (B).
11. A The words unpopular and preferred act as opposite-direction triggers. The clues roundabout and loquaciousness require that the blank mean something like briefness. None of enlargement, garrulousness, gregariousness, or perspicacity means brevity, so eliminate choices (B), (C), (D), and (E). Succinctness does mean brevity, so select choice (A).
12. extemporaneous and germane
The students will have only a few minutes to prepare, so you need a word for the first blank that means improvised. Spurious means inauthentic, and can be eliminated. Contentious means tending to argue and does not address the lack of time to prepare, so eliminate this choice. Extemporaneous means with little or no preparation and is the best fit and correct answer. For the second blank, you need a word that means effectively on topic because their remarks have to be effective though they might know very little about the topic. Sanctimonious means showing moral superiority and seditious means inciting a rebellion, so eliminate these choices. Germane means relevant and is the best fit for the second blank.

13. B The opposite-direction trigger although and the clue tenuous display of solidarity indicate that the remainder of the sentence will explain that the solidarity is not heartfelt. Thus, the clue incensed requires that the blank mean something like anger. None of camaraderie, adulation, facetiousness, or hubris means anger, so eliminate choices (A), (C), (D), and (E). Rancor does mean anger, so select choice (B).

14. alacrity, chicanery, and ardent

The second-string quarterback doesn't seem to have played much, but is well known off the field for something infamous or deceitful. For the second blank, chicanery fits the bill nicely. For the first blank, we know he turned the tide of the game and did it in a manner that surprised everyone. Alacrity will work for this blank since we are told that his impact was immediate. And for the third blank, winning a decisive game is likely to win him some passionate fans, so ardent works well.

15. effusive and apposite

For the first blank, you need a word that means expressing praise, since the journalist is giving praise at the end of the sentence. Effusive means unrestrained in expressing praise; this is the best fit and correct answer. Tentative means holding back and is not a match, and bombastic means pompous and is also incorrect. Since the crime rate has dropped, you need a word that means appropriate for the second blank. Specious means seeming true but actually false; eliminate this choice. Presumptuous means based on assumption, and is incorrect given the proven drop in crime rate. Apposite means appropriate; this fits the context of the blank and is the correct answer.

1. disappointing, garner, and nigh
 Rich has a deadline approaching and needs some more time. The storm would have given him a good excuse, but it seems to have changed direction. Its shift, therefore, must have been dis-appointing to him. He planned to use the excuse to buy himself some more time, so garner works in the second blank. The third blank describes the deadline, which is approaching, so nigh works well.
2. B The clues stirring words and not enough require that the blank mean something like eloquent. None of deceptive, lengthy, crafty, or impromptu means eloquent, so eliminate choices (A), (C), (D), and (E), and select choice (B).
3. prestige and reaped
 The two parts of the sentence need to refer to the same topic, so recycle the clue respect for the first blank. Of the choices, only prestige means respect. For the second blank, the clue decline and the trigger in contrast to indicate that you need a word that means something like increased. Of the choices, only reaped makes sense.
4. E The clue odious reminder requires that the blank mean rejected. None of placated, extolled, circumscribed, or tempered mean rejected, so eliminate choices (A), (B), (C), and (D). Repudiated does mean rejected, so select choice (E).
5. membrane, porous, and permeate
 For the first blank, you need a word for the tissue right on the inside of an eggshell. Yolk is the central part of the egg, so eliminate this choice. Albumen is the egg white, but this does not line the eggshell; eliminate this choice. Membrane is the word meaning the tissue that separates parts of an organism, and is the best fit. For the second blank, you need a word that states the membrane lets things get through. Impermeable means blocks from passage, the opposite of what you need. Flexible does not mean allowing to pass through, so eliminate this choice. Porous is the best choice. For the third blank, you need a word that means enter, and the correct choice, permeate, means exactly that. Addle means to confuse and infect means to cause to become ill, and neither choice fits the context of the third blank.
6. D The same-direction trigger too and the clue emotional coddling (and the opposite-direction trigger forgetting and its clue competitive environments) require that the blank mean something like leniently. None of aggressively, quixotically, fortuitously, or belligerently mean leniently, so eliminate choices (A), (B), (C), and (E). Indulgently does mean leniently, so select choice (D).
7. tenure, irresolute, and integral
 The second blank has the strongest clue, so start there. The people who sit for only a few moments are contrasted with the bold who sit for several hours, so you need a word that means not bold. Of the choices, only irresolute fits. Now go to the first blank: If some are described as sitting only briefly, and others for longer periods, then something that means period of time would make sense. Of the choices, only tenure can mean period of time. The third blank refers to the role the visitors play; since the visitors themselves are half of the performance, you might use a word like necessary to describe what kind of components they are. Integral is another word for necessary, so it's the best fit.
8. E The clues repulsed by and calculated flattery require that the blank means something like flattering. None of natty, profligate, rapacious, nor sententious means flattering, so eliminate choices (A), (B), (C), and (D). Obsequious means flattering, so select choice (E).
9. B The same-direction trigger colon and the clues tortuous and confound require that the blank mean something like complex. None of banal, elegiac, mundane, or panegyric means complex, so eliminate choices (A), (C), (D), and (E). Recondite does mean complex, so select choice (B).
10. anomalous and dissipating
 For the first blank, the clue is the contrast established between Bavaria and the rest of Europe. Thus, the blank must mean something like weird. Felicitous and querulous do not mean weird, but anomalous does. For the second blank, the opposite-direction trigger while, and the clue gained steam require a word meaning something like diminishing. Weltering and forswearing do not mean diminishing, but dissipating does. Thus, select anomalous and dissipating.
11. C The clues lacking radio and satellite, significant challenges, and changes on the battlefield require that the blank mean something like information about. None of fortification, adulteration, accretion, or adumbration of means information, so eliminate choices (A), (B), (D), and (E). Appraisal means review or evaluation, so choice (C) is the best answer.
12. E The trigger while indicates that the two parts of the sentence will disagree, and the opposition is expressed by loses and increases. Thus, the blank needs to mean effectiveness of a persuasive message. Of the choices, only cogency conveys this sense of a convincingly logical message.
13. A The clue oyster requires that the blank mean something like resignation. None of vacillation, castigation, asceticism, or misanthropy means resignation, so eliminate choices (B), (C), (D), and (E). Abnegation means resignation of the throne, so select choice (A).
14. dogmatic and checking
 The first blank describes the thinking of scientists who refused to consider a process they can't explain, so a word like rigid or limited makes sense. Of the choices, only dogmatic matches the meaning you need. The second blank describes the result of such

limited thinking on the advancement of science, so you need a word that means something like slowing or stopping. Of the choices, only checking fits the context.

15. volatile, immutable, and unfettered

The third blank must be consistent with the clue free expression. Circumscribed means restricted and would disagree with free expression. Jingoistic means extremely nationalistic and has a negative connotation. Unfettered means without restriction, making it the best choice for the third blank. If America will always have a particular characteristic, then that characteristic must be always true. Egregious means extremely bad, and autonomous means self-governing, so neither of those words is a good fit for the blank. Immutable means unchanging and is your best choice. The trigger even in tells you that the first blank must go in a different direction from the second blank, and that you need a word that indicates changing. Arcadian means peacefully rustic, and idiosyncratic means strange; neither of these words means changing and both choices can be eliminated. Volatile means prone to change, and is a good contrast to immutable.

1. C Recycle the clue remaining calm. None of impracticality, cynicism, zeal, or malevolence means remaining calm, so eliminate choices (A), (B), (D), and (E). Equanimity means remaining calm, so select choice (C).
2. B The clue that Seth did not enjoy activities that required effort to meet new people requires that the blank mean something like shy. None of extroverted, gregarious, lackluster, or jaded mean shy, so eliminate choices (A), (C), (D), and (E). Introverted means shy, so select choice (B).
3. oblivious and cognizant
 If Denise looks distant, it appears that she is unaware of her surroundings. Truant means absent, which makes no sense in this text, and fetching means attractive, which is also irrelevant. Her distant look makes her appear oblivious, or unaware. The word actually signals that the second blank must go in a different direction from the first, and must mean something such as aware. Sedulous means hardworking, which has nothing to do with being aware. Insensible means unaware, and is the opposite of what you're looking for. Cognizant means aware, and is the best fit for the second blank.
4. iniquitous
 The same-direction trigger because and the clue sin indicate that the blank means sinful. Of the choices, only iniquitous means sinful and is the best answer.
5. A The clue ridiculed, as well as the idea of eating snacks while working out, requires that the blank mean something like foolish. None of pithy, indolent, precarious, or hackneyed means foolish, so eliminate choices (B), (C), (D), and (E). Fatuous means foolish, so select choice (A).
6. proliferate and imminent
 The clue the economy turned around and the trigger word and dictate that the blank, which refers to what happened to jobs, must mean something like increase or become more common. Of the choices, only proliferate makes sense. Be careful with aggrandize—it means to make something greater, not to become more numerous. To agree with the clue the good news would be quite transient, the second blank has to mean something like about to happen. Of the choices, only imminent fits.
7. D You are told the subject is new and doesn't yet feel comfortable. For the blank, you need something to support the notion that she is new. Tyro means a beginner, so it fits nicely.
8. fallacious, denotation, and distinct
 Veeder thinks something about synonyms, words that mean the same thing. Meaning for him seems to depend upon context and connotation as much as an actual dictionary definition, which would make the notion of synonyms difficult since there would always be external circumstances to consider. Therefore, we need something negative for the first blank at least. That knocks out veracious. Maladaptive doesn't make sense since nothing is adapting, so fallacious must work. For the second blank we need things that contribute to the meanings of words. Only denotation works. And for the last blank, we need something that says that even synonyms are different. Distinct fits the bill.
9. tout and injudicious
 A politician emphasizes his virtues, and so the first blank must mean emphasize. To enfeeble is to weaken, the opposite of what you need. To democratize is to make democratic, and doesn't mean emphasize. To tout is to emphasize the positive nature of something, and is consistent with the context of the first blank. The clue after the colon refers to a negative consequence of the politicians' actions, so the second blank must be a negative word. Apt means smart and is a positive word you can eliminate. Injudicious and jejune are both negative words. Injudicious means unwise and ostentatious means pretentiously showy. Injudicious is a better fit for the blank: The problem with the politicians emphasizing their own virtues is that it is ineffective and ill-advised.
10. D The opposite-direction trigger while and the clue might require that the blank mean something like inevitable. None of desultory, endemic, salient, or seminal means inevitable, so eliminate choices (A), (B), (C), and (E). Ineluctable means inevitable, so select choice (D).
11. erudite, paradigm, and menial
 The first and third blanks have the clearest clues, so start with them. For the first blank, recycle the clue well-educated; of the choices, only erudite makes sense. For the third blank, recycle the clue mundane; of the choices, only menial fits. The second blank describes Dorothea, and if her marriage into a life of mundane and menial needs causes debate among Eliot scholars, then Dorothea must have been an example of a well-educated, erudite woman. Of the choices, only paradigm means example.
12. A Here is a guy who no one in the establishment takes seriously and yet has an exuberant following. His opinions must not match with the mainstream. Iconoclastic is the best fit.
13. prodigious, precariously, and perilous
 The clues are the same for the second and third blanks, so start there. The new bridge was an improvement in highway safety, so the old bridge must have been a danger; of the choices, only precariously makes sense in the second blank, and only perilous makes sense in the third. The first blank describes the improvement: the old bridge had been narrow, and the new one was relatively expansive. so

a word that means big would make sense. Of the choices, only prodigious means big.

14. nascent and unbedizened

The trigger word unlike and the clue drawn with rich detail require that the second blank means lacking detail. Dynamic and fractious do not mean lacking detail, and can be eliminated. Unbedizened means unadorned and is a good fit for this blank. For the first blank, the clue years before the novel was complete and the information later on indicate that the first blank means incomplete. Parochial means narrow-minded and fallow means inactive, so both can be eliminated. Nascent means coming into existence and is the best choice for the first blank.

15. apocryphal, pusillanimous, and ingenuous

Each blank is associated with the opposite direction trigger or. For the first blank, the clue veritable requires a word that means untrue. Of the choices, only apocryphal makes sense. For the second blank, the clue mettle requires a word that means cowardly. Of the choices, pusillanimous is the best fit. For the third blank, the clue guile requires a word meaning something such as guileless. Of the choices, only ingenuous means guileless.

1. A The missing word refers to a project—in this case a screenwriter’s story—which consists of little more than a few basic plot points. Therefore, the missing word might mean something like incomplete, so you can immediately eliminate choice (B). There is not enough information to suggest that the story is convoluted, prosaic, or tortuous, so eliminate choices (C), (D), and (E). Undeveloped means incomplete, so choice (A) is the best answer.
2. B The blank describes the weather in San Francisco. Thanks to the trigger, we know it is not hot and sunny. We also know that it comes from opposing weather systems. We need something that is both bad and refers to opposition. Adverse works perfectly.
3. E From the clues in this sentence, you know that Singapore’s independence was newly-granted and that industrialization and foreign investment had not yet taken root. You need a word that means something like unstable or weak for the blank. Choices (A), (B), and (C) all go in the opposite direction of what you’re looking for, so eliminate them. Fortuitous doesn’t fit in the context of your clues, making dubious the best answer.
4. advantage and rudimentary
 The clue to the second blank, sophisticated weaponry that could easily overpower, suggests a word that means less sophisticated. Intricate and perilous do not pertain to being less sophisticated and can be eliminated, leaving rudimentary as the correct answer. The northern nations could easily overpower the southern nations, and so they had an upper hand. Advantage is the only choice that means upper hand and is correct.
5. C While the legislators claimed the Contagious Diseases Acts strengthened the nation, the change- direction trigger even though shows that the social purists disagreed. You want a word similar to harm or weaken for the blank. Hampered is similar to harm and provides you with an equivalent sentence; advanced and enhanced go in the opposite direction, so eliminate choices (A) and (E). Ameliorated and supplanted don’t make sense in the context of the sentence, so eliminate choices (B) and (D) and select choice (C).
6. C The hall’s design was likely plain or functional, given the clue minimalist influences. Choices (A), (B), and (E) are easy eliminations, as they are clearly opposite in meaning. You can eliminate choice (D) if you know that refulgent is the opposite of plain. Unadorned is the best match.
7. schematic, panoramic, and scrutinized
 Recycle the phrase conceptual model for the first blank. Of the choices, schematic is the best fit; both epitome and quintessence can mean model, but in the sense of a perfect example of something. The second blank describes the view, which allows the guard to observe all, so you need something that means showing everything; of the choices, only panoramic, which means offering a wide view, makes sense. The third blank describes what’s being done to the prisoners, so recycle the clue observed. Of the choices, only scrutinized means observed.
8. dependent on, repudiated, and specious
 Start with the last blank because it is the easiest. The clue tells you that the plaintiff’s case disintegrated. Therefore, the claims must have been shown to be false. Facetious, though somewhat negative, does not mean false but does not go far enough. Unerring goes in the opposite direction. Specious is the best match. The first blank is the easiest one to attempt next. The case fell apart when something happened to the witnesses’ credentials, so a good phrase for the first blank—which described the role of the witnesses in the plaintiff’s case—is “based on.” Dependent on is the only match. If the plaintiff’s claims were based on the witnesses, and the case fell apart, logically the witnesses must have been discredited somehow. A good word for the second blank—which describes what the court decided about the witnesses’ credentials—is denied. Vindicated goes in the opposite direction. Repudiated is the best match.
9. D The sentence states that increases in technology have led to increases in speed and power. The blank, therefore, requires something along the lines of similar or proportional. Only commensurate fits. The answer is choice (D).
10. D Look for the clue in the strong adjective electrifying. The song must pump up the pitchers’ fans. Eviscerates and enervates are the opposite of what you want, so eliminate choices (A) and (B). Pervades is unrelated to the clue, and assuages sounds like a possibility, but has nothing to do with excitement; eliminate choices (C) and (E). You’re left with choice (D), innervates, which means to pump up.
11. D The blank refers to Emmet Ray’s paradoxical character. The trigger while follows the clue, indicating that his sophisticated musical artistry is contrary to some other aspect of his personality. Look for a word that means unsophisticated, and use POE to eliminate choices (B) and (E). Petulant and audacious have appropriately negative meanings, but are unrelated to sophistication in the context of artistry. Maladroit means clumsy, so choice (D) is the best match.
12. impugn, substantiated, and castrating
 The first blank refers to the intention of the editorial, which suggested a preferable alternative to the current administration; a good word to describe the editorial’s intention toward the incumbents might be a word such as attack or undermine. Of the choices, only impugn means attack. The second blank refers to claims made against the group that the editorial was trying to support; the actions were inadvertent, so a good word for the blank might be something like supported or proved. Of the choices, the only word that makes sense is substantiated. Since the editorial ended up damaging the interests of the preferable alternative, a good word for the third blank might be something like stopping. Castrating matches this meaning.

The clue for the first blank is most of their activities during the day, and so that blank must describe such a pattern. Quotidian means common and circadian patterns occur once per day, but not specifically during the daytime. Diurnal is the best fit because it means during the daytime. The second blank needs to be consistent with the clue desire for company. Collaborative means enjoys working with others but not a desire for company, but a gregarious creature is quite social and seeks out company. Egregious means extremely bad, and does not match. The third blank must also describe something like company. Liteness means grace and flexibility and fatuity means idiotic, and neither one truly refers to having company. Camaraderie means trusting friendship, which is the most like company and makes it the best answer.

14. haughtiness and sanction

The first part of the sentence states that mathematicians should not be dismissive of theorems that seem beneath them. Someone who does this would be snobbish, so the first blank must mean something like snobbishness. Puerility means immaturity and substantiation means proof, so neither of those is a match, while haughtiness does mean snobbishness. If the advanced degrees are not a license, that means that they do not give someone permission to do something bad such as have arrogance or egotism. The second blank must mean something like permit. To dispel is to push away, which is almost the opposite of what you need here. To cultivate means to foster, which is not the same as permit. Sanction is the best answer because one of its standard definitions is give permission.

15. exegesis and parochial

Bettelheim has produced something that is thorough and well-researched concerning "Hansel and Gretel." The first blank must then mean scholarly study. An incantation is a magical spell and relish could mean enjoyment, but neither word pertains to being scholarly. An exegesis is a critical explanation, or scholarly study, and is correct. Bettelheim's focus is severely constricted by his narrow worldview, so it must be narrow. Sweeping can mean vast, the opposite of what you need. A jaundiced focus is one that is affected by envy or bitterness, and there is no support for this idea in the clues. Parochial means provincial or narrow-minded, making it a solid fit for the second blank.

Reading Comprehension



Reading Comp vs. Text Completions and Sentence Equivalence

On any CAT test there are always trade-offs between speed and accuracy. Nowhere is this truer than Reading Comprehension. Reading Comprehension is an open-book test. In theory, with unlimited time, you should never get an RC question wrong. The first step to improving performance on Reading Comprehension questions, therefore, is to find that time. By improving your speed and efficiency with Text Completion and Sentence Equivalence questions, you leave yourself more time to spend on Reading Comprehension. When you become a master of the other two question types, you free yourself up to relax and take your time on RC where time equals points.

Question Types

There are three types of questions you might see with Reading Comprehension:

1. Multiple Choice
2. Select All That Apply
3. Select In Passage

Multiple Choice

These are the standard, five choice, multiple-choice questions we have been doing. There is only one correct answer choice and four wrong ones.

Select All That Apply

These are a variation of the old roman numeral questions. Remember the ones that gave you three statements marked I, II, and III, and the answer choices that said, “I only,” “I and II only,” “I, II, and III”? These are the same, but without the answer choices. They will give you three statements, with a box next to each. You have to select all that apply. The process is the same. Find lead words and look for proof.

Select In Passage

In this case, ETS will ask you to select a sentence in the passage that makes a particular point, raises a question, provides proof, or some other function. These questions will appear primarily on short passages. If one appears on a longer passage, they will limit the scope to a particular paragraph. Again, the same rules apply. Pick a lead word. Put the question in your own words, and use Process of Elimination. To answer one of these, you will literally click on a particular sentence in the passage or paragraph.

How Much to Read

Reading Comprehension is the most time-intensive portion of the Verbal test. Deciding how much time to allocate to the passage is another way to pick up valuable time without sacrificing accuracy. The amount of time you devote will depend upon four primary factors. They are Difficulty Level, Length, Skill Set, and Number of Questions.

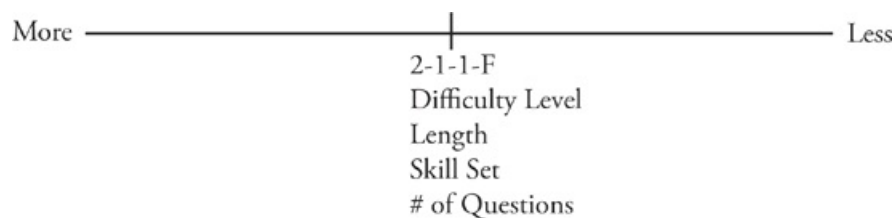

RULES TO LIVE BY: You can always read more IF you have to, but you never want to read more THAN you have to.

Difficulty Level

Always, you want to take the easy test first. There is an enormous range in the difficulty level of the different passages you will see. There is no law that says that you have to do the questions in the order in which they are given. If you come across a particularly impenetrable question—and you’ll know pretty quickly if you do—just skip it and leave it for the end.

Length

Passages on the GRE come in two lengths: those that fit on a screen and those that force you to scroll. Scrolling is a nuisance. If the passage is so short that it fits on one screen, you might as well just read it. You’ll probably end up reading the whole thing anyway.

Skill Set

Some people can skim, some cannot. Which are you? Can you skim quickly and still pick up the main idea of a passage? Or, when you skim do you either miss the main idea or get sucked into the details? If you are inclined to get sucked in, you will get sucked in, and you shouldn’t try to skim at all. Use 2-1-1-F instead. If you are not sure, try a couple of test passages out of the Practicing to Take the GRE General Test, www.ZTCprep.com

Number of Questions

The test will tell you how many questions are associated with a particular passage. If the next two or three questions are based upon the same passage, it's worth your time to read more of it.

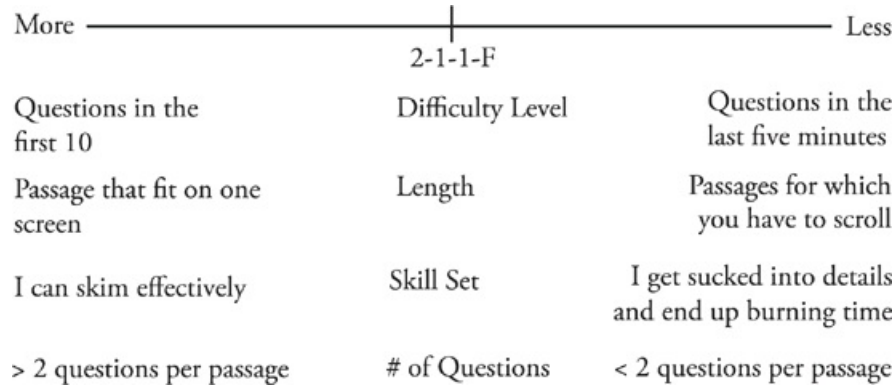

(Click [here](#) to view a larger image.)

Strategy

You can always read more if you need to, but you don't ever want to read more than you have to in order to answer a particular question. If you see a short passage with two questions in the first ten, you should read the whole thing. If you see a long passage with one question in the last few minutes, and you have more questions to get to, just bubble in and move on. For anything else, you will need a moderated approach. A great place to start is 2-1-1-F. This means that you read the first sentence of the passage, the first sentence of each additional paragraph, and the last sentence of the passage. This should be sufficient to get the GIST of the passage. Remember, if you need to read more, you always can.

Basic Question Approach

If you get a Reading Comprehension question wrong, it is for one of the three reasons. Either you misread something in the passage, misread the question, or misread one of the answer choices. The basic approach is designed to give some rigor to your interaction with each of these main components.

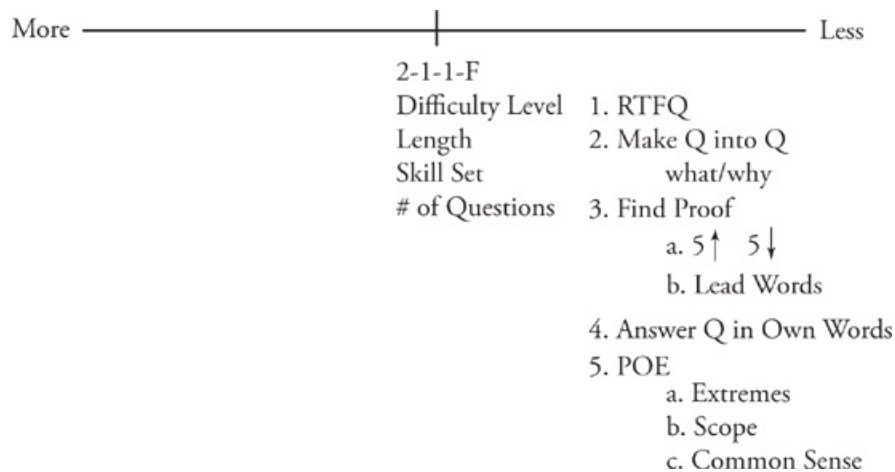

(Click [here](#) to view a larger image.)

Read the Question (RTQ)

The first thing to do, naturally, is to read the question. Specifically, you should put your finger or pencil literally on the screen and read the question word for word. Misreading the question is one of the most common causes of errors. Reading with a pencil or finger, word for word, is a good habit, especially for strong readers who tend to skip over words without even noticing.

Turn the Question into a Question

After a few hours of testing, it is all too easy for the eyes to glaze over and to read without really comprehending. To ensure that the words aren't simply going in one eyeball and out the other, you will want to engage in the question in a qualitative way. Most questions, you will notice, aren't really questions at all. They are incomplete sentences. The easiest way to own the question is to actually make it back into a question. The easiest way to do this is to simply start with the word "What" or "Why," and then to let the rest follow (any question-word will do, but the vast majority of questions either ask "What was stated in the passage?" or "Why was it said?").

Never attempt to answer a question from memory. The minute you stop reading you start forgetting. ETS counts on this and plays with the answer choices to change your recollection of the information. You must look at the information in context, but you don't have to read the whole paragraph. Choose a word from the question that will be easy to find in the passage, skim for it, and then read five lines above it to five lines below it. That should be sufficient to answer the question.

Answer the Question in Your Own Words

Before you get to the answer choices, stop and answer the question in your own words. When you do this, you will know exactly what you are looking for in the answer choices. With your own answer choice in mind, you will be protected from the tricks and traps that ETS has laid for you with theirs. After turning the question into a question, this is the most frequently blown off step; they are both among the most important. If you have followed steps 1 through 4, typically, one answer choice will look correct and the other four will look ridiculous. This is precisely the position you want.

POE: THE ANSWER CHOICES

There are three general characteristics that separate correct answers from incorrect ones. As you work through the drills, note these types whenever you see them. Over time you will develop an instinct for right versus wrong answers.

Extremes

ETS plays it safe. Correct answers are wishy-washy or very difficult to prove false. It is too easy to find exceptions to extreme answer choices. For this reason, they are almost never correct. Remember, to ETS it doesn't matter what the passages says. They don't write the passages, but they do write the questions and the answers. They can choose to word correct or incorrect answers any way they like. They choose to do it in a way that won't put them on the phone with dozens of experts in various fields who beg to differ with them.

Examples

(A)	Disproving the view that herbivores are less intelligent than carnivores	Can this even be done? <i>Prove</i> or <i>disprove</i> is a very extreme word.
(B)	Chaucer was the first English author to focus on society as a whole as well as on individual characters.	This is too definitive a statement for a subjective view.
(C)	The public is not interested in increasing its awareness of the advantages and disadvantages of nuclear fusion power.	Really? Says who? The whole of the public?

Scope

If you can not physically put your finger on a specific word, line, phrase, or sentence that proves that your answer choice is correct, you cannot choose it. ETS loves to add to answer choices little bits and bobs that were never stated in the passage. If a passage is about a recent immigrant's first experience of America, ETS will widen the scope of an answer choice to include all immigrants. If the passage is about the existence of heavy metals on some planets, an incorrect answer choice will talk about all planets.

Examples

MAIN IDEA OF PASSAGE	OUT-OF-SCOPE ANSWER CHOICE
How new plant seeds got to Hawaii	1. Resolving a dispute about the adaptability of plant seeds to bird transport
	2. Refute the claim that Hawaiian flora evolved independently from flora in other parts of the world
	3. Why more varieties of plant seeds adapted to external rather than to internal bird transport

1. Resolving a dispute is an awfully strong opening verb for this answer choice, but this answer choice is all about the nature of seeds, not about how seeds got to Hawaii. If the passage is about Hawaii, then the correct answer had better say “Hawaii.”
2. The question is talking about Hawaii and seed transport, not about other parts of the world and evolution.
3. Again, this one is all about seeds and adaptation, not about Hawaii and transportation.

Common Sense

Many of the answer choices simply don't make any sense. Just because you see it on the GRE doesn't mean you have to take it seriously. Science passages may have answer choices that are highly illogical or physically impossible. Humanities passages may have answer choices that support different or even opposite views than those of the author, and certainly ones that ETS could never stand behind. And some answer choices are just downright ridiculous.

(A)	The public has been deliberately misinformed about the advantages and disadvantages of nuclear power.	The GRE is not your typical forum for exposing government cover-ups.
(B)	An interpretation of a novel should primarily consider those elements of novelistic construction of which the author of the novel was aware.	Unless someone can call up dead novelists from the grave, exactly how is the good critic to know which elements of novelistic construction the authors were aware of?
(C)	James, more than any other novelist, was aware of the difficulties of novelistic construction.	Extreme language aside, are there measurable degrees of awareness? Do we know how aware every novelist in history is or was? Is James really the Michael Jordan of Awareness of Novelistic Construction?

RULES TO LIVE BY: If you cannot physically put your finger on a specific word, line, phrase, or sentence that proves that your answer choice is correct, you cannot pick it.

POE: THE PROCESS

In general, you want to be doing, not thinking. Thinking gets you into trouble. The best way to tell if you are thinking rather than doing is to pay attention to your hands. If your hands are not moving, you are either spacing out, lost, or attempting to do work in your head—all are bad. The use of scratch paper, therefore, is as critical to the Verbal portion as it is to the math. Proper use of the scratch paper will help you stay on track, organize your thinking, and maintain an efficient, meticulous, and systematic approach.

The Process of POE is, in essence, a two-pass approach. In the first pass, walk through the answer choices asking a simple question: Maybe or Gone? “Gone” refers to the answer choice can be eliminated with confidence; “maybe” refers to everything else. This pass should take no more than 15 seconds. You are not looking for the correct answer. On this pass, you don't want to invest a lot of time in any one answer choice, because often the correct answer will be very clear, or you will be able to eliminate the other four. Remember that you have already found proof and answered the question in your own words. Correct and incorrect answer choices should leap out at you at this point. Only if you are left with two or three do you need to investigate further.

Make sure that you park your thinking on the page as you go; otherwise you are doing two separate jobs. One is assessing the answer choices; the other is keeping track of what you've already decided about prior answer choices. This is confusing and inefficient. It is much better to simply park it on the page.

To do this you can use three basic symbols.

- ~~(A)~~ WRONG
- ✓ (B) LOOKS GOOD
- ⚡ (C) MAYBE OR DON'T KNOW
- (D)
- (E)

“Wrong” means that it is clearly wrong and therefore gone. You never need to spend any time on this answer choice again. “Maybe” simply means that it is possible or you're not sure. “Yes” means that it looks good. You are making these assessments through a combination of information you have acquired in the passage, and the three elimination techniques listed above. In the last ten, you might even stop here if you have two “maybes” or a clear winner. In the first ten questions, you must go back to the passage to find proof.

First Pass

Main Idea:
Pros and cons of a unified assessment of the two halves of *Wuthering Heights*

Q: The author of the passage would be most likely to agree that an interpretation of a novel should

- (A) not try to unite heterogeneous elements in the novel
Half of the passage is about why this is a good thing!
- (B) not be inflexible in its treatment of the elements in the novel
Wording is ridiculous, but "be flexible," okay, that makes sense.
- (C) not argue that the complex use of narrators or of timeshifts indicates a sophisticated structure
Umm. Not sure, it's got to stay in for now.
- (D) concentrate on the those recalcitrant elements of the novel that are outside the novel's main structure
No, the author definitely didn't prescribe what someone should or shouldn't concentrate on.
- (E) primarily consider those elements of novelistic construction of which the author of the novel was aware
Common sense.

(Click [here](#) to view a larger image.)

This first pass took about 15–20 seconds. You eliminated some obvious choices and got it down to two. Then, on the second pass, to go back to the passage to check your proof. Paraphrase the remaining answer choices to make sure you are reading them correctly. Remember that there is only one correct answer. If you are absolutely sure that both are correct, you are misreading something. As usual, the correct answer is a clear, if awkward, paraphrase of something stated in the passage (the awkwardness is an obvious attempt to steer us away from this answer choice). The second choice is stated, but it's encouraged, not discouraged.

In the second pass, pay no attention to answer choices (A), (D), or (E) because they have already been eliminated. Occasionally you will end up eliminating all five; only in this case will you go back and reassess an answer choice you have already eliminated.

Second Pass

Passage says: "Rigidity in any interpretation of this or any novel is always a danger." and: "...is encouraged by the novel's sophisticated structure, revealed in its complex use of narrators and time shifts."

Q: The author of the passage would be most likely to agree that an interpretation of a novel should

- (A) not try to unite heterogeneous elements in the novel
Half of the passage is about why this is a good thing!
- (B) not be inflexible in its treatment of the elements in the novel
Wording is ridiculous, but "be flexible," okay, that makes sense. PARAPHRASE!
- (C) not argue that the complex use of narrators or of timeshifts indicates a sophisticated structure
Umm. Not sure, it's got to stay in for now. lead words
- (D) concentrate on the those recalcitrant elements of the novel that are outside the novel's main structure
No, the author definitely didn't prescribe what someone should or shouldn't concentrate on.
- (E) primarily consider those elements of novelistic construction of which the author of the novel was aware
Common sense.

PROOF!

(Click [here](#) to view a larger image.)

To sum up, read only as much as you have to and follow these five steps for all questions:

1. RTQ
2. Make the Question Back into a Question
3. Find Proof
4. Answer the Question in Your Own Words
5. Process of Elimination

There are three things to keep in mind when working on Reading Comprehension:

1. You only need general knowledge of the passage to get started (don't get bogged down in the details).
2. Always answer the question in your own words before you look at the answer choices.
3. Look for reasons why an answer choice is wrong, not reasons why it is right. Park that thinking on your scratch paper. If your hand is not moving, you're stuck. Move on.

Above all: Find proof in the passage for every answer you select. If there's no proof, it's not the right answer.

For a more detailed description and more examples of these techniques, reference *Cracking the New GRE*, 2012 Edition.



Reading Comprehension Drills

Questions 1-2 refer to the following passage.

Little is known about the elusive section of the earth's atmosphere known as the mesosphere. Located between the stratosphere (the maximum altitude that airplanes can achieve) and the thermosphere (the minimum altitude of spacecraft), the mesosphere is poorly understood and little explored. The most significant feature of the mesosphere is the various tides and waves that propagate up from the troposphere and stratosphere. The dissipation of these waves is largely responsible for propelling the mesosphere around the globe. These wave patterns are further affected when gas particles in the mesosphere collide with meteoroids, producing spectacular explosions, which usually generate enough heat to consume the meteor before it can fall to earth. The conflagration leaves behind traces of iron and other metals and fuels the atmospheric tides radiating outward from the mesosphere.

Question 1

The author primarily describes the mesosphere as

- turbulent
- opaque
- unfamiliar
- radiant
- anarchic

Question 2

Consider each of the choices separately and select all that apply.

The passage suggests that the mesosphere is influenced by

- collisions with extraterrestrial debris
- vibrations from the troposphere
- oceanic tides

- Television programming is big business, with sales of interstitial advertising reaching billions of dollars annually. Advertising rates are determined by the viewership of the program in question, which has traditionally been determined by ACNielsen, part of The Nielsen Company. Nielsen wields an immoderate amount of industry clout considering its questionable methods of statistics gathering.
- (5)
- (10) The Nielsen Company relies on selected households to catalog their television watching habits in "diaries." The ratings are then reported as a percentage that indicates the number of viewers watching a television program at a given
- (15) time. The company has come under criticism for choosing residences that underreport daytime and late-night television viewing and for over-representing minorities in sample populations. Critics also point to the nonviable practice of
- (20) measuring how many individuals are watching a given television set and of gauging how attentive the audience is to a program or its advertising.

Question 3

It can be inferred from the passage that the author considers the Nielsen Company's techniques

- intentionally biased
- dubious
- worthless
- unscrupulous
- overly boastful

Question 4

Consider each of the choices separately and select all that apply.

Which of the following does the passage indicate is true of the household members who report their viewing habits?

- Because ratings are reported as a percentage, each household is counted only as one person.
- They are not always accurate when it comes to recording their viewing habits.
- The indirect influence they exert on advertising costs may not be based on all relevant factors.

Although multi-organ transplants have become more common, scientists and surgeons continue to face the ineluctable obstacle of time. Current donor organ preservation times hover around five to six hours. Because of the complicated tissue-matching process, oftentimes organs are unable to reach their beneficiaries, wasting valuable, viable organs. However, scientists are hopeful that a certain substance, called the Hibernation Induction Trigger (HIT), will extend the life of a potential transplant organ.

HIT is an opiate-like substance found in the blood of hibernating animals. Previous experiments have shown that opioids act as an autoperfusion block, preventing blood from flowing through the lymphatic system to organs, a phenomenon known as ischemia. In a preliminary experiment, an infusion of plasma with the Delta opioid delayed hemorrhaging in certain laboratory animals. When this arresting of activity was applied to the transplantation of organs, physicians reported preservation times up to 15 hours, a more than two-fold increase over standard conservation.

Scientists have extrapolated from these findings, further identifying the opioid DADLE as integral to triggering the hibernation process. Infusing HIT-molecule-containing plasma from hibernating woodchucks into canine lungs increased preservation times more than three-fold from previous findings. This experiment suggests that, should a potential donor organ be infused with these trigger molecules before the organ is harvested, the organ would remain transplantable for up to 45 hours, greatly increasing the chance for doctors to find a suitable recipient.

Though these results are exciting, they do nothing to increase survival rates from an organ transplant operation, which currently hover at 60 percent over four years, because patients are still susceptible to infection and rejection. Scientists are a long way from declaring HIT-molecules a safe and consistent method of organ preservation. Still, other areas of science have taken an interest in this research. NASA, for example, is considering the implications of human hibernation for deep space travel.

Question 5

Which of the following can be inferred from the passage?

- Ischemia is essential to the organ transplantation process.
- The same process by which HIT induces hibernation might be applicable to donor organs.
- The biggest obstacle facing physicians in the science of organ transplantation is the difficulty of matching suitable donors and recipients.
- Additional time could be saved by computerizing the tissue-matching process.
- HIT could also be administered to patients awaiting an organ transplant, thereby lengthening the amount of time they are eligible for surgery.

Given the information in the passage about blocking autoperfusion, which of the following could also be true?

- DADLE and HIT must be present in an organ at the same time in order for autoperfusion to be prevented for any length of time.
- If scientists could circumvent the passage of blood through the lymphatic system, organs would cease to deteriorate.
- Scientists are close to developing a method to induce production of HIT in a non-hibernating animal.
- Administering HIT after transplantation is likely to lower the current rates of infection and organ rejection.
- Isolating and infusing opioids may be the key to retarding the progression of decay in transplant organs.

Question 7

The author refers to the experiment with the woodchuck in order to

- illustrate successful preliminary experiments
- suggest genetic similarity between species
- warn that the findings are preliminary at best
- explain why other scientists may be interested in the findings
- suggest the feasibility of inter-species transplant

Question 8

Select the sentence from the passage which suggests how the use of isolated HIT molecules, if they were to be approved for general use, would be limited.

It might seem illogical that the development of modern currency rests on a scientific discovery, but the invention of the "touchstone" allowed ancient societies to create a standard by which valuable metals could be judged. In its most basic form, a touchstone is any dark, finely grained stone upon which soft metals leave traces. When rubbed, a process known as "probing," precious metal alloy cleaves to the stone, leaving a stripe. The color of the stripe (which reveals the percentage of its content that is base metal) can then be compared to a stripe of a known grade of standard alloy. Despite its primitiveness, this probing process allowed merchants to examine alloys quickly and with reasonable certainty. Though civilizations were using gold and silver currencies as early as 500 B.C., coins were easily forged or diluted with less valuable metals, such as tin or lead. The invention and popularization of the touchstone ensured that pure gold and silver could become a standard expression of value.

Question 9

The primary purpose of the passage is to

- demonstrate that science can influence non-scientific progress
- underline the touchstone's importance in the history of currency
- explain how the touchstone is able to measure the purity of an alloy
- explore the etymology of the word "touchstone"
- refute an historical misconception

Question 10

The author's description of how coins were adulterated is included in the passage in order to

- illustrate the historical precedent replaced by the invention
- outline for the reader the chronology of the events in the passage
- explain the larger importance of the details just provided
- give the passage a cultural context
- dismiss a misleading counterargument

Question 11

Consider each of the choices separately and select all that apply.

The passage indicates that the advances brought about by the probing process included

- an efficient means of ascertaining the purity of a metal
- a means by which governments could standardize currency values
- a measure of security against adulterated coins

Women played a substantial role in the furthering of the Polish art song in the late eighteenth and early nineteenth centuries. One notable woman from this time period was Maria Szymanowska, who was both a concert pianist and a composer.

Szymanowska was a member of the Warsaw Music Society who contributed pieces to a cycle entitled Historical Songs. Her songs are by far the most creative and individualistic of the cycle. In addition, Szymanowska composed more than one hundred other pieces, mostly for the piano, including six romances.

Her songs most resemble French romances, and she also employs Polonaise rhythms in two of her songs. In all her works, the melodic line is technically superior. She employs idiomatic keyboard writing, wide chord-spacing, broad cantilenas, and interesting modulations. She also uses the most compelling registers of the instrument and pianistic keys. Her romances are on par with those of Beethoven, Schubert, and Mozart. In fact, Szymanowska was praised by her contemporaries, such as Schumann, who lauded her etudes. Her piano playing was frequently equated to that of Hummel, though Szymanowska's was said to be more ethereal. Thus, she is a progenitor of Chopin in both piano technique and composition.

Female contributors to the development of Polish music have been chiefly ignored. From the meager records which have been preserved, it is incontrovertible that Polish women were, in fact, playing, instructing, and writing music as early as the fifteenth century. However, patriarchal societal structures have precluded adequate documentation about, and preservation of, their work. Unless changes take place, human society will be made poorer for its inability to recognize the expertise and inventiveness of these women.

Question 12

Select the sentence in the third paragraph that gives evidence for the idea that Szymanowska's work laid the foundation for at least one future composer.

Question 13

The author's tone in the final sentence ("Unless changes ... these women") is best described as

- nostalgic
- emphatic
- dismissive
- perplexed
- didactic

Question 14

According to the passage, the musical contributions of Polish women have been neglected due to

- an absence of any documentation of the efforts of female composers

- the male-dominated social order that has existed since at least the fifteenth century
- society willfully ignoring the talent and hard work of female composers
- the fact that people did not realize the genius and creativity of female composers

Question 15

Consider each of the choices separately and select all that apply.

Which of the following can be properly inferred from the passage?

- Szymanowska's advancement of the music of Polish art songs in spite of patriarchal pressure demonstrates her feminist tendencies.
- Szymanowska composed works beyond the genre of the Polonaise that are deserving of praise.
- Szymanowska's works that contributed to the development of Polish art song garnered a disproportionate amount of attention, considering that such compositions were only a small part of her repertoire.

DRILL 2

Questions 1-2 refer to the following passage.

Historically, sociologists have presumed that people will attribute certain characteristics to a member of a particular group when it is generally believed that most members of that group possess the characteristics in question. For sociologists Hepburn and Locksley, such social stereotyping has led to the broader question of whether people are cognizant of their own stereotyping behavior. Seemingly, if one knows that one holds a stereotypical notion such as "all members of a certain ethnic group are natural musicians," then one might also be aware that the notion that "a particular musician of that ethnic group is a great musician" is a corollary of that stereotype. However, people are most aware of their stereotyping when they have no information. When given information that conforms to their beliefs and the individual case observed, people become less aware of their tendency to stereotype and therefore more likely to engage in stereotyping.

Question 1

Which of the following best describes the function of the first sentence?

- To present a criticism of Hepburn and Locksley's conceptualization of why individuals stereotype
- To provide evidence to support Hepburn and Locksley's claims about the problems inherent with stereotyping
- To provide the backdrop for Hepburn and Locksley's study
- To provide an overview of a social phenomenon and its contributions to Hepburn and Locksley's area of inquiry
- To provide a history of social stereotyping alongside Hepburn and Locksley's reservations about the practice

Question 2

The author of the passage is primarily concerned with

- investigations into stereotyping and an awareness of stereotyping by individuals
- an examination of the relative truths behind well known stereotypes
- an attempt to prove that stereotypes are a result of ignorance
- a refutation of a broader question surrounding stereotypes
- a detailed list of when individuals are likely to be aware that they are applying stereotypes

The literature of the American West ranges from lowbrow entertainment to great works of fiction. The extremes are obvious enough, but the middle tends to blur. The dime-store Western never aspired to be anything but entertainment. James Fenimore Cooper and Willa Cather, however, used themes of westward expansion in works clearly intended as highbrow literature. The novels of modern writer Larry McMurtry broke new ground: He took the Western and created a great piece of fiction, without changing its fundamental genre appeal or its accessibility to the general reader.

As an example of his retooling of the Western genre, consider McMurtry's themes. While the Western myth is fundamentally about resettlement to new lands, McMurtry's novels combine elements of the Western myth with less traditional motifs: profound reluctance to face change, conflict between urbanization and the Western ideal, the importance of place, and the role of the land itself. While the traditional Western is rooted in the past, McMurtry's themes combine nostalgia for that past with a sense of emptiness in the present and hopelessness for the future.

Or consider McMurtry's treatment of character. The traditional Western formula depicts mainly masculine characters and portrays them as both heroic and human. In his novels, McMurtry creates strong female characters, transmuting the conventional plot of the trials and dangers of the frontier by folding in deeper ideological insights. Critics rightly credit his novels with reshaping the Western genre, praising his work and its meticulous attention to the Western *mise en scène* as a subversive but sincere tribute to the American West.

Question 3

Select the sentence that shows the author's view of McMurtry's treatment of gender.

Question 4

The author refers to James Fenimore Cooper and Willa Cather in order to suggest

- that their works are examples of entertaining literature
- that their literary achievements were no less impressive than those of McMurtry
- that the themes of the Western genre could be employed in literature meant to appeal to a more sophisticated reader
- that they were contemporaries of McMurtry
- that the theme of westward expansion was a multicultural concept

Question 5

Consider each of the following answer choices separately and select all that apply.

According to the passage, the ideological undertones in McMurtry's novels stem from the

- introduction of strong female characters
- portrayal of the dangerous nature of the Western frontier
- subversive nature of the writing

It can be inferred that the author regards McMurtry's treatment of character with

- regret because McMurtry did not adhere to Western novelistic conventions
- concern that the characterizations altered the nature of the Western formula
- approval for the manner in which their inclusion transformed the Western genre
- puzzlement, because the characters seem insignificant to the plot
- enthusiasm, because the characters reform the conventionality of Western plots

“Hydrothermal vent” is the term that scientists use to describe a crack in a planet’s surface from which geothermally heated water emerges.

Line (5) Because these vents are common in places that are volcanically active, they are plentiful on Earth. While the most famous hydrothermal vent is probably the geyser at Yellowstone National Park in the United States, there are several different types of vents, existing both on land and

(10) underwater. Black Smokers, for instance, are a common type of submarine vent. The National Oceanic and Atmospheric Administration first discovered these in the vicinity of the Galapagos Islands in 1977. Underwater vents such as

(15) these form when water that has been heated by magma beneath the earth’s crust exits through cracks in the ocean floor. Scientists are interested in these vents primarily for their ability to host biologically dense communities in areas

(20) that are otherwise hostile to life. Studies show that Chemosynthetic archaea, a life form similar to bacteria, allows these areas to support such diverse organisms as clams and shrimp. Black Smokers are also visually striking. Minerals in

(25) the water that emerge from the earth’s crust crystallize around each vent to create their distinctive black chimney-like formations.

While on a vessel exploring the Atlantis Massif in the mid-Atlantic Ridge, scientists

(30) recently discovered a completely new kind of hydrothermal system, which they dubbed “Lost City.” Here, a “forest” of white limestone pillars rises 180 feet above the sea floor. There are several important differences that distinguish the

(35) hydrothermal vents in Lost City from the more familiar Black Smokers. The heat and fluid flow at Lost City is driven by the intermingling of seawater and mantle rocks on the sea floor, rather than by hot magma. As these fluids mix with

(40) magnesium-rich sea water, they deposit calcium carbonate and magnesium hydroxide, thereby creating the stunning white structures of Lost City. The fluids here are also much cooler (less

(45) than 100 degrees Celsius) and are composed of substances and gases that are different from those of Black Smokers. For instance, the fluids here have high pH content and contain significant amounts of hydrogen and methane gas.

The discovery of Lost City is still a fairly recent

(50) one, and scientists currently have more questions than answers. However, they hope that the insights they gain from this study will provide information that will lead to a better understanding of some of the earliest hydrothermal systems on earth and the life they supported.

(55)

Question 7

The primary purpose of the passage is to

- refute a well-established theory
- describe a newly discovered natural phenomenon and compare it to another
- explain how the study of a certain natural phenomenon has changed over time
- evaluate opposing theories

- reconsider a natural phenomenon in light of new discoveries

Question 8

Select the sentence that explains why Black Smokers have piqued the curiosity of biologists.

Question 9

Consider each of the following answer choices separately and select all that apply.

The passage suggests that the hydrothermal vents that constitute Lost City are different from Black Smokers in which of the following ways?

- Magma propels the heat and water of Black Smokers, whereas the vents at Lost City are driven by the merging of seawater and mantle rocks.
- Black Smoker vents release water that is much cooler than the water released at Lost City.
- Chemosynthetic archaea fosters many different life forms around Black Smokers but is not present at Lost City.

Question 10

Consider each of the following answer choices separately and select all that apply.

According to the passage, which of the following statements are true about Black Smokers?

- As water emerges from the vents it deposits calcium carbonate.
- Black chimney-like structures form around each vent.
- Black Smokers host biologically dense communities.

Questions 11-12 refer to the following passage.

The paintings of Eugene Delacroix are as political, complex, tumultuous, and vivid as the life of Lord Byron, who inspired some of Delacroix's best works, such as *Greece Expiring on the Ruins of Missolonghi* and *Scènes des massacres de Scio*. Simultaneously, the paintings boast an incredible mélange of the artistic traditions of prior masters and movements—such as a preoccupation with *terribilitas* from Michelangelo; (10) a flair for color from Titian; and power, strength, and exuberance from Rubens—all underlain by the harmony and balance of classical artists and tinted with the Baroque. Delacroix combined eclectic elements and infused them with his (15) own genius, creating a unique expression of Romanticism, and in so doing, inspired yet another style, Symbolism.

Question 11

Consider each of the following answer choices separately and select all that apply.

The passage suggests that which of the following are NOT unique elements of the paintings of Delacroix?

- A tint of the Baroque
- A preoccupation with *terribilitas*
- Diverse artistic traditions mixed with Delacroix's own acumen

Question 12

According to the passage, Delacroix's painting *Scènes des massacres de Scio* was influenced by

- Greece Expiring on the Ruins of Missolonghi
- a mix of artistic traditions
- the life of Lord Byron
- prior masters and their movements
- the Baroque period

Sociobiologists, the most well known of whom is Edward O. Wilson, contend that there is a biological basis for the social behavior of animals, and they test their hypotheses through observation of animals in situations. Species studied have varied as widely as to encompass both termites and rhesus macaques. Sociobiologists further argue that students of human behavior cannot adequately account for the panoply of human nature through only such traditional variables as culture, ethnicity, and environment but must also include evolutionary processes. However, many scientists, notably Stephen Jay Gould and Richard Lewontin, have criticized this approach to the study of humans on a number of grounds: for example, that it is based on Eurocentric notions and that it is plagued by methodological problems. These detractors label it a pseudo-science because sociobiological theories are not falsifiable and thus, in this respect, are similar to alchemy or astrology.

Question 13

Consider each of the following answer choices separately and select all that apply.

It can be inferred that Gould and Lewontin might agree with which of the following statements about a sociobiological approach to the study of humans?

- Sociobiological theories cannot be proven false, and consequently they cannot be conclusively verified; thus, sociobiology is not a real science.
- When applied to the study of humans, sociobiology is problematic because it is rooted in a Western worldview and it does not comport with proper scientific methodology.
- Scientists cannot adequately explain human behavior through the consideration of cultural, ethnic, and environmental factors alone; therefore, they must resort to sociobiological explanations.

Question 14

The author mentions culture, ethnicity, and environment in order to

- offer justification for a comparative study between termite colonies and rhesus macques
- assert that sociobiology is problematic because it is Eurocentric and beset by methodological complications
- illustrate that sociobiology is an inappropriate method for studying humans
- enumerate some variables that socio-biologists believe are insufficient in the study of humans and thus necessitate the addition of biological considerations
- provide a comprehensive list of the factors that influence human behavior

Question 15

The primary purpose of the passage is to

- offer praise for an influential scientific approach to the study of animal and human behavior
- argue for a sociobiological approach to the study of human behavior
- dispute a sociobiological approach to the study of human behavior
- justify a sociobiological approach to the study of termite colonies and rhesus macaques

○ set forth an influential approach to the study of animal and human behavior and discuss some objections to this approach

DRILL 3

Questions 1-2 refer to the following passage.

In *The Federalist Number Ten*, James Madison forewarned against the dangers of factions—groups of people with a common interest adverse to the overall good of the nation, what today are referred to as “special interest groups.” Madison described two hypothetical ways to check a faction: Either eliminate the causes or mitigate the effects of the faction. To eliminate the causes, the government would either have to make all people perfectly equal, an impossible goal, or take away people’s liberty and thus defeat the purpose of having a republican form of government. Madison argued, alternatively, for ameliorating the effects of factions by enlarging the population of the country and thus diluting their influence. If there are a sufficient number of diverse peoples, it will be difficult for a majority to share a common interest at the same time.

Question 1

According to the passage, why does Madison believe it necessary to check a faction?

- Madison considered factions to be detrimental to the common welfare.
- Madison thought factions were a way to encourage population growth.
- Madison relied on factions to support the republican style of government.
- Madison accepted factions as a consequence of allowing people to participate in government.
- Madison surmised that factions would likely be run by his political adversaries.

Question 2

Which of the following can be most correctly inferred from the passage?

- Madison solved the problem of factions in the United States.
- Madison thought that the best solution was to make all citizens equal.
- Madison argued against a republican government in *The Federalist Number Ten*.
- Madison analyzed the effects of increased population.
- Madison considered more than one way to constrain factions.

Questions 3-4 refer to the following passage.

William Le Baron Jenney is considered the founder of the Chicago School of architecture, as well as the father of the American skyscraper. He served as an engineering officer during the Civil War but by 1868 was a practicing architect. His greatest accomplishments were his mammoth commercial buildings, including the Home Insurance Building in Chicago, which was one of the first buildings to use a metal skeleton. This structure, in fact, would become the archetypical American skyscraper design. Other notable accomplishments included his 16-story Manhattan Building, which was the first edifice ever to achieve that height, and the Horticultural Building, which was the largest botanical conservatory ever erected.

William Holabird also assisted in the evolution of the Chicago School, beginning as a draftsman for Jenney and then founding his own practice in 1880. Holabird invented the "Chicago window," which made buildings appear to be constructed of glass.

Question 3

Consider each of the following answer choices separately and select all that apply.

According to the passage, which of the following describe William Jenney?

- He served as an architect during the Civil War.
- He is credited with the development of a much-copied design for skyscrapers.
- He designed buildings in New York, as well as Chicago.

Question 4

The author mentions the "Chicago window" in order to

- highlight a feature of glass buildings
- strengthen the argument that Holabird developed the Chicago School
- argue that Holabird was a better inventor than Jenney
- provide an example of Holabird's contributions to the Chicago School
- demonstrate the artistry of architecture

“Solar wind” is the term scientists use to describe the stream of particles that the sun’s corona constantly emits. These solar winds, which consist mainly of hydrogen and helium, are intensely hot, fully ionized plasma. Because of the corona’s intense heat, these particles continuously escape the sun’s gravitational attraction, flowing away from the sun at extreme velocities. Solar winds, though, are not without variation, because they contain faster and slower moving pockets. For instance, solar winds that originate from streamers are slower moving winds at approximately 300 km/second, as opposed to the winds that originate from corona holes and reach speeds of 800 km/second. As they flow away from the sun, tangential discontinuities and interplanetary shocks form, producing pressure variations. Moreover, researchers also know that solar winds are directly related to geomagnetic storms, auroras, and comets. It is these winds that cause comet tails to bend away from the sun, as Kepler accurately predicted in the early 1600s.

Studies have been done on the effect of solar winds on the planets in the solar system. While all the planets are surrounded by this hot, super-charged plasma, the Earth’s magnetic field protects it from the solar wind by deflecting the particles. However, solar winds are responsible for the Earth’s magnetosphere, and changes in their speed and direction strongly influence Earth’s space environment. As the planet closest to the sun, Mercury endures the main impact of solar winds. If Mercury had an atmosphere, these winds would have stripped it away, leaving the planet bathed in radiation. Though Mars is much further from the sun than Mercury, solar winds have also greatly reduced its atmosphere. While Venus has a substantial atmosphere—100 times denser than ours—solar winds reduce its clouds. It is not just those planets nearest the sun which bear the effects of solar winds: The winds travel far beyond the limits of Pluto. Interestingly, while much is now known about solar winds, scientists still do not fully understand how the gases and particles in the sun’s corona reach such high velocities.

Question 5

Consider each of the following answer choices separately and select all that apply.

According to the passage, which of the following is true of the effect of solar winds on the Earth?

- Though the Earth’s magnetic field largely protects it from the full effects of solar winds, the winds have an impact on its magnetosphere and its space environment.
- Solar winds play a significant role in the development of auroras and geomagnetic storms in the earth’s space environment.
- Because of the corona’s intense heat, solar wind particles continuously escape the sun’s gravitational attraction, flowing away from the corona at extremely high velocities and surrounding the Earth with hot, super-charged plasma.

Question 6

It can be inferred from the passage that the Earth’s magnetic field acts to

- absorb the particles blown by solar winds

- incorporate the particles present in solar winds

- assimilate the particles in solar winds into the Earth's atmosphere
- divert the particles in solar winds from the Earth
- re-orient the particles in solar winds toward a central collection point

Question 7

The author most likely discusses Kepler's predictions in order to

- illustrate the observable effect solar winds have had on other celestial objects
- denounce Kepler's work as unreliable because the technology required to study solar winds directly has only been developed within the last century
- describe more generally the first major contribution to the study of solar winds and the sun
- disprove Kepler's theories on the motion of comets and auroras
- establish a standard against which to compare the observations concerning the atmospheres of Mars and Mercury

Question 8

Select the sentence that attempts to correct a possible misconception about the effects of solar winds.

Questions 9-10 refer to the following passage.

The American people have an incorrect understanding of what it means to be at war. At least, so argues T.H. Pickett in his conservative interpretation of American military history.

Line

- (5) Pickett does present a wealth of examples, along with a refreshingly candid argument that America often goes to war for an abstract ideal such as democratization of societies, world peace, liberty, or freedom. For instance, the
- (10) Spanish-American War of 1898 was ostensibly a consequence of national enthusiasm for the cause of Cuban liberty. And, more obviously, America's entry into World War I stemmed from a desire to "make the world safe for democracy."
- (15) Although these observations are supportable, Pickett overstates the case when he argues that these abstract causes typically lead to a war hysteria in which American leadership can no longer enforce any measured policies.

Question 9

Consider each of the following answer choices separately and select all that apply.

It can be inferred from the description of Pickett's work that the author believes which of the following?

- The desire for tangible rewards is not always the primary reason that America enters into warfare.
- Democratization of a foreign country was a rationale for at least one war that America has waged.
- Pickett provides a large number of examples to bolster his case.

Question 10

Which of the following best states the author's main point?

- Pickett's study overturned the conventional understanding of why America engages in warfare.
- Pickett's study is valuable primarily because it provides a thorough understanding of the causes of American warfare.
- The rationale for American warfare is well documented.
- Pickett provides a cogent rationale for why America engages in warfare; however, he draws conclusions that the author does not fully support.
- Pickett's analysis of American military history provides the definitive historical record of the period from the Spanish-American War to World War I.

Questions 11-12 refer to the following passage.

Though artist Chuck Close has devoted his life to portraiture, his paintings rarely comport with that genre's traditional purpose. His early photorealist images, which are created by over-
Line (5) laying a grid on a photograph and painstakingly copying the image cell by cell, are, to the naked eye, nearly undifferentiable from photographs. Furthermore, Close's emphasis is on the disembodied head itself, expressionless and
 (10) devoid of any overt personality. He has never acceded to commissions, relying on both his own image and his friends as models. In 1988, a collapsed spinal artery caused almost total paralysis, but Close has continued to work. His
 (15) freer paintings evince a natural extension of an augmented interest in the minute grid over the total work that predated his illness. This non-privileging of any particular part of the canvas finds its inspiration, oddly enough, in abstract
 (20) expressionism, despite the apparent inconsonance of the two techniques.

Question 11

What is the author's intent when discussing Close's focus on the head of his subjects?

- The author compares the artistic impact of photographs of heads to that of abstract photographs of the same head.
- The author ruminates on what early experiences led to Close's focus on the head as a unifying theme in his work.
- The author expounds upon how, by not accepting commissions, Close's work has remained free of commercial influences.
- The author deconstructs the impact that Close's illness had on the content of his paintings.
- The author believes that Close's approach of depicting the head but none of the personality of the subject is rare.

Question 12

Consider each of the following answer choices separately and select all that apply.

Which of the following statements are supported by the passage?

- Close's portraits are so realistic that they are sometimes mistaken for photographs.
- There are conceptual connections between Close's later work and other, apparently dissimilar works.
- Throughout his career as an artist, none of the portraits Close has painted have been done in exchange for money.

The anti-foundationalist belief that there is no secure basis for knowledge was worked out philosophically in the somewhat wearisome tracts of Jacques Derrida. *Différance*, Derrida tells us, is the idea that any attempts to discuss universal features of human nature are merely products of local standards, often serving the vested interests of the status quo, and should rightly be dismantled and critiqued. Derrida was considered the originator of a profound challenge to the history of human thought. However, a century before Derrida, Darwin's theory of natural selection had made anti-foundationalism almost an inevitable consequence. From an evolutionary point of view, our understanding of the world depends on earlier and less-developed forms of understanding; meaning is continuously referred or deferred to other terms or experiences.

Question 13

Derrida's definition of difference suggests that he would most likely subscribe to which of the following beliefs?

- The interests of the status quo always maintain local standards.
- Ideas expressed by those who are part of the status quo do not necessarily represent a universally accepted truth.
- Any attempts to discuss human nature serve the interests of the status quo.
- The interests of the status quo should be critiqued and dismantled by those who are part of the status quo.
- Ideas that are a product of local standards cannot contain elements of a universal truth.

Question 14

Select the sentence which states a position with which the author does NOT agree.

Question 15

The passage implies that which of the following beliefs is embraced by anti-foundationalists?

- In many cases humans cannot be completely secure in thinking that they fully understand a given situation.
- The meaning of an experience can best be understood outside the cultural context in which it occurs.
- Those who are part of the status quo are best able to dismantle and critique society.
- Derrida's work would not have been possible without the prior ruminations of Darwin a century earlier.
- Darwin's faith in the status quo is sufficient grounds to develop universal truths about cultural experiences.

DRILL 4

Questions 1-2 refer to the following passage.

Some readers categorize Maxine Hong Kingston as a great Asian-American writer, a classification that is ultimately too narrow for her body of work. However, the subject matter of Kingston's novels and autobiographies espouses the Asian immigrant experience, as the following characters suggest: immigrant laborers in California and Hawaii, railroad laborers, and Chinese doctors. In natural harmony with her choice of subject matter are the personal sensibilities of a first-generation American writer who endeavors to explain her mother's alien sensibility and her relationship with her silent, angry father.

Kingston's Asian influences are present in another type of work, Chinese myths in the guise of "talk stories." A character in her novel *Tripmaster Monkey* is based on Sun Wu Kong, a mythical Chinese figure. In response to this work, Herbert Gold notes that the author "invigorates her novel with an avid personal perspective, doing what the novel is supposed to do—she brings us the news of the world and makes magic of it."

Question 1

Consider each of the following answer choices separately and select all that apply.

It can be inferred that Kingston uses "talk stories"

- to provide an outlet for critiques of her work
- as a way to present Chinese myths in her stories
- as a method of engaging children who are not yet reading on their own

Question 2

The author focuses on the content of Kingston's work primarily to

- illustrate why one might be tempted to call Kingston an Asian-American author
- assert why Kingston's work is difficult to categorize
- explain why Kingston's work is thought by many to have universal appeal
- illustrate how Kingston's work is affected by her parental influences
- show what makes Kingston unique among Asian-American writers

Préciosité, "preciousness," or the manifestation of the baroque in literature, is often dismissed as a "feminine concoction," mocked by Molière and thought to be ridiculous by modern standards. Preferring appearance to substance and excess to moderation, baroque expression is given to wild exaggeration and purple description. However, when one considers its historical context, the movement can be seen as a subtle rebellion by an otherwise powerless sex against its restrictive society.

Crippled and stunned from a series of religious wars, seventeenth-century France under Louis XIII was characterized by political intrigue and violence. Escaping the crude court, a group of cultured and educated ladies met to discuss—in a fantastically embellished and witty manner—literature, art, and philosophy. They rejected the predominant emphasis on vulgarity and sought the elevation of *l'éducation*, or "manners" they considered essential to society. More salons followed, and these *précieuses* (literally, "precious ones") produced works of literature that are still widely read, such as novels, essays, and poems that elevated the ideal of courtly, or Platonic, love with an emphasis on sensuality and scrupulous rules of behavior.

Though men scoffed at their wives' pretensions, baroque literature as a reaction to political instability reawakened French proclivities for cultural expression. When Louis XIV ascended to the throne in 1661, French society was primed for the reestablishment of the arts. Baroque ideals served important roles regarding the criticism of the political situation and the influence of cultural trends. Louis XIV's peace provoked the cultural pendulum to swing to the other direction, ushering in a neo-classical movement that elevated simplicity and minimalism. It is surely no coincidence that it was the performance of "Les Précieuses Ridicules" ("The Conceited Ladies"), Molière's play mocking *préciosité*, that first gained him wide acclaim and established him as the preeminent father of French theater.

Question 3

Consider each of the following answer choices separately and select all that apply.

The author suggests which of the following about how the *préciosité* was viewed during the seventeenth century?

- Literature can be a weapon of protest.
- Before the seventeenth century, the French expressed themselves through the arts.
- Literature was the only means of protest available to women in the seventeenth century.

Question 4

The primary purpose of the passage is to

- demonstrate the importance of the role of a specific artistic movement to a culture
- show that women had a greater influence on history than was previously thought
- define and explain the origins of an obscure art form

- emphasize the influence of a nation's ruler on its arts and culture

Question 5

Consider each of the following answer choices separately and select all that apply.

The author suggests which of the following about how préciosité was viewed during the seventeenth century?

- It became the preferred method of communication for all members of French society.
- It was tolerated until Molière's popular play mocked it.
- Its importance as a cultural force was not understood.

Question 6

Select the sentence that most concisely describes the contrast between préciosité and the neo-classicism that followed it.

Questions 7-8 refer to the following passage.

The mid-nineteenth century witnessed two major wars on U.S. soil: the Mexican-American War and the Civil War. That Abraham Lincoln would commit the country to civil war appears
Line (5) to require little explanation, since he endorsed the abolition of slavery and the preservation of the young nation. However, Lincoln's disdain for the Mexican-American War, which was ostensibly fought to keep Texas in the Union, requires
 (10) some examination. After all, Lincoln's swift military response to the Southern secessionists at the beginning of the Civil War illustrates that Lincoln would not shrink from battle if the war could ensure a united country. Perhaps Lincoln's
 (15) resistance to the Mexican-American War can best be seen in light of his sincere belief that President Polk had overstepped his constitutional boundaries in declaring war against Mexico, a sovereign nation. In this light, it is perhaps ironic
 (20) that Lincoln's own presidential legacy includes a greater centralization of federal government power.

Question 7

Consider each of the following answer choices separately and select all that apply.

According to the passage, which of the following is true of the Mexican-American War?

- Lincoln did not initiate the war.
- Lincoln would have disagreed with President Polk about its legality.
- It was fought ostensibly to abolish slavery.

Question 8

Which of the following best describes the function of the sentence about Lincoln's swift military response in the passage?

- It provides evidence that Lincoln generally did not oppose wars.
- It explains that Lincoln, despite his pacifist tendencies, was not convinced that the Mexican-American War effort was wrong.
- It confirms that Lincoln's belief in the wisdom of entering a war was formulated on the basis of what is good for a united country.
- It suggests that Lincoln's opinions on the Mexican-American War were not based solely on a belief in unification.
- It illustrates that opponents of United States foreign policy within the federal government convinced Lincoln to enter the Civil War.

Questions 9-11 refer to the following passage.

The increasing pressure on American businesses to pursue cost-cutting measures will eventually lead to an increase in the outsourcing of business processes to venues with lower overhead, such as India. However, this shift may not provide the dramatic gains for American business that might have been expected by an enterprise with an ethos for change that is oriented to preserving bottom-line profits. The difficulty is that a significant portion of American society remains uncomfortable with shifting business tasks overseas. Therefore, American businesses will predominantly opt for outsourcing opportunities for repetitive tasks that can easily be brought back to the United States if necessary. Nevertheless, opportunities for Indian firms to get a larger piece of the pie seem certain to arise. The growing emphasis on bringing down the cost of back-office operations is bound to offer increasing scope for Indian firms to become involved in novel types of ever more complex business processes.

Question 9

Select the sentence in which the author specifies a characteristic of jobs likely to be outsourced.

Question 10

The primary purpose of the passage is to

- present an overview of the different types of business opportunities available to Indian firms
- present a reasoned prognosis of the business opportunities that may become available to Indian firms
- present the trend toward outsourcing business operations as a model case of business operations in action
- analyze how opportunities available to Indian firms were necessitated by an increasing number of American firms
- analyze the use of cost-cutting measures as a substitute for outsourcing in the new American business climate

Question 11

Consider each of the following answer choices separately and select all that apply.

According the passage, despite the increasing pressure on American businesses to pursue cost-cutting measures, certain other factors preclude

- Indian firms' performing all of the business processes currently being performed onshore by American businesses.
- American businesses committing to outsourcing jobs overseas.
- Indian firms' outsourcing more complex tasks to American firms in order to create an interconnected hierarchy of business needs.

- Scientists are growing increasingly concerned that coral, which grows abundantly in the circumtropical shallow waters near bodies of land, is evincing a paling, or bleaching effect.
- (5) Though experts are still at odds over what has precipitated this event, most agree that it is a stress response to changes in habitat and water quality, including temperature variations and salination percentage, and predict a loss of
- (10) 95 percent of existing coral populations.
- An exemplary symbiotic entity, scleractinian coral lives harmoniously with vertebrates, invertebrates, and plants. Corals receive nutrients in two ways: by capturing planktonic organ-
- (15) isms with nematocyst-capped tentacles and by resource-sharing and recycling with single-celled algae called zooxanthellae. These algae live within the polyps of the coral, using photosynthesis to increase (and thereby strengthen) coral calci-
- (20) fication, and providing energy for coral growth. The zooxanthellae benefit from the relationship through protection from predators and a steady supply of necessary carbon dioxide. Interestingly, it is the zooxanthellae that provide coral with its
- (25) brilliant coloration.
- When coral loses its color, it is a sign that the single-celled algae are not able to thrive. Though not necessarily a sign of mortality, a pale, wan color indicates imminent danger and is con-
- (30) sidered a stress response. The zooxanthellate invertebrates lose their concentration of pigmentation or die altogether when stressed, turning translucent and allowing the slightly darker coral skeleton to show through the decaying tissue.
- (35) Whether this response stems from anthropogenic pollutions such as overharvesting coral for the exotic travel market, overfishing coral waters, and increased water temperatures due to global warming, or from natural disturbances (storms,
- (40) temperature extremes, and diseases), scientists fear for the future of the radiant corals. If zooxanthellate populations continue to decrease without recovery, their host corals will eventually follow suit, triggering a cascade of unanticipated
- (45) biological events.

Question 12

It can be inferred from the passage that zooxanthellae are

- able to use camouflage to blend into their surroundings
- dependent on carbon dioxide
- unable to live without coral hosts
- considered parasitical to coral
- unnecessary for the continued survival of coral

Question 13

The author attributes the pollution cited as being detrimental to coral to

- overpopulation by large sea mammals, such as dolphins
- activities of humans

- purely accidental causes which cannot be influenced
- overpopulation by photosynthetic archaeobacteria
- natural phenomena, such as changes in weather

Question 14

Select the sentence from the third paragraph that explains why zooxanthellae lose their coloration.

Question 15

It can be inferred from the passage that which of the following situations is a possible contributing factor to coral bleaching?

- The proliferation of large-scale freight ships in circumtropical regions
- Modern civilization's dependence on fossil fuels
- Tourists' demand for coral souvenirs
- Governmental apathy due to more pressing problems
- Coral's unusual sensitivity to the vagaries of natural climate changes

DRILL 5

Questions 1-2 refer to the following passage.

Country music scholars generally overlook the role that African-Americans played in the formation of this genre. Typically, scholars trace the birth of country music to the recording sessions that record producer and talent scout Ralph Peer held in Bristol, Tennessee, in 1927. However, the origins of country music go back much further and owe a great deal to African-American musicians, some known and some anonymous and unheralded. The banjo, field hollers, and gospel music are examples of country genre staples that are rooted in the African-American experience. Moreover, some of the “stars” of country music learned their trade from African-American musicians. Rufus “Tee Tot” Payne, for instance, educated Hank Williams. In addition to jazz, gospel, and the blues, country music now clearly needs to be included in the list of musical genres that have an African-American lineage.

Question 1

Consider each of the following answer choices separately and select all that apply.

It can be inferred from the passage that the author would be most likely to agree with which of the following statements concerning the contributions of African-Americans to country music?

- Rufus “Tee Tot” Payne is responsible for teaching Hank Williams the banjo, field holler, and gospel.
- African-Americans were instrumental in developing country music and for teaching it to some of the well-known musicians in the field.
- Jazz music is commonly acknowledged to have African-American lineage.

Question 2

According to the passage, the “African-American experience” (line 12) is crucial to country music because other previously established African-American genres

- other previously established African-American genres provided the instrumental and vocal basis for country music
- other previously established African-American genres were not as well developed as country music
- other previously established African-American genres preceded country music
- other previously established African-American genres weakened the popularity of country music
- other previously established African-American genres were more accepted and conventional than country music

Questions 3-4 refer to the following passage.

Face perception is the mind's ability to recognize and register another visage. It plays a significant role in social interactions. Through it we distinguish the familiar from the strange and formulate nuanced readings of people's moods and characters. However, controversy surrounds the process of face perception. Psychologists argue that it involves a series of stages: Individuals recognize physical features, make broad inferences regarding gender and age, and finally recall meaningful information regarding the face they perceive, such as a name. Cognitive neuroscientists, on the other hand, posit the idea that face perception works through analogy: The mind has an inherent ability to connect similar objects. While the exact process of face perception is still unclear, evidence suggests that it involves a specific set of skills and that the fusiform gyrus, a part of the brain, is necessary for it to occur.

Question 3

The author mentions cognitive neuroscientists in order to

- provide a specific example of a general idea the author mentions in the preceding sentence
- present one side in the debate surrounding the issue of how minds identify and understand faces
- trace the development of scientific inquiry into the phenomenon of face perception
- compare the process of face perception with the process of visual recognition more generally
- reconcile two contradictory view points

Question 4

What can be inferred from the use of the word "analogy" to describe face perception?

- Cognitive neuroscientists believe face perception works via a process of comparison.
- Psychologists believe face perception works via a process of dissemblance.
- Cognitive neuroscientists believe face perception works via a process of analysis.
- Psychologists believe face perception works via a process of resolving discrepancies.
- Cognitive neuroscientists believe it works via contraposition.

Line It has frequently been argued that freeing
 schools from the rigid rules, regulations, and
 statutes that have traditionally fettered them
 (5) would have a revolutionary effect on academic
 achievement. For instance, it has been sug-
 gested that schools embodying this idea could
 develop more effective teaching methods that
 could then be replicated in other schools. Char-
 (10) ter schools—public schools that operate under
 a contract, or “charter”—were given just such
 an opportunity beginning in 1991, when Minne-
 sota passed the first charter school law. At that
 time, many critics warned of deleterious rather
 (15) than beneficial effects that such freewheeling
 schools could have on the academic achieve-
 ment of students. Thus, while public opinion
 differed concerning the social desirability of
 charter schools, most agreed that there would
 be a pronounced effect.

(20) Surprisingly, educators who study educational
 reform now seriously question the degree to
 which charter schools have made an impact.
 They conclude that freedom from many of the
 (25) policies and regulations affecting traditional
 public schools and the concomitant control over
 decisions that guide the day-to-day affairs of
 the school have not resulted in equally dramatic
 changes in students’ academic performance. In
 (30) some states, charter schools are less likely to
 meet state performance standards than tradi-
 tional public schools. It is, however, impossible
 to know whether this difference is due to the
 performance of the schools, the prior achieve-
 ment of the students, or some other factor.

(35) Metrics for educational accountability have
 changed considerably in the past decade, mov-
 ing increasingly to performance as measured
 by state mandated tests of individual student
 achievement. Fundamentally, however, the chal-
 (40) lenging conditions under which schools operate,
 be they traditional or charter, have changed little:
 the struggle for resources, low pay for teachers,
 accountability to multiple stakeholders, and the
 difficulty of meeting the educational require-
 (45) ments of children with special needs all persist.

Question 5

Which of the following statements best summarizes the main point of the passage?

- Charter schools, despite their merits, fail to overcome the long-standing problems in public education.
- Recent studies have shown that charter schools have had a revolutionary effect on student achievement.
- Freeing schools from some of the restrictions that govern them has caused a change in education since 1991.
- Charter schools have created a whole new way of educating children that did not previously exist.
- Assessments of charter schools’ performance have reinforced the position that rigid rules and regulations are stifling academic achievement.

Question 6

Select the sentence from the second paragraph that best explains why author neither dismisses nor endorses the opinion of the critics of charter schools.

In the last paragraph the author mentions all of the following as challenges faced by all schools EXCEPT

- the difficulty of securing capital
- the challenge of providing appropriate conditions for special-needs students
- the necessity to answer to different interest groups
- the manner in which student performance is measured
- poor compensation for teachers

Question 8

Consider each of the following answer choices separately and select all that apply.

It can be inferred from the passage that the author would consider which of the following, if true, a likely indication of a fundamental alteration in education brought about by charter schools?

- Statistics show that the majority of children who attended charter schools in the 1990s are attending or have attended college.
- A national standard of academic performance, to which all students in every type of school must adhere, is created.
- A consistent score improvement in state-mandated tests has been achieved by children who attend charter schools, but not by those who attend traditional schools.

Many scholars consider Marcel Proust's *Remembrance of Things Past* (1913–1927) a significant literary achievement. For instance, Harold Bloom states that it is "widely recognized as the major novel of the twentieth century." In addition to noting its length—it spans seven volumes and 3,200 pages—many commentaries have focused on Proust's treatment of two kinds of memory, involuntary and voluntary. Involuntary memory occurs through the stimulation of the senses, while voluntary memory is a deliberate effort to remember the past. For Proust, involuntary memories are superior because they contain the spirit of the past in a way that voluntary memories do not; the former are more vivid, and they have the power to erase the temporal distance between the present moment and past experiences. More recently, scholars such as André Benhaïm have explored the relationship between Proust's treatment of memory and his representation of France and French culture. According to Benhaïm, memory functions within this text to reconfigure both.

Proust describes France in ways that one would not expect. In his work, French cities are archaic and exotic. As a result, the narrator becomes a stranger to, or is estranged from, his homeland, and lives the life of an exile. For instance, when recalling his travels through the fictional French town of Balbec, he states, "These strangely ordinary and disdainfully familiar cathedrals cruelly stunned my unconsidered eyes and stabbed my homesick heart." Words such as "stun" and "stab" suggest the hostility the narrator feels from this French territory. Proust's suggestion of Middle Eastern influences further distorts the idea of a singular French experience. First, the town's name refers to the ancient city of Baalbek, located in what is now Lebanon. Second, Balbec is populated by Jewish residents. Proust is widely recognized as an icon of French literature and culture, but ultimately his mysterious representations of this place and its culture call into question the existence of a single Francophone literature or a single French identity.

Question 9

Consider each of the following answer choices separately and select all that apply.

It can be inferred that Benhaïm might agree with which of the following statements about the role of memory in *Remembrance of Things Past*?

- The study of memory in Proust's novel is the most important approach to this text and has led to valuable insights regarding the human condition.
- The study of Proust's exploration of memory is a useful starting place with which to consider other issues, such as French culture and traditions.
- While the study of memory in Proust's novel once yielded interesting insights into the workings of the human mind, new approaches to this text have proven more useful.

Question 10

The author uses the quotation from *Remembrance of Things Past* in order to

- illustrate how Proust's concept of involuntary memory

- exemplify an assertion regarding the narrator's relationship to his homeland, which the author mentions in the preceding sentence
- mark a turning point in the passage in which the author switches from describing life in France to exploring Proust's representation of it
- bolster Proust's disdain for reliance on personal memories when returning to the locales of childhood
- dissuade the reader from accepting Proust's characterizations of voluntary memory

Question 11

Consider each of the following answer choices separately and select all that apply.

The passage refers to which of the following as a feature of the French town of Balbec, as Proust represents it?

- mausoleums
- itinerants
- churches

Question 12

Select the sentence from the second paragraph in which the author summarizes Proust's description of France.

According to scholars, the indigenous peoples of ancient Mesoamerica, specifically the Nahuas, developed a rich and complex philosophy comprising four interrelated and overlapping branches of knowledge: metaphysics, epistemology, theory of value, and aesthetics. At the core of their philosophy was *teotl*, which, rather than an immutable supernatural being like the Judaeo-Christian deity, was an ever-moving and ever-changing, self-producing sacred power that animated the universe and its contents. It was responsible for all things in nature—animals, rocks, rain, and so on—and permeated the details of everything. There was no distinction between *teotl* and the natural world; *teotl* was in every entity, and every entity was also *teotl*. Unlike Western philosophy, which fosters dichotomies such as the personal versus the impersonal, that of the Nahuas posited a sacred power that was united with everything; it was both intrinsic and transcendent.

Question 13

The definition of *teotl* and its comparison to the Judaeo-Christian deity plays which of the following roles within the passage?

- It compares a lesser-known idea to a more common one to further understanding.
- It contrasts the sacred power of *teotl* with a more familiar object of veneration in order to illustrate that cultures often possess diverging narratives on the origins of the world and the organisms therein.
- It provides an explanation of the origins of the cosmos according to some of the proponents of Western philosophy.
- It bolsters the case for accepting an aboriginal explanation for the creation of the universe over a Western one.
- It encourages further inquiry into a lesser known understanding of the world.

Question 14

Consider each of the choices separately and select all that apply.

In writing this passage, the author most likely intended to

- explain the system of principles that guided the customs of an ancient group of people
- elaborate on a theoretical belief that is incongruous with other beliefs on a similar topic
- describe the fundamental ideology of a certain society

Question 15

According to the passage, the ancient philosophy of the Nahua people is different from European-based philosophy in that

- at the center of Nahua philosophy was a detached and unmoving deity, whereas Christianity is based on the notion of a dynamic, ever-flowing supernatural force
- Nahua philosophy consisted of several interlocking concepts, whereas Western philosophy is composed only of dichotomies
- Nahua philosophy was based on the notion that a vivifying and mutable force saturated all matter, whereas in Western religion there is little or no division between supernatural powers and the natural world
- rather than promoting mutually exclusive but dependent binaries, Nahua philosophy fostered an integrated and holistic worldview
- within Nahuas society there was not a strong sense of individualism, whereas in Western societies, worldviews based on dichotomies engender excessive concern for self

DRILL 6

Questions 1-2 refer to the following passage.

The wombat is a muscular quadruped, about 3 feet in length with a short tail. The animal, which is not a mythical creature but an Australian marsupial, has a name derived from the language of the native peoples of the Sydney area, the Eora aboriginals. Wombats are herbivores and leave cubic scats that are easily recognized. Because wombats are seldom seen, attributed to the fact that they are nocturnal, the scats provide crucial evidence regarding territory. This large, burrowing mammal is not related to the badger, whose habits are similar. In fact, the koala is the wombat's closest relative. The principal burrowing instrument of the latter is its incisors which, like those of other rodents with orange enamel, are never worn down. Burrows can be extensive and shared by more than one wombat, despite the generally solitary nature of the creature. Territories within the burrow are marked by scent, vocalizations, and aggressive displays.

Question 1

Consider each of the choices separately and select all that apply.

According to the passage, which of the following is NOT true regarding wombats and their territory?

- Scats are the only way to determine territorial limits of wombats.
- The question of how much territory a wombat covers is of interest to some people.
- Wombats are generally not territorial about the space they occupy within their burrows.

Question 2

The author states that the wombat is an Australian marsupial in order to

- describe the role of stories about the wombat as part of the Eora's oral tradition
- dispel the belief of some people that the wombat is not a real animal
- create parallels between the Eora culture and the mythology of the ancient Greeks
- contrast the behavior of wombats with that of other rodents
- undermine the validity of research surrounding naming standards

Theorists are divided about the cause of the Permian mass extinctions. Some hypothesize that the impact of a massive asteroid caused a sudden disappearance of species. However, a
Line (5) look at the carbon-isotope record suggests that existing plant communities were struck down and re-formed several times. To produce such a pattern would require a succession of asteroid strikes thousands of years apart. Other theo-
(10) rists have proposed that volcanic explosions raised the CO₂ levels, leading to intense global warming. One problem with this theory is that it cannot explain the massive marine extinctions at the end of the Permian period. A new theory
(15) posits that rising concentrations of toxic hydrogen sulfide in the world's oceans plus gradual oxygen depletions in the surface waters caused the extinctions. Fortunately, this theory is test-
able. If true, oceanic sediments from the
(20) Permian period would yield chemical evidence of a rise in hydrogen sulfide-consuming bacteria.

Question 3

The primary purpose of the passage is to

- present several hypotheses concerning the cause of the Permian mass extinctions
- discuss the strengths and weaknesses of the asteroid hypothesis of the Permian mass extinctions
- propose that theories regarding the cause of the Permian mass extinctions be tested
- argue that Permian mass extinctions could not have been caused by a volcanic explosion
- describe one reason that a rise in hydrogen sulfide would cause massive marine extinctions

Question 4

Which of the following, if true, would most weaken the author's conclusion about the hydrogen sulfide theory?

- The oceanic sediment is geologically inactive.
- Changes in the chemical composition of oceanic sediment have rendered the Permian period indistinguishable from earlier periods.
- The oceanic sediments of the Permian period contain unusually high levels of carbon.
- The oceanic sediments contain many chemicals more toxic than simple hydrogen sulfide.
- The oceanic sediments can mask large populations of other types of bacteria.

In her self-portraits, Frida Kahlo blends realism and fantasy to capture the psychological and physical pain she constantly endured as a result of the trolley car accident she experienced as a young woman. This self-representation sets her apart from her contemporaries, who were more interested in public forms of art, such as murals. This was the time of the Mexican revolution, after all, a period that fostered an interest in nationalistic themes.

The more well-known artists of this period included David Alfaro Siqueiros, Diego Rivera, Jose Clemente Orozco, and Juan O’Gorman. These figures dominated the Mexican art world in the 1920s and 1930s. Unlike her contemporaries, Kahlo’s work did not achieve recognition until long after her death. In the late twentieth century, she became a feminist icon, a phenomenon attributable to the candor with which she portrayed issues relating to women.

Question 5

The purpose of the author’s discussion of the Mexican revolution is to

- provide a historical context for the reader to clarify what distinguished Kahlo’s art from her contemporaries’ art
- discuss aspects of Mexican history, such as the revolution and nationalism, which were irrelevant to Kahlo’s art
- contrast the way male and female artists responded to a tumultuous time in Mexican history
- explain why it was not until after Kahlo’s death that her work received greater acknowledgment
- highlight the differences between feminists and revolutionaries at the time that Kahlo was painting

Question 6

Consider each of the following answer choices separately and select all that apply.

Which of the following can be inferred from the passage about Kahlo’s contemporaries:

- They never painted self-portraits.
- They received recognition for their work while they were still alive.
- They used their art as a form of political expression.

The controversial concept of terraforming, or changing a planet's atmosphere to make it more habitable for humans, is still no more than a theoretical debate. However, the most recent data from two American Mars Rovers suggest that the terraforming of Mars may be more feasible than previously thought. The rovers found evidence of stratification patterns and cross bedding (indicating a history of sediment deposited by water) in rocks on the edges of craters, as well as chlorine and bromine, suggestive of a large body of salt water. If Mars once held water, it is possible that its atmosphere was at one time somewhat similar to Earth's. Even if this theory were true, however, scientists would have to prevent a recurrence of the desiccation of the Martian atmosphere once it is made habitable, as well as endeavor to preserve any extant life. Of course, until a reliable method of transporting humans to Mars is developed, any possibility of terraforming is mere conjecture.

Question 7

Consider each of the choices separately and select all that apply.

It can be inferred from the passage that the author would be most likely to agree with which of the following statements?

- Whether conditions on Mars are conducive to human habitation is not the only issue that limits realistic consideration of terraforming.
- If we terraform Mars, it will be important to think about the long-term effects of changing a planet's climate.
- It is highly likely, according to recent data, that there is, or was at one time, life on Mars.

Question 8

Which of the following statements, if true, would most likely make terraforming Mars more feasible?

- Scientists have devised a technique to provide a layer of carbon dioxide in the Martian atmosphere, which would trap solar radiation and thus modify temperature.
- Mars has stronger solar winds than does Earth, thus, making it difficult to retain atmospheric gases.
- Mars' core has cooled faster than Earth's, and its temperature is much lower than Earth's.
- Terraforming Mars is likely to have a galvanizing effect on Earth's governments.
- Terraforming Mars is unlikely to disturb life on other planets, should it exist.

The harshness and extreme unpopularity of the "war communism" system imposed in Russia from 1918 to 1921 led the Soviet leadership to adopt the New Economic Policy (NEP) in March of 1921. Under the NEP, the prodnalog system of tax in kind was begun, and a semi-market economy was allowed to develop alongside government control of what Lenin had called the "commanding heights industries." When the NEP was abandoned in 1927, the state declared it a failure as a result of several adverse events: the scissors crisis, the goods famine, and speculation by "NEPmen."

The scissors crisis of 1923 was caused by high industrial prices relative to agricultural prices. When these two sets of prices are graphed, the wide disparity resembles an open pair of scissors. The government had been spurring industry but felt that this price disparity had to be immediately addressed. To do so, it adopted policies favoring agriculture. There is some speculation by economists, however, that the scissors would have closed on their own.

The goods famine occurred at roughly the same time. Because of burgeoning industry, demand for industrial and consumer products skyrocketed. The state could not produce goods equal to demand, forcing prices up. In the midst of shortages, the state found itself in a losing contest with "NEPmen," small entrepreneurs who sold goods at prices often higher than those of the state. NEPmen were seen as capitalists who sought to return the Soviet state to its position as lapdog to the Western capitalist states. Since the state could not produce or profit as well as the NEPmen, it adopted measures to put the NEPmen out of business. By 1926, speculating on pricing was a crime. As a result, profits and incentives had fallen, and the speculation crisis was somewhat alleviated.

Question 9

Select the sentence from the third paragraph which describes an action undertaken by the Soviet government.

Question 10

The speculation by economists refers to which of the following beliefs?

- The government's belief that the crisis would one day have ended, even if the government had not moved to support agriculture
- Economists' belief that the government was mistaken in supporting agriculture over industry
- Economists' belief that the scissors crisis could have been averted without government intervention
- Economists' belief that the price disparity would have eventually resolved itself without action by the government
- The government's belief that agricultural and industrial prices would have balanced each other, but not in time to stop a crisis from occurring

Question 11

Which of the following would make the most appropriate title for this passage?

- The Fall of the New Economic Policy

- An End to War Communism

- Why the New Economic Policy Failed
- Three Crises that Ended an Era
- Soviet Economic Systems: an Overview

Question 12

Consider each of the choices separately and select all that apply.

It can be inferred from the passage that each of the following accurately represent the author's opinions EXCEPT

- NEPmen were like capitalists, who sought to earn their fortune at the expense of others and brought about the downfall of the NEP.
- The government was partially responsible for the goods famine, due to its inability to control supply and demand.
- The war communism system caused the scissors crisis by spurring agriculture prices.

The determination of the age of KNM-ER 1470, a humanoid skull, would add greatly to our knowledge of mammalian evolution. Anthropologists originally dated the *habilis* skull at 3 million years old. This age seemed unlikely because it was older than the age of any known australopithecines, which are presumed to be the *habilis*'s ancestor. Further attempts to date the skull have led to speculative results.

(10) An elemental property of all living things is that they contain a certain portion of their carbon as the radioactive isotope carbon-14. Carbon-14 is created when solar radiation blasts nuclei in the upper atmosphere, in turn producing neutrons that bombard nitrogen-14 at lower altitudes, turning it into carbon-14. All living things maintain an equilibrium of carbon-14 as they exchange carbon with their surrounding atmosphere. Presuming the rate of production to be constant, the activity of a sample can be compared to the equilibrium activity of living matter, and thus the age can be calculated. However, carbon-14 decays at a half-life of 5730 years, limiting age determinations to the order of 50,000 years. This time frame can be extended to perhaps 100,000 years using accelerator techniques. Even so, at these ages carbon dating is increasingly unreliable as a result of changes in the carbon-isotope mix. Over the last century, the burning of fossil fuels, which have no carbon-14 content, have had a diluting effect on the atmospheric carbon-14. As a countervailing effect, atmospheric testing of nuclear weapons in the 1950s may well have doubled the atmosphere's carbon-14 content.

(40) Other radiometric dating methods, using relative concentrations of parent-daughter products in radio decay changes of other elements, such as argon, may prove to be of greater benefit for dating such ancient samples as *habilis*. However, the assumption that the decay rates of these isotopes have always been constant would first have to be substantiated.

Question 13

Consider each of the following answer choices separately and select all that apply.

The author suggests that the burning of fossil fuels has had which of the following effects on the efficacy of carbon dating techniques?

- It may increase the carbon-isotope mix of the object being dated.
- It may make items subjected to carbon dating appear to have died later than is the case.
- It may tilt the fragile equilibrium activity of living matter.

Question 14

The author first mentions the half-life of carbon in order to

- provide a reason why carbon dating techniques fail to give an age for the *habilis* skull
- explain the success of carbon dating techniques
- illustrate the difference between carbon dating and other techniques
- show the need for extending carbon dating results with accelerator techniques

- illustrate the carbon equilibrium that all living things maintain

Question 15

What can be inferred about the proposed solution mentioned in the final paragraph?

- Continued experimentation with nuclear weapons could restore the expected carbon-14 content to the atmosphere to ensure accuracy of carbon dating.
- Alternatives to fossil fuels should be pursued to prevent further interference with carbon dating procedures.
- Decay rates of isotopes involved in radiometric methods need to be invariable.
- Carbon-14 levels could be artificially restored to previous historical levels to allow an appropriate basis of comparison.
- Appropriate technology to implement radiometric methods needs to be engineered.

Question 16

Select the sentence in the passage in which the author raises a possible objection to proposed alternatives to carbon dating.

ANSWERS

Drill 1

1. C
2. A, B
3. B
4. B, C
5. B
6. E
7. A
8. This experiment suggests that, should a potential donor organ be infused with these trigger molecules before the organ is harvested, the organ would remain transplantable for up to 45 hours, greatly increasing the chance for doctors to find a suitable recipient.
9. B
10. C
11. A, C
12. Thus, she is a progenitor of Chopin...
13. B
14. C
15. B

Drill 2

1. C
2. A
3. In his novels, McMurtry creates strong female characters, transmuting...
4. C
5. A, C
6. C
7. B
8. E
9. A
10. B, C
11. A, B
12. C
13. A, B
14. D
15. E

Drill 3

1. A
2. E
3. B
4. D
5. A, B
6. D
7. A
8. It is not just those planets nearest the sun...
9. A, B, C
10. D
11. E
12. C
13. B
14. Derrida was considered the originator of a profound challenge...
15. A

Drill 4

1. B
2. A
3. A, B
4. A
5. C
6. Preferring appearance to substance and excess to moderation...
7. A, B
8. D
9. Therefore, American businesses will predominantly opt for outsourcing.
10. B
11. A, B
12. B
13. B
14. The zooxanthellate invertebrates lose their concentration of pigmentation or die altogether when stressed, turning translucent and allowing the slightly darker coral skeleton to show through the decaying tissue.
15. C

Drill 5

1. B, C
2. A
3. B
4. A
5. A
6. It is, however, impossible to know whether this difference is due to...
7. D
8. C
9. B
10. B
11. C
12. In his work, French cities are archaic and exotic.
13. A
14. B, C
15. D

Drill 6

1. A, C
2. B
3. A
4. B
5. A
6. B, C
7. A, B
8. A
9. By 1926, speculating on pricing was a crime.
10. D
11. C
12. A, C
13. B
14. A
15. C
16. However, the assumption that the decay...

Drill 1

1. C The passage describes the mesosphere as elusive, poorly understood and little explored. The answer closest to this is choice (C), unfamiliar. Although the passage states that waves travel through it, it never says it is turbulent: The waves could be small or large. Choices (A), (B), (D), and (E) are never mentioned in the passage.

2. A, and B

This question asks about things which could affect the mesosphere. According the passage, the mesosphere is affected by tides and waves that propagate up from the troposphere and stratosphere, so choice (B) is correct. The mesosphere is also further affected when gas particles in the mesosphere collide with meteoroids, so choice (A) is also correct. Although the passage mentions tides, it does not specify that they are oceanic tides, so choice (C) is incorrect, and the answers are choices (A) and (B).

3. B The author says the Nielsen Company has questionable methods and has come under criticism, and puts the word diaries in quotes as though to make fun of its methodology as quaint or clunky, so choice (B) is the best answer. There is no indication that Nielsen's bias is intentional, so eliminate choice (A). Choices (C) and (D) are extreme because the passage does not suggest that Nielsen's research is so bad as to be worthless or unscrupulous. The passage does not offer any information about Nielsen's opinion of itself, boastful or otherwise, so eliminate choice (E).

4. B and C

The passage says that the percentage indicates the number of viewers watching, so choice (A) is not correct. The passage says that residences underreport daytime and late-night television viewing, so choice (B) is true. Finally, the passage says that gauging how attentive the audience is to ... advertising is a nonviable practice. Because the first paragraph says that advertising rates are determined by the viewership, choice (C) is true. Attentiveness would be another relevant factor.

5. B The woodchuck example is provided to show that the same molecules that induce hibernation might have applications in organs being readied for transplants. Therefore, choice (B) is the best answer. There is no evidence that ischemia plays any role in the transplantation process, so choice (A) is incorrect. Choice (C) is too extreme; nothing is identified as the biggest obstacle. The passage does not comment on the feasibility of changing the tissue-matching process, so choice (D) is not a well-supported answer choice. The passage does not mention the effects of HIT on patients awaiting transplants, so choice (E) is wrong.

6. E The passage describes an experiment wherein infusing opioids delayed decay, so choice (E) is true. Choice (B) is incorrect because the passage does not state that the lymphatic system is what causes organs to deteriorate. There is no information in the passage on when HIT will be produced in a lab, so choice (C) can be eliminated. Choice (D) extrapolates too far on the effects of HIT, and there is not enough information in the passage to support the relationship in choice (A).

7. A Choice (A) is the best answer because the author cites the experiment with woodchucks to give an example of a promising line of research. There is no suggestion of genetic similarity, so choice (B) is incorrect. Though the author does warn that the findings are preliminary, he/she does so in another context in the passage, which makes choice (C) wrong. Similarly, other areas of science are not mentioned in conjunction with this experiment, but rather later on in the passage, so choice (D) is incorrect. Though an interspecies infusion of HIT is mentioned, that is not the primary purpose of the woodchuck experiment, and choice (E) is incorrect as well.

8. This experiment suggests that, should a potential donor organ be infused with these trigger molecules before the organ is harvested, the organ would remain transplantable for up to 45 hours, greatly increasing the chance for doctors to find a suitable recipient.

The correct sentence indicates that the molecules must be infused before the organ is harvested; this is a limitation. If you chose the sentence in the last paragraph that includes the phrase patients are still susceptible to infection and rejection, you should realize that infection and rejection are not problems related to infusing HIT molecules, but rather of the transplant process itself. Also, the sentence after that one, which begins scientists are still a long way... mentions the limitation of safety and consistency, problems which the question specifically indicates are not what you should be looking for in the correct answer.

9. B The text is primarily concerned with showing the ancient origin of modern currency and underlines the touchstone's importance within this history; therefore, choice (B) is correct. Choice (A) is too broad—the passage is concerned only with currency, not science in general. Conversely, choice (C) is too narrow; the passage talks about the touchstone's historical importance, not just the science behind it. The passage does not discuss where the word came from, so choice (D) is incorrect. Choice (E) is also wrong because there is no historical misconception that needs to be cleared up.

10. C Choice (C) accurately describes the reason for including the details concerning the inclusion of lesser metals in early coins: It takes the details of how the touchstone works and shows why the touchstone was important for trade. The passage does not state how individuals previously tested metals, so choice (A) cannot be true. Choice (B) is also incorrect because the date given in the passage is of the earliest use of coins; it does not talk about the date of the touchstone. The purpose of the sentence is not to give a cultural context because the passage does not identify the cultures involved, so eliminate choice (D). There is no counterargument given, making choice (E) incorrect.

11. A and C

Choices (A) and (C) are supported by the phrases this probing process allowed merchants to examine alloys quickly and with reasonable certainty. You know that the certainty referred to is about adulterated coins because the passage later mentions that coins

were easily forged or diluted. Choice (B) is incorrect because although the passage does mention standardization, it does not mention specifically that it would be a function of the government.

12. Thus, she is a progenitor of Chopin... A progenitor is a precursor or an ancestor, so the correct sentence tells you that Szymanowska's techniques and compositions came before and influenced those of Chopin. The other composers mentioned in the passage are either described as her contemporaries or given no chronological relationship to Szymanowska, so none of the other sentences that refer to composers can be supported.
13. B The author states human society will be poorer for its inability to recognize the expertise and inventiveness of these women. The author states this as a blunt fact: Choice (B), emphatic, is closest to this, as the author states, with emphasis, his opinion. The author does not wish for the past to return, so choice (A), nostalgic, is incorrect. The author is not dismissive of the musicians, but rather dislikes the fact that others have dismissed the musicians, so choice (C) is incorrect. The final sentence is unequivocal, so choice (D), equivocal, is incorrect. The author is not being instructive, so didactic is incorrect, and the answer is choice (B).
14. C Choice (A) describes a problem, but it is too extreme because some documentation must exist for people to know about Szymanowska's work. Choice (B) also describes a problem but is too specific—musical scores were never mentioned. Choice (C) provides a good paraphrase of the second and third sentences of the last paragraph and is, therefore, the best choice. Choice (D) is too extreme. If you chose choice (E), you probably were looking at the last line of the passage, which talks about the future, not about the past and present.
15. B Choice (A) is not supported: Although the passage does say that women's role in the development of Polish music was largely ignored, there's no indication that Szymanowska composed music to make a statement about feminism. Choice (B) is supported: All her pieces have technically superior elements, but only two are specified to have Polonaise rhythms. Choice (C) is not supported: The passage never specifies which of her over one hundred works were most highly praised, and more specific information is needed before a judgment of disproportionate amount of attention can be justified.

1. C The first sentence states that sociologists have historically held the view that individuals stereotype. The rest of the paragraph delves into Hepburn and Locksley's study, which investigates the extent to which people are aware of their own stereotyping behavior. Therefore, the first sentence provides the historical background for Hepburn and Locksley's study. The closest answer is therefore choice (C).
2. A The passage starts with a historical overview of stereotypes and then focuses on two investigators who look at the related issue of whether or not individuals are aware that they are applying stereotypes. Choice (A) sums this up the best. Choice (B) is out of scope. Choices (C) and (D) are too strong; it is neither an attempt to prove nor to refute anything. Choice (E) is too specific, and the passage doesn't contain any detailed lists.
3. In his novels, McMurtry creates strong female characters, transmuting... The third paragraph discusses the differences between the traditional Western formula and McMurtry in their treatment of character. The main difference this paragraph focuses on is that the traditional Westerns feature mostly male characters, whereas McMurtry focuses on female characters. The identified sentence says that McMurtry's creation of strong female characters folds in deeper ideological insights. This is a good thing, suggesting that the author views this practice with a positive eye. The final sentence may be tempting, but it conveys the opinion of critics, not necessarily the author, and it doesn't specifically address the issue of gender.
4. C In the first paragraph the author notes how Western literature ranges from lowbrow entertainment to great literature and offers the dime-store novel as an example of writing that is merely entertaining. At the other end of the spectrum, the author states that James Fenimore Cooper and Willa Cather, however, used themes of westward expansion in works clearly intended as highbrow literature. In other words, they wrote literature that expects the reader to be more sophisticated, so the best answer is choice (C). Choice (A) is incorrect, choices (B) and (D) are not discussed in the passage, and choice (E) is off the topic.

5. A and C

McMurtry folds in deeper ideological insights by using strong female characters, so the female characters referenced in choice (A) definitely contribute to the ideological undertones. Subversive means rebellious or going against the norm; in this case, McMurtry's writing goes against the ideology of the traditional Western. The subversive differences in McMurtry's writing referenced throughout the passage are thus indicative of his ideology. The focus on the dangerous nature of the Western frontier is a characteristic of the traditional Western, not McMurtry's Westerns, so choice (B) is not an indication of the ideology of McMurtry's novels.

6. C In the last paragraph the author talks about McMurtry's use of character, stating that In his novels McMurtry creates strong female characters, transmuting the conventional plot of the trials and dangers of the frontier by folding in deeper ideological insights. When referring to the critics, the author notes that they rightly credit his novels with reforming the Western genre. The use of the word rightly suggests that the author agrees with the critics, thereby making choice (C) the best answer.
7. B Choice (A) isn't supported in the text. Eliminate choice (C) because, while the passage suggests that the body of knowledge relating to hydrothermal vents is expanding due to a recent discovery, the author doesn't really look at how scientists study hydrothermal vents or mention how these studies might have changed. Choice (D) isn't supported in the passage. In choice (E), while the author discusses the discovery of a new natural phenomenon, the author doesn't reconsider or reevaluate previous studies on similar natural phenomenon. Choice (B) is the correct answer and is an accurate summary of the author's purpose over the course of the passage.
8. E Scientists are interested in these vents primarily for their ability to host biologically dense communities in areas that are otherwise hostile to life.

To hone in on the correct sentence, use lead words to find the general part of the passage which likely holds the answer to the question. In this case, the words Black Smokers leads you to the first paragraph. The question asks you why the biologists' curiosity is piqued, so the sentence you are looking for is explanatory and refers to the value of the Black Smokers. The sentence beginning with Scientists are interested... is an answer to a why question, and you can make the link between biologists in the question and biologically in the sentence.

9. A The passage states that the heat and fluid flow at the Lost City is driven by the intermingling of seawater and mantle rocks on the sea floor, rather than by hot magma. This statement means that the vents at Lost City are driven by the merging of seawater and mantle rocks. The rather than indicates a comparison between Lost City and some other hydrothermal vents. The only other vents mentioned in this paragraph are the Black Smokers, so they must be driven by hot magma. Choice (B) is directly contradicted by the passage, which states that the fluids here are much cooler, referring to Lost City. Chemosynthetic archaea are mentioned only in paragraph one, and thus choice (C) is out of scope for a question about paragraph three.

10. B and C

Choice (A) is a true statement from paragraph two, but it is a statement about the Lost City, while the question asks about the Black Smokers. Black chimney-like formations are mentioned in the last sentence of paragraph one, which discusses the Black Smokers, so you know that choice (B) is a true statement about the Black Smokers. Paragraph one also states that scientists are interested in these vents primarily for their ability to host biologically dense communities in areas that are otherwise hostile to life. Since the rest of this paragraph is talking about the Black Smokers, this statement must mean that Black Smokers do host biologically dense communities, supporting choice (C).

11. A and B

Because this is a NOT question, you are looking to eliminate answer choices that are unique elements of Delacroix's work in the

passage. You will find the statement: Delacroix combined eclectic elements and infused them with his own genius, creating a unique expression of Romanticism. Therefore eclectic elements and own genius are the ingredients in his unique expression. Eliminate choice (C), which paraphrases and reiterates this thought; you need a choice describing what is NOT unique. Choices (A) and (B) are also supported in the passage as elements that Delacroix borrowed from an entire period, in the case of choice (A), or from another artist, in the case of choice (B). Because he borrowed those elements, they are not unique and are correct answers.

12. C The painting in the question is mentioned in the first sentence of the passage: The paintings of Eugene Delacroix are as political, complex, tumultuous, and vivid as the life of Lord Byron, who inspired some of Delacroix's best works, such *Greece Expiring on the Ruins of Missolonghi* and *Scènes des massacres de Scio*. Therefore, Lord Byron inspired the painting in question, so choice (C) is correct. Choice (A) is a painting that was also inspired by Byron but is not the inspiration for the painting in the question. Choices (B), (D), and (E) are all mentioned elsewhere in the passage, but do not answer the question asked.
13. A and B
Gould and Lewontin believe that sociobiology is flawed because it is Eurocentric and has methodological problems. Western worldview is another way of saying Eurocentric; coupled with not comport with proper scientific methodology, choice (B) is a paraphrase of Gould and Lewontin's position. These detractors (i.e., Gould and Lewontin) call sociobiology a pseudo-science, meaning a fake science, because it is not falsifiable, meaning that it cannot be proven false. This position is consistent with choice (A).
14. D The author discusses culture, ethnicity, and environment in relation to the justification offered by sociobiologists when applying sociobiology to humans: In their view, these factors don't adequately explain human behavior. Choice (D) is a good paraphrase of this justification. Choice (A) isn't supported in the passage. Choice (B) is Gould's and Lewontin's position on sociobiology. Choice (C) contradicts the sociobiologists' view. Choice (E) is incorrect because, although the list comprises some factors that influence human behavior, the author intends it to serve a greater purpose in the passage. In addition, it would be extreme to assert that the list is comprehensive.
15. E The author doesn't praise either side in the debate, so eliminate choice (A). Both choices (B) and (C) suggest that the author has a point of view, while the passage offers no indication as to which side the author may favor. Eliminate choice (D) because no such justification is made, and the thrust of the passage is on human, not animal, behavior. Choice (E) is an accurate summary of the entire passage because it takes into account both sociobiological theories and their critics in an impartial fashion.

1. A The reason for controlling factions is described in the opening sentence with Madison's claim that they are adverse to the overall good of the nation. Choice (A) is the best answer. Choices (B), (C), and (D) are not accurate based on the information in the passage. Since Madison never specifies exactly who will make up the factions, choice (E) is correct.
2. E The passage discusses Madison's theories on constraining factions by controlling either their causes or effects. Choice (A) goes too far; the passage does not solve the problem. Choices (B) and (C) are contrary to the passage. Choice (D) is overly broad; the passage considers only one effect of increased population. Choice (E) is the best answer because it encompasses the scope of Madison's ideas in The Federalist Number Ten.
3. B One of Jenney's designs would become the archetypical American skyscraper design. An archetype is an original model from which many copies are made, lending support to choice (B). Jenney served as an engineering officer during the Civil War, not an architect, so choice (A) is incorrect. One of Jenney's buildings was called the Manhattan Building, but that does not necessarily mean that it was located in New York (in fact, the building is in Chicago), so choice (C) also lacks support.
4. D Choice (D) is the best answer. The Chicago window is a development of Holabird's; it is the only specific feature mentioned, so it must be significant. Choice (A) is partially correct, in that a feature is highlighted, but the buildings are not made of glass; they merely appear to be glass. Choice (B) says Holabird developed the Chicago School, but the passage says he helped Jenney do so. Choice (C) goes against the tone of the passage, which does not make that argument at all. Choice (E) is too broad to be the purpose of this small detail.
5. A and B
 Since solar winds are directly related to geomagnetic storms, auroras, and comets, and cause comet tails to bend in particular directions, they play a significant role in the development of auroras and geomagnetic storms, thus supporting choice (B). The second paragraph states both that the Earth's magnetic field protects it from the solar winds, and that solar winds are responsible for the Earth's magnetosphere, and changes in their speed and direction strongly influence Earth's space environment, thus supporting choice (A). The first part of choice (C) is almost an exact reproduction of sentence 3, but that sentence doesn't say anything about super-charged plasma.
6. D The author uses the word deflecting to describe the action of Earth's magnetic field in the face of the solar winds. In other words, the earth's magnetic field protects the earth by turning aside the harmful, radiation-filled solar winds. Look for an answer choice that has a similar meaning. Eliminate choices (B) and (E) because they are not supported by the text. Eliminate choices (A) and (C), which contradict the passage. Choice (D) is the correct answer because the word divert is a synonym for the word deflect, and this action would provide the protection that is observed.
7. A Eliminate choice (B) because it is not supported by the text; the author makes no mention of the technology required for scientists to observe solar winds. Eliminate choice (C) for similar reasons; while Kepler made an accurate guess regarding comet tails and the reasons for which they bend away from the sun, one cannot infer that these observations constitute the first major contribution to the study of solar winds or the sun more generally. Choice (D) goes beyond the scope of the text in discussing Kepler's work, and choice (E) compares two different types of information. The correct answer is choice (A).
8. It is not just those planets nearest the sun... The credited response, the second sentence from the end of the passage, indicates that some people might be expected to believe solar winds only affect the innermost planets. If you were tempted by the sentence that begins Solar winds, though, are not without variation, be sure to read the question carefully: Like most of the first paragraph, that sentence focuses on the solar winds themselves, rather than their effects.
9. A, B, and C
 Choice (A) is supported by the characterization of the argument that America often goes to war for an abstract ideal as refreshingly candid. Choice (B) is supported by the inclusion of democratization of societies in the list of such ideals, as well as by the examples of the Spanish-American War and World War I. Choice (C) is supported by the use of the phrase wealth of examples to describe the work.
10. D The topic of the passage is Pickett's interpretation of American military history. In the second paragraph, the author states that while Pickett's work provides a refreshingly candid argument of why America goes to war, he overstates the case when he argues that these abstract causes typically lead to a war hysteria in which American leadership can no longer enforce any measured policies. In other words, while the author believes that some of the ideas Pickett presents are correct, the author also notes that Pickett's conclusions cannot be fully supported. The best answer is therefore choice (D). All the other answers are outside the scope of the passage. Additionally, choices (B) and (E) are extreme.
11. E The author discusses the ways in which Close's ideas of portraiture differ from tradition, and Close's emphasis on a head without expression or personality is the opposite of traditional portraiture. Choice (E) best addresses this uncommon approach. Choices (A) and (B) are not suggested in the passage. There is not enough information to support choice (C), and choice (D) is only partially addressed late in the passage.
12. B Choice (A) can be eliminated because, while the text tells you that the paintings are nearly indistinguishable from photographs, there is nothing that says anyone is confused by the paintings. Choice (B) is correct because the passage says, in line 17, that Close's later work found inspiration from abstract expressionism. Choice (C) is incorrect because the passage never states whether Close has sold his works.

13. B The second sentence of the passage provides Derrida's description of the concept of difference and includes attempts to discuss universal features of human nature are merely products of local standards. Thus the answer needs to make clear that acceptance does not equate truth. This is best summarized in choice (B). The other answers all discuss some aspect of the status quo, but none sufficiently debunk it as the accepted standard.
14. Derrida was considered the originator of a profound challenge... The credited response relates a view of Derrida as the originator of the anti-foundationalists' profound challenge to the history of human thought. The following sentences, though, put forth the view that the origin of anti-foundationalism is better traced to Darwin's theory of natural selection, which made the later movement almost an inevitable consequence.
15. A The author states that anti-foundationalists believe that there is no secure basis for knowledge. Therefore, choice (A) is correct. The author states that Derrida held the belief that any attempts to discuss universal features of human nature are merely products of local standards. In other words, meaning is understood within a cultural context, thus eliminate choice (B). Choice (C) misquotes the information in the passage. Though the passage talks about Darwin's work, almost making Derrida's inevitable, choice (D) is too extreme. Eliminate choice (E) because it does not address the question.

1. B The use of the word guise means that the talk stories are a way to convey other information, namely the myths of Kingston's cultural background. Choice (B) is the best answer because it paraphrases this point. Neither choice (A) nor choice (C) is mentioned in the passage.
2. A In the first paragraph the author notes that some readers categorize Kingston as a great Asian-American writer. The author follows this statement by referencing examples in her writing that support the contention, so the best answer is choice (A). The other choices are not supported by the passage. In addition, choice (E) is extreme in its use of the word unique.
3. A and B
 In the first paragraph the movement is described as a subtle rebellion, so the author sees literature as something that can be used as a protest as stated in choice (A). Choice (B) also works because the text tells you that while seventeenth-century France was characterized by political intrigue and violence, it also tells you that that same instability reawakened French proclivities for cultural expression and that by the time Louis XIV took the throne, society was primed for the reestablishment of the arts. Therefore, prior to the unrest of the seventeenth-century, the French had more involvement with the arts. Choice (C) can be eliminated because the wording is too strong and inclusive; literature was a form of protest available, but you do not know that it was the only form of protest.
4. A The passage is primarily concerned with how préciosité paved the way for a resurgence of interest in the arts in seventeenth-century France, which makes choice (A) the best answer. Though the passage does highlight the role of women in the Baroque movement, it does not attempt to make any larger statements about women in history, therefore, choice (B) is incorrect. The passage does define and explain the origins of a literary movement, but that is not the primary purpose, so eliminate choice (C). The primary purpose of the passage is not a discussion of how nations' rulers affect the arts, which makes choice (D) incorrect. Finally, choice (E) is not suggested in the passage.
5. C Choice (A) can be eliminated because the text tells you that préciosité came from a group of cultured and educated ladies, not the entirety of French society. Choice (B) can also be eliminated because of phrases such as men scoffed and often dismissed, which indicate that préciosité was mocked before Molière wrote his play. Choice (C) is the only statement supported by the text, as the references to the mocking show that no one at the time truly understood the cultural importance of what was going on.
6. Preferring appearance to substance and excess to moderation... While there are descriptions all throughout the text of both préciosité and neo-classicism, this sentence is the only one with the direct contrast. The passage tells you that the préciosité was fantastically embellished and witty in manner, and that the neo-classicism elevated simplicity and minimalism. However, it's only in the correct sentence from the first paragraph that the author directly contrasts the two styles.
7. A and B
 The passage states that President Polk had overstepped ... against Mexico. If Polk declared war against Mexico, then you know Lincoln did not start the war; choice (A) is supported by the passage. If Lincoln thought that Polk overstepped his constitutional boundaries, then that indicates he did not think that Polk had the legal right to declare the war. This provides support for the disagreement referenced in choice (B). Choice (C) is not supported by the passage and can be eliminated: The Civil War, not the Mexican-American war was fought ostensibly to abolish slavery.
8. D It is important to read the lines within the context of the passage. Earlier in the passage the author informs us that Lincoln felt disdain for the Mexican-American War. The author notes that given Lincoln's willingness to fight the Civil War, this seeming inconsistency bears some explanation. From this text, you can infer that one of the goals of both the Mexican-American War and the Civil War was to ensure a united country. Therefore, given that Lincoln supported the Civil War, you can assume that he had reasons for opposing the Mexican-American War on grounds other than unification. Therefore, the correct answer is choice (D).
9. Therefore, American businesses will predominantly opt for outsourcing... The author only once explains what type of jobs will be outsourced: repetitive tasks that can easily be brought back to the United States.
10. B The author's purpose is sometimes presented at the end of the passage, as is the case with this passage, which ends with [t]he growing emphasis on bringing down the cost of back office operations is bound to offer increasing scope for Indian firms to become involved in novel types of ever more complex business processes. Choice (B) presents the best paraphrase of this statement. Choices (A) and (C) are too broad; choices (D) and (E) are not supported by the passage.
11. A and B
 Be sure you understand what the question is asking: You need to look for what you can prove isn't going to happen in the text, despite the pressure to pursue cost-cutting measures. The passage states that American society remains uncomfortable shifting business tasks overseas. Therefore, the Indian firms would not perform all of the business processes, making choice (A) a valid answer. Choice (B) is also supported by the text, because American businesses opt for outsourcing ... tasks that can easily be brought back to the US. Choice (C) is not supported by the text, because India is not outsourcing tasks to American firms.
12. B The zooxanthellae need carbon dioxide for their survival, according to line 23, so choice (B) is correct. We know that the zooxanthellae benefit from their relationship with coral, but the passage never says that they couldn't live without coral, so choice (C) goes too far. Since the zooxanthellae are helpful to the coral, they cannot be parasitical, which rules out choice (D). The passage never says anything about camouflage, so choice (A) is out of scope. The last sentence of the passage says that if zooxanthellate populations continue to decrease without recovery, their host corals will eventually follow suit.... indicating that coral may die without

zooxanthellae, so choice (E) is incorrect.

13. B The pollutions referred to are described as anthropogenic; the root means that they are linked to humans. Thus choice (B) is the best answer. The pollutions are not linked to any other type of organism, so eliminate choices (A) and (D). Choice (C) is incorrect because overfishing, etc., is not an accident. Choice (E) is wrong because the pollutions are not natural.
14. The zooxanthellate invertebrates lose their concentration of pigmentation or die altogether when stressed, turning translucent and allowing the slightly darker coral skeleton to show through the decaying tissue.
- Concentration of pigmentation is another way of saying coloration. The sentence states that the zooxanthellae lose their concentration of pigmentation when stressed, which provides an explanation for their loss of their coloration.
15. C The third paragraph lists a number of factors that contribute to coral bleaching, including overharvesting coral for the exotic travel market. This supports the idea that tourist demand contributes to coral bleaching, thus making choice (C) the best answer. The passage says nothing about freight ships, fossil fuels, or governmental apathy, so choices (A), (B), and (D) can be eliminated. The third paragraph does suggest that coral is sensitive to natural climate changes, but it does not say that this sensitivity is unusual as stated in the answer, so choice (E) cannot be properly inferred from the passage.

1. B and C

The passage states that the origins of country music ... owe a great deal to African-American musicians, so that means that African-Americans were instrumental in developing country music; this supports the first part of choice (B). The passage also states that some of the “stars” of country music learned their trade from African-American musicians, implying that the African-American musicians taught them, completing the necessary support for choice (B). The last sentence of the passage states that in addition to jazz,...country music now clearly needs to be included in the list of musical genres that have an African-American lineage. This implies that jazz is already commonly acknowledged to arise from the African-American lineage, and this fact supports choice (C). Choice (A) is a trap answer; the passage says that Payne taught Williams, but it doesn’t specify exactly what he taught him.

2. A The line reference draws attention to the sentence naming some African-American musical traditions that shaped country music; thus, the answer needs to describe that relationship. Only choice (A) depicts this previous music as the source from which country music arose. There is nothing in the passage to support choices (B), (D), or (E). Choice (C) is true but does not answer the question.
3. B The preceding sentence (the one that details the possible steps in face perception) is a more specific description of the psychologists’ theory so eliminate choice (A). The author never provides the history described in choice (C) so it is also incorrect; he/she merely provides two arguments on the phenomenon. The author never discusses visual perception more generally; thus choice (D) goes beyond the scope of the passage. The author never reconciles the psychologists’ and cognitive neuroscientists’ views, and so choice (E) is not supported. Choice (B) is the best match.
4. A Analogy describes the way cognitive neuroscientists believe the brain functions when confronted with faces. In the following sentence the author discusses the way in which brains have a natural ability to recognize things of the same character or quality. Eliminate choices (B) and (D) because they discuss psychologists. Choice (C) is too unspecific, and choice (E) leaves out the comparison factor. The best match is choice (A) because it addresses the matching that neuroscientists think is happening.
5. A When looking for the main idea, you need to consider the entire passage. In the first paragraph the author states that some people had assumed that schools that were freed from rules and regulations (such as charter schools) would revolutionize education. In the second paragraph the author states that those who study educational reform have found that charter schools did not in fact have a revolutionary impact on education—either for better or worse—although students who attend charter schools sometimes do not seem to do as well academically. In the last paragraph the author talks about the challenges that schools face in general, be they charter schools or traditional schools. Choice (A) gets closest to summarizing the entire passage. Choices (B) and (E) contradict the passage, choice (D) is too extreme, and choice (C) is not the whole point.
6. It is, however, impossible to know whether this difference is due to... The critics, mentioned in the first paragraph, fear deleterious rather than beneficial effects ... on the academic achievement of students. The second paragraph discusses academic outcomes of charter schools, so that is where you should look for the answer. The first two sentences of the paragraph discuss the amount of impact charter schools have had, but do not make specific mention of bad effects. The third sentence provides factual evidence for the critics, but does not give the author’s opinion regarding this evidence. The final sentence of this paragraph is correct because in it, the author questions whether simply being a charter school is the reason that some schools do not meet state standards.
7. D At the end of the final paragraph the author lists the challenges that schools face. Choices (A), (B), (C), and (E) are paraphrases of these points. While the paragraph does discuss how student performance is measured, this information is not presented as a particular challenge that schools face; thus choice (D) is the best answer.
8. C Choice (A) is not supported; although college attendance may seem like a useful measure of academic achievement, choice (A) provides no information about students from traditional schools for comparison. Choice (B) is likewise not supported: Although having a new standard might eventually allow relevant information to be gathered, the simple creation of such a standard would itself give no way to differentiate between students at the two types of schools. Choice (C) is supported because the author uses state performance standards to assess academic performance in the second paragraph.
9. B Choice (A) can be eliminated because the wording is too extreme. While the study of memory is important, there’s no evidence that it’s the most important approach. No other approach is mentioned in the text. Choice (B) works well because the text tells you Proust is “widely recognized as an icon of French culture and literature” and that “many commentaries have focused on Proust’s treatment of ... memory.” Choice (C) can be eliminated because the second half of the answer cannot be supported. There is no evidence that studies on memory in Proust are no longer useful.
10. B The second paragraph focuses on Benhaïm’s study of Proust’s text. Because of Proust’s mysterious and, at times, hostile representations of French cities, the narrator is turned into an exile in his homeland. The quotation illustrates this point using the narrator’s perception of Balbec, which for him is strange and cruel. Choice (B) is the best match. Eliminate choice (A) because it uses information from the passage but doesn’t answer the question. Eliminate choice (C) because the author never discusses the realities of living in France. Choice (D) goes beyond the scope of the question, and choice (E) is unrelated to the quoted text.
11. C In the second paragraph, Proust describes “These strangely ordinary and disdainfully familiar cathedrals.” Choice (C) is the best answer because churches is another word for cathedral. You can eliminate choice (A) because the quote does not mention graves. Choice (B) could be attractive because the narrator is described as a stranger to his homeland and living the life of an exile, but Proust himself does not mention travelers as a feature of Balbec. Therefore, you can eliminate choice (B).
12. In his work, French cities are archaic and exotic. In the sentence before, the author says that Proust “describes France in ways that one

archaic or exotic. The final sentence shows Proust's assessment of French culture as a whole, but not his description of France itself.”

13. A Eliminate choice (B); while the author compares the Judeo-Christian concept of god with the Nahuas' belief in the sacred power of teotl, the author never discusses any Christian stories that explain the beginnings of the world. Teotl is not a concept in Western philosophy, so eliminate choice (C). Though the author's definition of teotl makes a comparison, one isn't supported over the other, eliminating choice (D). While this definition may spark curiosity, the role of this statement is not to advocate action, so choice (E) is eliminated. Thus, the best answer is choice (A).

14. B and C

The author spends the bulk of the passage discussing teotl, which is described as the core of their philosophy, so choice (C) is supported. Much of the passage also describes the ways in which the concept of teotl is distinct in nature from the concepts of Western philosophy, so choice (B) is supported. Choice (A) may seem like a logical inference, but the passage never explicitly discusses customs of the Nahuas, so choice (A) is not supported.

15. D Eliminate choice (A) because this answer clearly mixes up a couple of the central ideas in the passage. According to scholars, Nahua philosophy was complex and interrelated, but the author doesn't say that Western philosophy consists only of dichotomies, so eliminate choice (B) as this is an extreme answer. The first part of choice (C) is great, but the second part is very wrong; half bad is all bad, so eliminate it. Eliminate choice (E) because it is too extreme. Within the Nahuas' worldview, the supernatural force was united with the natural world, so choice (D) is the best match.

1. A and C

The passage says that scats provide crucial evidence regarding territory. This phrase indicates that the issue of territory is worth studying, so you know that choice (B) is true. Choice (A), however, is phrased in too extreme a form to be supported by the passage; additionally, the final sentence says that scent, vocalization, and aggressive displays also mark territory. That last indicator of territory, aggressive displays, also tells you that choice (C) is not supported. Therefore, choices (A) and (C) are the credited responses.

2. B

By saying that the wombat is not mythical, the passage suggests that someone must have thought that the wombat does not really exist; thus the correct answer is choice (B). This passage does not tie the wombat to the Eora culture, nor does it extend that culture to any other civilization, thus eliminating choices (A) and (C). The passage also does not provide any contrast with other rodents, so choice (D) is incorrect. Eliminate choice (E) because, while the passage addresses the derivative of the wombat's name, it does not refer to naming standards.

3. A

The right answer to a main idea question will cover the entire passage. This passage describes three theories for the cause of the Permian mass extinctions: asteroid impact, volcanic eruption, and rising concentrations of hydrogen sulfide in the earth's oceans. The first two of these theories are shown to be problematic. All you are told about the third theory is that it can be tested. The answer that best covers all three theories is choice (A).

4. B

According to the passage, the hydrogen sulfide theory could be tested by checking oceanic sediments from the Permian period for evidence of the proliferation of certain bacteria. If, as choice (B) suggests, the Permian period can't be distinguished from earlier periods, then it will be impossible to test for an increase in bacteria from that period. Choice (A), if anything, would strengthen the author's argument by making the Permian period more distinct; choices (C), (D), and (E) go beyond the scope of the passage.

5. A

Eliminate choice (B) because it is an extreme answer and not supported by the text. While Kahlo focused on self-representation, it is too much of a leap to infer that the Mexican revolution and/or nationalism were irrelevant to Kahlo's art. Eliminate choice (C) because it is too broad. This passage focuses on Kahlo and some of her male contemporaries, not female and male artists in general. The information about the war does not explain Kahlo's relative obscurity nor does it address issues of feminist beliefs, so eliminate choices (D) and (E). The correct answer is choice (A).

6. B and C

Go back to the text to see what the passage tells you about Kahlo's contemporaries: While she was painting self-portraits, they were more interested in public forms of art. Choice (A) is too extreme: There's no support for them never painting self-portraits. Choice (B) is supported because the fact that Kahlo did not achieve recognition until long after her death made her unlike her contemporaries. Choice (C) is supported by the end of the first paragraph: Her contemporaries' interest in public forms of art is explained by placing them in the time of the Mexican revolution ... a period that fostered an interest in nationalistic themes.

7. A and B

The final sentence of the passage indicates that transportation is a clear problem that limits consideration of terraforming to mere conjecture, so choice (A) is supported. Choice (B) is supported because the author is worried about the Martian atmosphere dehydrating again after the planet is made habitable. Choice (C), however, goes beyond the scope of the information presented in the passage: The previous existence of water and an atmosphere similar to that of earth does not necessarily mean that Mars hosted life.

8. A

One of the major obstacles to terraforming Mars as mentioned in the passage is the lack of a life-sustaining atmosphere; if the carbon dioxide layer were able to retain atmospheric heat, terraforming would be more feasible. Thus, choice (A) is the best answer. Choice (B) makes terraforming less feasible; without an atmosphere it would be inhospitable to man. Choice (C) makes terraforming neither more nor less likely—the point of terraforming is to change the environment. The passage is not concerned with governments on Earth, making choice (D) incorrect. Choice (E) is incorrect because the passage is not concerned with other planets.

9.

By 1926, speculating on pricing was a crime. The question asks for a description of an action undertaken by the Soviet government. Most of the third paragraph details the actions of the NEPmen. Line 27, The state could not produce consumer goods... is incorrect because it does not describe an actual action by the Soviet government, but describes an action the government could not do: producing enough goods. Line 35, Since the state could not produce or profit... is incorrect because, although it says that the state adopted measures, it does not specify what those measures were. By 1926, speculating on pricing was a crime is the answer because it specifies the action the Soviet government took against the NEPmen: It made speculation a crime.

10. D

Choices (A) and (E) can be eliminated, because the sentence does not refer to the government's view. Choice (B) may look attractive, but the word mistaken is too strong. Choices (C) and (D) are quite similar, so compare them to each other. The only real problem is that choice (C) says the crisis could have been averted. The passage does not say the crisis was preventable. Choice (D) is the best answer.

11. C

Choice (B) is too narrow because it refers only to the beginning of the passage. Choice (E) is too broad; only a few systems are mentioned and only one is the focus. Choices (A), (C), and (D) are similar, so compare them to each other. If you can't decide which one to choose, make a guess and move on. Choice (C) is best because it captures the real focus of the passage: why the NEP failed. Choice (D) is close, but the three crises ended a policy, not a whole era.

12. A and C

not supported by the text because the NEPmen were not solely responsible for the downfall of the NEP. Also, the

question asks about the author's opinions, and the description given of the NEPmen is that of popular opinion, not necessarily the author. Choice (B) is supported by the text in the second paragraph stating that the state could not produce or profit as well as the NEPmen. Choice (C) is not supported by the text. Although all the words in the answer choice look familiar, nothing about the context of the answer choice is actually in the text. The scissors crisis was actually caused by the NEP, not war communism, and it was caused by the government's spurring of industry, not agriculture. The correct answers are choices (A) and (C).

13. B According to the passage, the burning of fossil fuels, which have no carbon-14 content, has diluted the atmospheric carbon-14 content. Since carbon dating works by comparing the percentage of carbon remaining in an ancient object to that found in living matter, you would need to have a consistent ratio of carbon-14. Because the burning of fossil fuels has decreased that ratio, however, living matter that died prior to the burning of fossil fuels would have more carbon-14 content when it died, and would therefore appear to have died more recently. Choice (A) is the opposite of what you're looking for, so you can eliminate it. Choice (C) is not supported by the passage.
14. A In the first paragraph, the author discusses the trouble that anthropologists have had in dating the habilis skull, which at first they thought to be 3 million years old. In the second paragraph, the author describes how carbon dating techniques work; objects are dated by the ratio of carbon-14 they possess. However, the author goes on to show that the half-life of carbon can date objects only up to 50,000 years old, or 100,000 years at most if accelerator techniques are used. This limitation suggests that carbon dating is unsuitable for providing the exact age of the habilis skull, making choice (A) the best answer. Choice (B) is actually the opposite of what the author suggests for the time frame being discussed. Choice (C) does not answer the question; while the difference is indeed highlighted, this answer ignores the purpose of the contrast. In choice (D), accelerator techniques would still not be adequate to date habilis. Choice (E) is off the mark; the half-life in itself does not illustrate the equilibrium.
15. C The proposed solution comes at the end of the passage, where the author discusses radiometric dating methods, so the answer needs to address the requirements of this solution. There is an assumption in this method that the isotopes being measured decay at a consistent rate, and this issue is best addressed in choice (C). While choice (E) addresses radiometric methods, the author does not discuss the equipment involved in the process. The remaining answers do not cover this proposed solution.
16. However, the assumption that the decay... Be sure to read the question carefully: The author raises a number of possible objections to carbon dating, but only the final paragraph discusses proposed alternatives. The last sentence, the credited response, points out that these alternatives may have the same problem as the carbon dating: inconsistent decay rates.



Sentence Equivalence

The directions for Sentence Equivalence state: Select the two answer choices that, when used to complete the sentence, fit the meaning of the sentence as a whole and produce completed sentences that are alike in meaning.

In other words, figure out the story being told and pick the two words in the answer choices that complete the story in the same way. These are like Sentence Completion questions you might remember from the SAT or previous versions of the GRE, but you are picking two words rather than one for the same blank.

A word of warning on Sentence Equivalence: Beware of the answer choices. They will always fit grammatically into the sentence, and most of them will sound pretty attractive. Just remember that the answer choices represent ETS's "suggestions" for what to put in the blank. We don't like their suggestions, we don't trust their suggestions, and we don't want their suggestions. The answer choices have been carefully selected and then tested on thousands of students for the sole purpose of messing with your head. The first step on Sentence Equivalence is always to cover up the answer choices. Literally put your hand on the screen, and don't let them pollute your thinking.

Think of the sentence itself as a mini Reading Comprehension passage. Before you do anything, find the main idea. Who is the passage talking about? What are we told about this person or thing? Once you have the story firmly in mind, come up with your own word for the blank, and eliminate the answer choices that don't match.

THE PROCESS

Step 1—Cover the answer choices.

Step 2—Find the story. Who is our main character? What are we told about the main character?

Step 3—Come up with your own word for the blank. Don't look at the answer choices. Force yourself to come up with your own word based upon the information in the passage.

Step 4—Process of Elimination (POE). Use your word to eliminate answer choices. Look at each answer choice and ask whether it matches your word. If not, get rid of it. If the answer is "I'm not sure," give it the maybe and move on. If the answer is yes, give it the check. Make sure that all of this work takes place on your scratch paper.

FINDING THE CLUE

The "Clue" is that part of the sentence that tells you what to put in the blank. Every sentence must have one because it's the part of the sentence that tells you whether an answer choice is right or wrong. The clue is like an arrow that points only to right answers. Finding the clue is the key to coming up with your own word and eliminating wrong answers!

TRIGGERS

Imagine a conversation that begins, "That's Frank. He won the lottery and now ____." Something good is going to go into that blank. Frank could be a millionaire, could be living on his own island, or could be a great collector of rare jeweled belt buckles. Whatever it is, this story is going to end happily.

Now consider this story: "That's Frank. He won the lottery but now ____." This story is going to end badly. Frank could be tied up in court for tax evasion, panhandling on the corner, or in a mental institution.

The only difference between these two stories are the words but and and. These are triggers. Here are some of the triggers that show up on the GRE most frequently.

but	in contrast
although (though, even though)	unfortunately
unless	heretofore
rather	thus
yet	and
despite	therefore
while	similarly
however	; or :

When it comes to Sentence Equivalence, remember these three things:

1. Invest your time in the sentence. Stick with the sentence until you find the story. Don't even think about looking at the answer choices until the story is crystal clear.

2. Your word is your filter. Come up with your own word for the blank and use it to eliminate answer choices. Actively identify and eliminate wrong answers. Keep your hand moving on your scratch paper. If it takes more than a few seconds to decide whether to keep or eliminate an answer choice, give it the maybe and move on. Note: If an answer choice has no synonym among the other answer choices, it's unlikely to be correct.
3. Mark and Come Back. If a sentence isn't making sense, or none of the answer choices look right, walk away. Don't keep forcing the sentence. You may have read something wrong. Do a few other questions to distract your brain, and then take a second look at it.



Sentence Equivalence Drills

Question 1

Despite their initial fears, most environmentalists now concede that the artificial reefs have had a largely ____ effect on surrounding ecosystems.

- unfounded
- benign
- caustic
- interminable
- innocuous
- plaintive

Question 2

Scholarship reductions and player defections notwithstanding, the new coach applied himself to rebuilding the program with such ____ that the rest of the staff struggled to match his enthusiasm.

- cessation
- indifference
- rhetoric
- fervency
- heedlessness
- zeal

Question 3

After hours of practice and innumerable fruitless attempts to catch the balls, Allen was finally forced to admit that he wasn't sufficiently ____ to be a juggler.

- sedate
- lumbering
- dexterous
- implicit
- adroit
- awkward

Question 4

The cohesion of Alexander the Great's vast empire was ____; at his death, Alexander's lands were divided among his generals, Ptolemy, Seleucus, and Antigonus the One-Eyed.

- abiding
- precarious
- protracted

- renowned
- tenuous

Question 5

His wife's icy stare and aloof demeanor told Johann unequivocally that his propitiatory gifts had failed to ____ her anger.

- vilify
- garner
- exacerbate
- aggravate
- placate
- appease

Question 6

By consuming ____ numbers of power bars, some athletes believe they will have proportionally greater amounts of endurance and strength because of the energy-producing ingredients these products claim to contain.

- scant
- furtive
- copious
- solvent
- measured
- profuse

Question 7

The comprehensive bill, signed into law by the president late last week, was ____ 249 new regulations on the fishing industry.

- elucidated by
- rife with
- deficient in
- unencumbered by
- replete with
- exempted from

Question 8

The former employees started a blog that revealed the embarrassing quirks of the boss, an act which had ____ impact on the company's CEO.

- a virulent
- an assuaging
- a monumental

- a bolstering
- a mortifying

Question 9

The late Samuel Huntington was well known for his ____ opinions on relations among different cultures; many of his ideas are still passionately debated today.

- zealous
- pedantic
- polemical
- rhetorical
- divisive
- hegemonic

Question 10

The ____ plant life on the previously barren volcanic rock created by the Kilauea lava flow is strong evidence that humans, too, will one day be able to inhabit the area.

- incipient
- nascent
- waning
- fervent
- flagging
- static

Question 11

Regardless of the long-winded answers Michael consistently gave in class, his teachers remember him as ____ student, rather than a garrulous one, because he generally kept to himself.

- a taciturn
- a voluble
- an uncommunicative
- a querulous
- a disinterested
- an eccentric

Question 12

For the cities at the foothills of the Rocky Mountains, where the shortage of rain often leaves wells and rivers empty, a winter without liberal snowfall will mean a ____ of the run-off that normally provides fresh water in the summer months.

- proliferation
- conduit

- paucity
- surfeit
- dearth
- burgeoning

Question 13

Despite her father's endeavors to placate his daughter every time she had a grievance, the young girl was simply ____ complainer, and so could always find something else that displeased her.

- an inveterate
- an impertinent
- a plaintive
- an oblique
- a chronic
- an abysmal

Question 14

Few want to believe that Lisa de Giocondo, the woman popularly believed to have been the model for da Vinci's Mona Lisa, was a(n) ____ person and prefer instead to think that there is an enigma behind the celebrated smile.

- dulcet
- artless
- comely
- facile
- inscrutable
- ingenuous

Question 15

Though the futurist conceded that Apple's iPhone was a revolutionary device, she was adamant that it would not be immune to the same forces that caused such previous "game changing" products as Ford's Model T and Sony's Walkman to be considered ____.

- avant-garde
- electronic
- circuitous
- antediluvian
- superannuated
- radical

Question 16

The results of a survey of movie-goers gainsaid the scholar's claim that the filmmakers' intent would remain opaque to most viewers; it seems the metaphors employed were rather ____.

- abstruse
- manifest
- aesthetic
- cryptic
- recalcitrant

Question 17

To call the area ____ was perhaps hyperbolic; while it was quaint and abstracted from the modern life of nearby cities, the presence of mining equipment was decidedly imposing.

- germane
- gentrified
- aplomb
- bucolic
- rancorous
- quiescent

Question 18

In an era in which mass media is but a thrall of its corporate masters, the amateurish ____ of commercials for local businesses provide a tonic for the slick homogeneity of most advertising.

- amalgamations
- eccentricities
- synergies
- conglomerations
- syllogisms
- idiosyncrasies

Question 19

Despite having earned over two hundred million dollars during his career, the boxer's ____ spending and bad investments left him insolvent within a few years of retirement.

- parsimonious
- penurious
- perfidious
- prodigal
- profligate
- pugnacious

Question 20

When a Roman emperor visited a provincial city, an important part of the ceremony of receptio was the delivery of ____, in which a

local poet or orator would lavish praise on the imperial visitor.

- a compendium
- an elegy
- an encomium
- a jeremiad
- a philippic
- a panegyric

DRILL 2

Question 1

Despite having steeled herself for the worst, the new band director was disheartened to hear the ____ sounds emanating from the freshman orchestra.

- arduous
- euphonious
- cacophonous
- ample
- discordant
- harmonious

Question 2

Bede, the author of A History of the English Church and People, was so widely ____ that he has been almost universally known as “The Venerable Bede” since the ninth century.

- defamed
- consoled
- revered
- esteemed
- mitigated
- reviled

Question 3

In addition to the detailed written regulations regarding play, a novice golfer must also learn the ____, but nonetheless important, rules of etiquette.

- implicit
- laconic
- express
- tacit
- reclusive
- manifest

Question 4

Based on the desire to restrict further water pollution, the Clean Water Act of 1972 began under ____ terms, but opponents soon assailed the bill in the court system and discouraged those who had fought for its ratification.

- bleak
- auspicious
- unfavorable

- suspicious
- promising
- ineffectual

Question 5

Jane Austen's novel, Emma, paints a comedy of errors that results when its heroine tries her hand at creating love matches, an effort which she attributes to her own ____ instead of a selfish need to meddle.

- gaiety
- benevolence
- elegance
- viscosity
- refinement
- magnanimity

Question 6

While interviewing for a job as a computer consultant, Robert consciously provided a ____ of references, knowing full well that he had few former employers who would be laudatory about his past projects.

- multitude
- array
- myriad
- potpourri
- paucity
- dearth

Question 7

While most of the tasks undertaken by the interns were undemanding, a fact that led to the flood of applicants for the positions each year, there was one ____ duty: cleaning out the garbage bins in the laboratory.

- unambiguous
- facile
- arduous
- onerous
- tenebrous
- lucid

Question 8

In an attempt to ____ voters to support her, the incumbent politician beguilingly greeted a room full of constituents and pledged to lower taxes—even though she had only ever done the opposite while in office.

- alienate

- inveigle
- eviscerate
- estrange
- entice

Question 9

After a series of storms, the once arid landscape became ____ for the first time in many months.

- innocuous
- barren
- verdant
- desolate
- bountiful
- limpid

Question 10

Although he received many visitors, the ____ old man shooed them away after only a few minutes.

- misanthropic
- curmudgeonly
- sarcastic
- chauvinistic
- garrulous
- affable

Question 11

Eileen used to be a picky eater, but since a new complex of fine dining and ethnic restaurants opened in her neighborhood, she has become quite ____.

- corpulent
- finicky
- epicurean
- ponderous
- gourmandizing
- persnickety

Question 12

The SWAT team entered the dark building on high alert, their guns drawn and their night vision goggles on; each agent's eyes and ears were attuned to the slightest disturbance in the ____ recesses of the rooms.

- empty

- stygian
- gloomy
- functional
- useful

Question 13

Under no delusions about his actual financial situation, the man's desire to present a frugal picture to his friends and avoid being labeled ____ caused him to go to such an extreme that he ended up being called a Scrooge.

- a spendthrift
- a prodigal
- a miser
- a hedonist
- a skinflint
- an epicure

Question 14

The ____ pirate plundered every trade ship that came near his own ship; it was almost as if he could never loot or pillage enough to satisfy his craving for gold and jewels.

- raffish
- ebullient
- voracious
- showy
- rapacious
- effusive

Question 15

The homicide detectives didn't truly understand the ____ of the criminal until they found the secret hideout where he stored his instruments of torture and carried out his heinous acts.

- pulchritude
- enormity
- ingenuity
- iniquity
- canniness
- perfidy

Question 16

While blood and human sacrifices performed to mollify the gods were ubiquitous in ancient cultures, the Mayans' propensity for sacrificing prisoners from neighboring tribes ____ all the other tribes.

- imprisoned
- engendered
- disquieted
- expatiated
- condoned
- affronted

Question 17

In contrast to the stark facades of their surviving ruins, medieval castles were depicted in contemporary tapestries as ____ with colorful banners and pennants.

- ablated
- attenuated
- bedizened
- caparisoned
- extirpated
- fomented

Question 18

The young minister was startled to learn that his parishioners considered him ____; he had been unaware that his message was being undermined by his sanctimonious and self-righteous tone.

- ingenuous
- moralistic
- punctilious
- salacious
- sententious
- unaffected

Question 19

Many senior faculty members who were accustomed to being addressed in a more collegial and egalitarian manner were alienated by the ____ tone of the new department chair's introductory remarks.

- ignominious
- imperious
- peremptory
- propitious
- sanguine
- saturnine

Meant to demonstrate an air of sophistication and worldliness, the comments that Hannah made upon exiting the building served only to emphasize her ____ mentality and reinforce Mr. Hassan's conviction that her dismissal was justified because she was not yet mature enough for the corporate world.

- adroit
- venal
- puerile
- callow
- indolent
- audacious

DRILL 3

Question 1

Sylvia Plath was not as ____ a poet as was her husband Ted Hughes, having produced just two volumes of poetry in her short lifespan.

- dejected
- celebrated
- satiric
- jubilant
- prolific
- fruitful

Question 2

The unfounded fear that some children, and even adults, have of the circus clown is rather ironic considering that he is meant to be ____ character who invokes laughter and enjoyment.

- an ace
- a surly
- a genial
- an artful
- a crackerjack
- an affable

Question 3

The photographer ____ posed the bride for her portrait, carefully adjusting each fold of her dress and each curl of her hair before taking the picture.

- meticulously
- frantically
- subversively
- hectically
- fastidiously
- hysterically

Question 4

After finishing the editing workshop, the writers found that they were able to give each other ____ comments, instead of the general and unhelpful suggestions they had been making beforehand.

- cursory
- derisive
- superficial

- critical
- constructive

Question 5

Many admirers of art ____ the beauty of Jackson Pollock's paintings, while others disparage the splatters of color as simplistic.

- defame
- overlook
- ignore
- commend
- underrate
- extol

Question 6

Expecting Tom to protest the poor grade on his psychology paper, the professor was disheartened when he ____ tossed it in his bag and left the room.

- gingerly
- flippantly
- timidly
- prudently
- thoughtlessly
- delicately

Question 7

The stock market having plunged drastically, the investor's ____ mood on the trading floor seemed incongruous.

- enervated
- sanguine
- inconsolable
- sardonic
- funereal
- buoyant

Question 8

Hundreds of ____ fans waited in line for hours at the comic book convention to talk to their favorite artists and buy limited-edition toy variants otherwise unavailable.

- staunch
- malodorous
- hirsute

- zealous
- noisome
- impecunious

Question 9

The group's final paper, replete with errors in spelling, diction, and idiom, showed every sign of having been given only ____ proofreading.

- an artless
- a cursory
- an extraneous
- a fastidious
- a meticulous
- a perfunctory

Question 10

Releasing a series of solo recordings, collaborating with such musicians as David Byrne and Robert Fripp, and producing artists from Devo to U2 made Brian Eno so ____ for a time that one music industry observer was moved to note that "Brain Eno is everywhere—like God, or salt."

- omnivorous
- ignoble
- fortuitous
- omnipresent
- odious
- ubiquitous

Question 11

Some of Dr. Seuss's most famous characters had ____ meanings that would be lost on his young readers until adulthood; the title character in Yertle the Turtle, for instance, was based on Hitler, and the imperiled Who people in Horton Hears a Who represented the citizens of post-World War II Japan.

- banal
- manifest
- oblique
- nascent
- allusive
- lucid

Question 12

Oblivious to the magnitude of his costly mistake, Whitman was unprepared to be ____ at so public a forum as the annual shareholder's meeting.

- censured

- excoriated
- instigated
- lauded
- repatriated
- extolled

Question 13

Because they were written to entertain both parents and children, Looney Tunes and Merrie Melodies served an unexpectedly ____ purpose: vex, parry, and overture, for example, are among the advanced vocabulary that the young audience could learn in context from The Bugs Bunny Show.

- didactic
- obfuscating
- edifying
- aggrandizing
- ephemeral
- mystifying

Question 14

Not known to go out of his way to get along with people, the reclusive author nonetheless managed to surprise the interviewer with his ____ comments.

- simpatico
- abstruse
- recondite
- splenetic
- winsome
- churlish

Question 15

The decision to continue the investigation was not so much about doubting the veracity of the witness's statement, which had been corroborated by other reliable interviews, as it was about a conviction that there was further evidence that could play a ____ role in the case.

- paramount
- negligible
- salient
- perjurious
- mendacious
- marginal

Boycotting companies that engage in unethical behavior, such as promoting wars or violating privacy rights, can be an effective way to pressure corporations to stop inherently unacceptable behaviors; nonetheless, such demonstrations of consumer _____ can also have negative consequences including inflation and increased unemployment.

- endorsement
- ratification
- censure
- debilitation
- machinations
- disapprobation

Question 17

Instead of saying “killed” when reporting on war situations, the military often uses more anodyne phrases such as “neutralizing the target” or “collateral damage;” these attempts to gloss reality with _____ do nothing to alleviate the impact of the news.

- elucidation
- periphrasis
- prevarication
- circumlocution
- hyperbole
- dysphemisms

Question 18

Truly understanding literary theory requires a greater academic investment than simply memorizing descriptions of aestheticism, deconstructionism, and post-modernism; one must also be willing to study philosophy, history, and society to develop an interdisciplinary _____ of how humans build meaning.

- discernment
- incognizance
- acumen
- somnolence
- nescience
- belletrism

Question 19

Many animals such as the poison dart frog, the tiger moth, and the black widow spider give predators advanced warning of their unpalatability or danger through aposematic warning signs, while other animals such as the harmless scarlet kingsnake simply mimic the bright colors of the _____ species to keep predators away.

- pernicious
- amicable
- comestible
- pulchritudinous

deleterious

esculent

Question 20

While some mummies, those of Egyptian pharaohs for example, were intentionally preserved with substances such as natron to dry out the bodies and prevent decomposition, others, such as the Tarim mummies found in present-day Xinjiang, China, were _____ naturally by the searing desert conditions.

smelted

disinterred

espied

vitiated

exsiccated

anhydrated

DRILL 4

Question 1

As the valedictorian of his graduating class, Thomas was tasked with delivering a(n) ____ speech, dutifully rehearsing in front of both his mirror and the cat.

- languid
- extended
- eloquent
- listless
- articulate
- enduring

Question 2

Worried that he had lost the support of his party, the Prime Minister forcefully ____ his controversial statement that healthcare would not be a priority.

- recanted
- affirmed
- validated
- overlooked
- disavowed
- ignored

Question 3

With recent advances in technology allowing for convenient online access to reading material, many forecasters expect to see hardcover book sales ____.

- multiply
- abate
- prevail
- assimilate
- dwindle
- appreciate

Question 4

Pulled over for speeding and nervous about receiving an unpleasant lecture, Natalie's fears were easily relieved by the ____ policeman.

- exacting
- affable
- atypical

- stringent
- sober
- genial

Question 5

Even among statisticians, who fully understand that true randomness includes repetition, there is often a misguided attempt to ____ one's chances of winning the lottery by declining to select numbers that have recently appeared on winning tickets.

- augment
- escalate
- divulge
- mitigate
- squander
- curtail

Question 6

“Out of sight, out of mind” is a useful ____ for those who cannot develop a logical argument to defend their failure to be concerned about poverty in foreign nations.

- fallacy
- allusion
- maxim
- query
- waiver
- proverb

Question 7

Although it initially seemed that the ideological gap between them was insurmountable—he believed in ____ while she believed in accumulating wealth, he in sensitivity towards others while she in self-interest—the marriage ultimately lasted 52 years until his death.

- largess
- avarice
- empathy
- parsimony
- cupidity
- philanthropy

Question 8

Those who criticized Coco Chanel's later clothing designs misjudged as ____ the style that generations of women to come would regard as the epitome of high fashion.

- defamatory

- contrite
- mundane
- insipid
- exorbitant

Question 9

Since receiving a promotion to departmental chair, Brookstone has been even more prone to ____ against the university's administration, and consequently has lost several professional allies.

- approbations
- tirades
- diatribes
- precursors
- commendations
- canons

Question 10

Sergei's belief in astrology, a pseudoscience whose practitioners provide results that can never be conclusively proven or falsified, left him vulnerable to ____.

- censure
- chicanery
- vindication
- authentication
- wile
- vexation

Question 11

The ____ international aid agencies have toward selecting a fresh cause to champion approximately every five years is indicative of their desire to avoid apathy due to overexposure and, instead, continue to stimulate donor interest.

- ambivalence
- predilection
- affectation
- propensity
- wariness
- callousness

Question 12

Discussions about the use of high-fructose corn syrup as a sweetener lead to ____ among nutritionists, and the use of aspartame, which is also common, is just as controversial.

- concurrence
- gratification
- dissension
- veracity
- convergence

Question 13

Further recognition of the destructive effects of targeting fast food advertising at young children may lead to more efforts to ____ such tactics: there is already clear evidence that the necessary prohibitive regulations have widespread support.

- rally
- check
- embellish
- curb
- pirate
- muster

Question 14

Even though the judge personally found the law ____, his moral objection did not provide a legal basis on which to rule the law unconstitutional.

- anodyne
- abhorrent
- propitious
- permissible
- invidious
- salubrious

Question 15

Completely impenetrable to the layperson, the ancient text was ____ even to experts in the field.

- abstruse
- unequivocal
- opaque
- lucid
- incontrovertible
- obtuse

Question 16

The feudalism practiced by Carolingian rulers was still in its ____ stage; only later did features such as subinfeudation and the www.ztcprep.com of designating a liege lord lead to the fully-developed system familiar to students of the High Middle Ages.

- refractory
- byzantine
- nascent
- labyrinthine
- inchoate
- perfidious

Question 17

A key element of The Smiths' recognizable sound came from the tension between Morrissey's ____ lyrics and the cheerful, almost bouncy music composed by Johnny Marr.

- lubricious
- euphoric
- sanguine
- saturnine
- recondite
- lachrymose

Question 18

The bride was mortified to learn that her dress—which had appeared delicate, even ____, in the artificial light of the boutique—was nearly transparent in the bright sunlight of her outdoor wedding.

- ephemeral
- diaphanous
- ponderous
- mettlesome
- cumbersome
- gossamer

Question 19

The public's fascination with celebrities coupled with the innovations of the electronic age may inspire a new cadre of amateur "paparazzi": there are certainly indications that such a trend is ____.

- looming
- attenuating
- calumniating
- deliquescing
- flagging
- impending

The doctor's real mistake, from the perspective of his ____ professional friends who quickly jilted him, was not that his choice of treatment was inappropriate, but rather that it was viscerally objectionable to the medical establishment.

- squeamish
- fickle
- staunch
- inconstant
- orthodox
- stodgy

DRILL 5

Question 1

By reordering the sentences in the problem and adding distracting figures, the professor successfully ____ a previously easy exam question and made it almost impossible to solve.

- engendered
- muddled
- interpreted
- erased
- obliterated
- obfuscated

Question 2

Because she always had the correct answers to life's difficult dilemmas, my grandmother was sought after for her ____ by family members and neighbors.

- duplicity
- wisdom
- bewilderment
- ignorance
- sagacity
- guile

Question 3

The ____ road, made what seemed like a short trip on a map much longer in reality; it twisted its way through mountains to get from one valley to another.

- abbreviated
- invigorating
- fleeting
- immense
- serpentine
- tortuous

Question 4

Classmates who had pre-judged Lucy as unaware were surprised when she made the ____ observation that their professor's missing coffee mug indicated that he had left for the day.

- asinine
- perceptive
- obtuse

- transparent
- astute
- lucid

Question 5

Madeline's guests all agreed that had it not been for the terrible weather, her wedding day, complete with white dress and three-tiered cake, would have been ____.

- urban
- divine
- excessive
- disproportionate
- idyllic
- rustic

Question 6

The Shakespeare scholar argued that in all of the playwright's 37 works, he had never written the part of a ____ character, only relying on vibrant and colorful individuals to propel his stories forward.

- pedestrian
- original
- imperial
- domineering
- extraordinary
- mundane

Question 7

The intricate, complex photographic process of the daguerreotype contributed to the rapid development of numerous related processes, a ____ that included tintypes and calotypes.

- proliferation
- stagnation
- primogenitor
- archetype
- antiquity
- burgeoning

Question 8

The athlete, once well respected for his work with the anti-drug programs, was scorned for his ____ nature when medical tests proved he'd been using steroids for years.

- esteemed

- sanguine
- disingenuous
- buoyant
- duplicitous

Question 9

The protestors acknowledged the leader's appeal to ____ violence, and walked quietly in the funeral processions instead of throwing rocks at police officers.

- mollify
- abjure
- eschew
- condone
- glorify
- manifest

Question 10

Diecast truck manufacturers release limited edition models and others with obscure commercial advertising in order to ____ their trucks and ensure that certain items become dedicated collectibles instead of toys.

- rarefy
- circulate
- investigate
- subtilize
- spur
- incite

Question 11

The phacellophora camtschatica, which can grow up to two feet in diameter, is more commonly referred to as the Fried Egg jellyfish because of its white bell and cloudy yellow organs, which give its tentacles a ____, semi-transparent look.

- caustic
- resplendent
- natatory
- diaphanous
- calamitous
- gossamer

Question 12

Before the Clone Wars, the Jedi were a powerful peace-keeping force in the galaxy, but they were unable to avoid ____ after Palpatine called out Order 66, which reprogrammed every clone trooper to immediately assassinate his Jedi masters.

- sovereignty
- annihilation
- ingenuity
- misrepresentation
- ascendancy

Question 13

Hollywood studios, usually guided by their penchant for hiring A-list movie stars, are rethinking their strategies in an economy more suited to hiring ____ actors who command far less per picture than their celebrity counterparts, who can cost studios upwards of 15 or 20 million dollars for one movie.

- luminary
- renowned
- fledgling
- neoteric
- exorbitant
- iniquitous

Question 14

Joseph was never outwardly perturbed by bad news, and was known as the ____ of composure.

- quintessence
- bane
- rector
- epitome
- antithesis
- regent

Question 15

The President could not tolerate dissent from his views, and so he only appointed people to his cabinet who were more ____ than advisors.

- pundits
- sycophants
- cynics
- toadies
- partisans
- authoritarians

Question 16

www.ztcprep.com
 She was so impressed that her career may have prematurely reached its ____ after reading the encomium with which her first

publication was met.

- apogee
- auspice
- coda
- nadir
- perigee
- zenith

Question 17

The philosopher's arguments were so ____ that it was nearly impossible to follow the logic from his premises to his conclusion.

- rhetorical
- libertine
- labyrinthine
- unscrupulous
- byzantine
- decorous

Question 18

After his embezzlement was discovered, the CEO was ____ by board members, shareholders, and customers alike.

- cachinnated
- blandished
- upbraided
- simpered
- caviled
- lambasted

Question 19

While the new bistro's service was absolutely punctilious, the cuisine was rather ____.

- obsequious
- quotidian
- distasteful
- pedestrian
- gustatory
- pedantic

Question 20

After mispronouncing the name of the leader of an allied nation, the Secretary was quite ashamed; she had never before heard such

_____ levied against her as the leader's angry response.

- a laudation
- a dictum
- a panegyric
- an approbation
- an invective
- a vituperation

DRILL 6

Question 1

The con artist was so ____ that he most often left his victims feeling pleased that they had given him their money.

- innocuous
- crafty
- cunning
- maladroit
- discrete
- unskillful

Question 2

Although the book reveals some surprising information about the sharp-eyed Secret- Service employees, most people already know that such people are far more ____ than the average citizen.

- potent
- robust
- weary
- vulnerable
- vigilant
- mindful

Question 3

The ____ at the gala was not conducive to enjoyment; the presence of many direct political rivals filled the air with tension.

- decor
- discourse
- ambience
- etiquette
- atmosphere
- diversion

Question 4

It is generally assumed to be ____ to increase taxes on the middle class without a proportional increase on the taxes of the upper class as well.

- untenable
- sporadic
- indefensible
- subtle

- dignified
- pardonable

Question 5

It is difficult to provide ____ proof for the existence of ghosts and other spiritual beings that remain unseen by the majority of the population.

- indisputable
- daunting
- uncanny
- momentous
- skeptical
- demonstrable

Question 6

The politician insisted that he did not seek to enrich himself during the campaign, but the ethics committee concluded that he was motivated by ____.

- charity
- greed
- estrangement
- avarice
- compassion
- apprehension

Question 7

The calamitous event transformed the once unspoiled seascape into the very embodiment of ____.

- cataclysm
- conflict
- determination
- melancholy
- tenacity
- obliteration

Question 8

The company's new president immediately embarked upon a strategy of reorganization, but informed investors that these steps, while the most ____ and therefore undertaken first, would be among many required to turn the company around.

- unappealing
- trivial
- paramount

- exigent
- dispassionate
- insipid

Question 9

Concerned about being assigned the job of analyzing a poem which might be esoteric in meaning, Erika was delighted to be given instead Roethke's "The Waking," the ____ of which she embraced.

- cadency
- ambiguity
- cogency
- melancholy
- lucidity
- opacity

Question 10

To highlight Albert Einstein's image as a ____ scholar, there is an exaggerated tale floating around that his request to shut a window was the first sentence he had uttered in five years.

- loquacious
- consummate
- reticent
- judicious
- laconic
- garrulous

Question 11

Concerned about the noxious effects of pesticides on local rivers, Tess petitioned her local farmers to employ ____ amount of the repellent.

- a capacious
- an abiding
- a nominal
- an enduring
- a negligible
- a profuse

Question 12

Despite his lack of education and somewhat obtuse demeanor, the night watchman was relied upon by many for his ____ advice on matters of love and romance.

- insightful

- pragmatic
- vapid
- expedient
- perspicacious

Question 13

Due to the transient nature of her career, Emily could not guarantee that she would get an immutable paycheck every two weeks, and therefore warned her husband that he would need to ____ overtime work from his supervisors.

- rebuke
- amass
- eschew
- garner
- relinquish
- disseminate

Question 14

Throughout the mid-2000s, many corporations viewed internet applications such as personal email and social media as detractors from productivity; however, most businesses have now embraced the power of these applications not only to ____ productivity, but also further their brands in the marketplace.

- bolster
- engender
- vilipend
- ameliorate
- depreciate
- supplant

Question 15

Darryl argued that the poet's latest volume was ultimately ____, containing no new ideas, indeed nothing but overt drivel.

- platitudinous
- natty
- jejune
- labyrinthine
- lax
- amorphous

Question 16

In Jay Gatsby, Fitzgerald has created a conundrum of a character: as he grows progressively more flagrant in his spending and his lifestyle, Gatsby also becomes progressively more charming such that readers are forced to simultaneously admire and abhor his ____.

- dissipation
- repute
- volubility
- profligacy
- stature

Question 17

Animated and ____ by the ideals of the Enlightenment, the political unrest that began the French Revolution eventually erupted into anarchy.

- obliterated
- fomented
- galvanized
- paralleled
- exemplified
- extirpated

Question 18

A good editor must be able to quickly ____ excellent submissions from a pile of dross, distinguishing the best offerings from the worst in an efficient manner.

- consolidate
- integrate
- finagle
- intimate
- winnow
- sift

Question 19

In her recent book *Palmeriste: A Biography*, Sklar argues that Palmeriste was a connoisseur of many things, rather than a dilettante; Brand believes this is a ____ distinction, obscuring the more relevant question of where exactly he got all of his money.

- critical
- cardinal
- nice
- baleful
- minute
- feckless

Question 20

Because of their jargon, theorists often rely on jargon, their writing sometimes seems ____ to the general public, who cannot understand a

word of it.

risible

vapid

muddled

abstruse

occult

uncanny

DRILL 7

Question 1

By the third day of being sick with the flu, her feelings of ____ were so strong, all she could do was lie on the couch, unable even to get up to shower.

- vitality
- innuendo
- lethargy
- freshness
- hunger
- weariness

Question 2

When he fell into the pit of vipers, Jake was instantly ____ about the possibility of getting bitten by a poisonous snake.

- distressed
- apprehensive
- amazed
- ambivalent
- optimistic
- equivocal

Question 3

Jane was so passionately insistent on her assertions during the negotiation that her ____ tone was noted as the main reason her team prevailed.

- compromised
- adamant
- unusual
- unsteady
- unwavering
- vacillating

Question 4

When the 25 dogs and cats escaped for the third time that month, the mayor publicly expressed his ____ regarding the clear and ongoing mismanagement of the city kennel.

- discontentment
- approval
- contempt

joy

lethargy

Question 5

The young employee was more ____ by his new assignment than he seemed to be, for his confusion was disguised by his confident smile.

perturbed

discomposed

placated

vilified

conciliated

belabored

Question 6

Compulsory math and science courses are ____ requirements for many liberal arts students whose minds are more attuned to philosophical debate.

facile

stupefying

meticulous

elementary

exacting

onerous

Question 7

As ____ a dancer as she was, at least in the opinion of the general public, her failure to have trained at the illustrious Kirov School of Ballet precluded her from achieving the coveted title of prima ballerina assoluta.

perfunctory

evanescent

consummate

fulsome

noisome

virtuoso

Question 8

After months of research, the degree candidate was confident in the validity of her thesis, but certain key errors in methodology left the review committee ____.

persuaded

mollified

dubious

- irked
- convinced
- incredulous

Question 9

Because the discovery of the ancient letters _____ the historian's claims about the inhabitants of that time, the historian must reconsider the premises of his life's work.

- innervates
- belies
- corroborates
- controverts
- anticipates
- validates

Question 10

The theater critic made an appeal in his most recent review for playwrights to avoid _____ characters and situations, for he could not sit through one more trite play.

- judicious
- banal
- rapturous
- expedient
- entrancing
- pedestrian

Question 11

Consider the _____ of the nature of war, the outcome of which can hardly be considered favorable even for those who emerge victorious.

- enormity
- exposition
- bombast
- austerity
- depravity
- hegemony

Question 12

The legitimacy of a fledgling political party is highly dependent on the decorum of its members, since the _____ behavior of any one person can be used to disparage an entire movement.

- garrulous

- debauched
- reticent
- profligate
- cogent
- capricious

Question 13

Although typically quite lucid in his explanations of his theories, James used words that were so ____ that the students asked him to review yesterday's discussion in its entirety.

- realistic
- obvious
- abstruse
- benevolent
- obscure
- disparate

Question 14

The Renaissance, Dutch masters, Impressionists, and Cubist paintings were all installed in the same museum gallery with what seemed to be no consideration to the arrangement, but closer examination revealed that the ____ was actually arranged in alphabetic order of work title.

- jumble
- littoral
- chromatic
- gallimaufry
- melisma
- diatribe

Question 15

The halcyon days of the new administration belied the president's ____ journey to the White House.

- facile
- tortuous
- anfractuons
- imperial
- dexterous
- felicitous

Question 16

After being defeated in 2007, the Australian Liberal party needed to find a leader who could return them to power; they hope that the current leader, a social conservative who leads the opposition on a number of issues, including stem cell research and carbon

trading, and who wrote a book with the telling title *Battlelines*, may be the man for the job.

- compliant
- circumspect
- diffident
- pugnacious
- milquetoast
- disputatious

Question 17

The bill pushed through by the foreign government was touted as increasing transparency, professional integrity, and independence for the media; in reality, though, the bill was simply a way for the officials to protect their cronyism from the newspapers that had been _____ in their attempts to expose government corruption.

- assiduous
- lackadaisical
- perfunctory
- eschewed
- abjured
- sedulous

Question 18

The preening emperor loved to display sartorial splendor, and regularly gave great attention to the detail of his _____.

- panegyric
- raiment
- fetes
- caparison
- soirees
- oratory

Question 19

Though Marian thought her grandmother's hat was unquestionably _____, the young woman respected her elders enough to make no comment on her grandmother's fashion choices.

- iconoclastic
- imperious
- haughty
- gaudy
- garish
- heretical

The other students in the dining hall quickly learned to avoid any table where Fred was sitting because he constantly interjected _____ remarks into every conversation going on nearby.

- puerile
- crude
- limpid
- inimical
- jejune
- insidious

ANSWERS

Drill 1

1. B, E
2. D, F
3. C, E
4. B, F
5. E, F
6. C, F
7. B, E
8. D, F
9. C, E
10. A, B
11. A, C
12. C, E
13. A, E
14. B, F
15. D, E
16. A, C
17. D, F
18. B, F
19. D, E
20. C, F

Drill 2

1. C, E
2. C, D
3. A, D
4. B, E
5. B, F
6. E, F
7. C, D
8. C, F
9. C, E
10. A, B
11. C, E
12. C, D
13. A, B
14. C, E
15. B, D
16. C, F
17. C, D
18. B, E
19. B, C
20. C, D

Drill 3

1. E, F
2. C, F
3. A, E
4. E, F
5. D, F
6. B, E
7. B, F
8. A, D
9. B, F
10. D, F
11. C, E
12. A, B
13. A, C
14. D, F
15. A, C
16. C, F
17. B, D
18. A, C
19. A, E
20. E, F

Drill 4

1. C, E
2. A, E
3. B, E
4. B, F
5. A, B
6. C, F
7. A, F
8. D, E
9. B, C
10. B, E
11. B, D
12. A, D
13. B, D
14. B, E
15. A, C
16. C, E
17. D, F
18. B, F
19. A, F
20. B, D

Drill 5

1. B, F
2. B, E
3. E, F
4. B, E
5. B, E
6. A, F
7. A, F
8. D, F
9. B, C
10. A, D
11. D, F
12. A, C
13. C, D
14. A, D
15. B, D
16. A, E
17. C, E
18. C, F
19. B, D
20. E, F

Drill 6

1. B, C
2. E, F
3. C, E
4. A, C
5. A, F
6. B, D
7. A, F
8. C, D
9. C, E
10. C, E
11. C, E
12. A, F
13. B, D
14. A, D
15. A, C
16. B, E
17. B, C
18. E, F
19. C, E
20. C, D

Drill 7

1. C, F
2. A, B
3. B, E
4. A, C
5. A, B
6. E, F
7. C, F
8. C, F
9. B, D
10. B, F
11. A, E
12. B, D
13. C, E
14. A, D
15. B, C
16. D, F
17. A, F
18. B, D
19. D, E
20. A, E

Drill 1

1. B and E

The trigger despite indicates that the reefs had not justified the environmentalist's initial fears, so you need a word such as positive or harmless in the blank. Neither caustic nor interminable means positive or harmless, so eliminate answer choices (C) and (E). Neither unfounded, which means groundless, nor plaintive, which means mournful, makes sense in the blank; eliminate choices (A) and (F). Both benign and innocuous can mean harmless, so choices (B) and (E) give you appropriate, equivalent sentences.

2. D and F

Recycle the clue and put enthusiasm in the blank. Both indifference and heedlessness are nearly the opposite of what you are looking for, so eliminate choices (B) and (E). Neither cessation, which means stoppage, nor rhetoric, which is the art of effective or persuasive use of language, make sense in the blank, so eliminate choices (A) and (C). Both fervency and zeal can mean enthusiasm, so answer choices (D) and (F) give you appropriate, equivalent sentences.

3. C and E

The clue innumerable fruitless attempts indicates that Allen lacked the crucial qualification to juggle, so a word that means something like manually coordinated will fit the blank. Both lumbering and awkward are nearly the opposite of what you're looking for, so eliminate choices (B) and (F). Neither sedate, which means calm, nor implicit, which means implied, make sense in the blank, so eliminate choices (A) and (D). Both dexterous and implicit can mean manually coordinated, so choices (C) and (E) give you appropriate, equivalent sentences.

4. B and F

If Alexander's generals broke up his empire at his death, then its cohesion must have been weak or short-lived. Both abiding and protracted are nearly the opposite of what you're looking for, so eliminate choices (A) and (C). Neither redoubled, which means made twice as great, nor renowned, which means famous, make sense in the blank, so eliminate choices (D) and (E). Both precarious and tenuous can mean weak, so choices (B) and (F) give you appropriate, equivalent sentences.

5. E and F

If you're comfortable with the meaning of propitiatory, you can recycle the verb propitiate into the blank; if not, the clue icy stare and aloof demeanor can tell you—like Johann—that the gifts didn't calm her anger. Both exacerbate and aggravate are nearly the opposite of what you're looking for, so eliminate choices (C) and (D). Neither vilify, which means to speak ill of, nor garner, which means to amass or acquire, make sense in the blank, so eliminate choices (A) and (B). Both placate and appease can mean to calm, so choices (E) and (F) give you appropriate, equivalent sentences.

6. C and F

If they believe the benefits of the energy-producing ingredients increase proportionally, the athletes would want to eat more of the energy bars, so you need a word that means something like plentiful. Both scant and measured are nearly the opposite of what you're looking for, so eliminate choices (A) and (E). Neither furtive, which means stealthy, nor solvent, which means capable of paying debts, makes sense in the blank, so eliminate choices (B) and (D). Both copious and profuse can mean plentiful, so choices (C) and (F) give you appropriate, equivalent sentences.

7. B and E

The bill is described as comprehensive and has 249 new regulations on a single industry, so something like full of would make sense in the blank. Both deficient in and unencumbered by are nearly the opposite of what you're looking for, so eliminate choices (C) and (D). Neither elucidated by, which means clarified by, nor exempted from makes sense in the blank, so eliminate choices (A) and (F). Both rife with and replete with mean full of, so choices (B) and (E) give you appropriate, equivalent sentences.

8. D and F

Recycle the clue embarrassing into the blank. Both assuaging and bolstering are nearly the opposite of what you're looking for, so eliminate choices (B) and (E). The impact may be monumental, but that answer choice isn't sufficiently negative, so eliminate choice (C); virulent, on the other hand is too strong, so eliminate choice (A). Both discomfiting and mortifying can mean embarrassing, so choices (D) and (F) give you appropriate, equivalent sentences.

9. C and E

Samuel Huntington's ideas are still passionately debated so they must be described as ideas that people are likely to disagree about. His opinions may well have been pedantic or hegemonic, but those words do not necessarily lead to disagreement. The same goes for zealous, which, in addition, is also used to describe people, rather than their ideas. The correct answers are choices (C) and (E), since polemical means arguing passionately, and divisive means causing a disagreement.

10. A and B

The sentence tells you that there was no plant life in the area before, based on the time trigger word previously. Furthermore, if

humans will be able to live in the area some day, then you know that plant life being described, must be alive and flourishing. This eliminates static, waning, and flagging. Fervent is used to describe human feelings or something that is very hot, so it does not work in this context. Incipient and nascent both mean that the plant life has recently come into being and are the correct answers.

11. A and C

The first part of the sentence implies that Michael talked a lot, but the different-direction trigger word regardless tells you that the word in the blank should be the opposite type of description word. Querulous and eccentric are not related to the context at all, and voluble would imply that he did talk a lot. Disinterested may seem like a plausible answer given that Michael kept to himself, but in that case, a more appropriate word would be uninterested. Disinterested indicates a lack of bias, but the sentence does not deal with a debate or judgment. Choice (A) and (C) are correct.

12. C and E

The snow provides the fresh water so if there isn't much snowfall, the cities will be lacking water. Choices (A), (D), and (F) all have the opposite meaning and proliferation and burgeoning are not really words that could be used to describe run-off either. Paucity and dearth both indicate that something is lacking and are the correct choices.

13. A and E

The girl could always find something else that displeased her which means that she must be a habitual complainer. She may be an impertinent complainer, but there is no evidence that she was rude in the way she complained. The same problem exists with choices (C) and (F). Oblique, which means not straightforward, does not make sense in context, which rules out choice (D). Inveterate and chronic are synonyms for habitual, so choices (A) and (E) are correct.

14. B and F

The different-direction trigger word to focus on here is instead, which tells you that the type of person she is should be different from one who has a secret. Inscrutable is similar in meaning to an enigma behind the celebrated smile, so choice (E) is incorrect. Lisa de Giocondo may well have been dulcet or comely, but there is no supporting evidence for these words in the sentence. You may want to rule out choice (B) because it appears to be a trap since the sentence is about a work of art; however, an artless person is one who does not intend to deceive. A good synonym for it is choice (F), ingenuous.

15. D and E

The sentence contains the trigger word Though, indicating a shift in the meaning of the sentence. In the first part, the futurist conceded that the iPhone was revolutionary, thus the second part must mean that it was old-fashioned. Check the answers. Only antediluvian and superannuated mean old-fashioned. Choices (D) and (E) are the best answers.

16. A and C

Gainsaid means contradicted, so the words that will fill in the blank will roughly mean transparent. Abstruse and cryptic both mean difficult to understand, so eliminate choices (B) and (E). Neither aesthetic, which means concerned with beauty, nor recalcitrant, which means resistant to authority, fits the meaning you need; eliminate choices (D) and (F). Both perspicuous and manifest can mean easily understood, so choices (A) and (C) produce logical sentences with the same meaning.

17. D and F

Hyperbolic means exaggerated. The correct answers will be words that mean something a bit more extreme than quaint and abstracted from cities that also contrast with the imposition of mining equipment. Germane means relevant to, and doesn't fit here; eliminate choice (A). Gentrified refers to an area that was previously owned or occupied by poor people and is transformed by more wealthy people. Although it is relevant to the subject, it is a trap that doesn't fit with the rest of the sentence, so choice (B) should be eliminated. Aplomb (self-confidence) and rancorous (greatly hostile) are similarly irrelevant to this question, so eliminate choices (C) and (E). Bucolic means idyllically pastoral or rural, and quiescent means quiet or restful. Plugging either into the blank produces a sentence that is congruent, making choices (D) and (F) the best answers.

18. B and F

The sentence says that local commercials are a tonic or "cure" for homogeneity or "sameness", so a good word would be quirks or individualities. Check the answers. Both eccentricities and idiosyncrasies mean quirks. The best answers are choices (B) and (F).

19. D and E

The spending, combined with bad investments, left the boxer insolvent, so you need something like excessive for the blank. Both parsimonious and penurious are nearly the opposite of what you're looking for, so eliminate choices (A) and (B). Neither perfidious, which means disloyal, nor pugnacious, which means belligerent, makes sense in the blank, so eliminate choices (C) and (F). Both prodigal and profligate can mean excessive, particularly in reference to spending, so choices (D) and (E) give you appropriate, equivalent sentences.

20. C and F

Since the blank refers to something delivered by a poet or orator and meant to lavish praise, you need something like poem of praise or speech of praise. Three of the choices are the wrong kind of writing: Both an elegy and a jeremiad express lamentation, and a compendium expresses condemnation, so eliminate choices (B), (D), and (E). A compendium is a brief summary, so eliminate choice (A).

Both encomium and panegyric can mean poem or speech of praise, so choices (C) and (F) give you appropriate, equivalent sentences.

1. C and E

What she heard disheartened the band director—and this despite having steeled herself for the worst—so you need a word that means bad-sounding. Both euphonious and harmonious are nearly the opposite of what you're looking for, so eliminate choices (B) and (F). Neither arduous, which means difficult, nor ample, which means sufficient, makes sense in the blank, so eliminate choices (A) and (D). Both cacophonous and discordant can mean bad-sounding, so choices (C) and (E) give you appropriate, equivalent sentences.

2. C and D

All the sentence tells you about Bede is that he earned the epithet venerable, so something like venerated or honored would make sense in the blank. Both defamed and reviled are nearly the opposite of what you're looking for, so eliminate choices (A) and (F). Neither consoled, which means gave comfort to, nor mitigated, which means made less severe, makes sense in the blank, so eliminate choices (B) and (E). Both revered and esteemed can mean honored, so choices (C) and (D) give you appropriate, equivalent sentences.

3. A and D

The sentence contrasts the rules of etiquette with the detailed written regulations regarding play, so you need something like vague or unwritten for the blank. Both express and manifest are nearly the opposite of what you're looking for, so eliminate choices (C) and (F). Be careful about laconic: It means using few words, but not unspoken, so eliminate choice (B). Reclusive, which means withdrawn from society, doesn't make sense in the blank, so eliminate choice (E). Both implicit and tacit can mean unwritten, so choices (A) and (D) give you appropriate, equivalent sentences.

4. B and E

The trigger word but is key in this sentence because it denotes a reversal over time. Since you are told that those who had fought for its ratification were discouraged, the word but tells you they were once encouraged. Therefore, auspicious and promising fit the blank as they tell the same story as encouraged. Bleak and unfavorable tell the opposite story and are not correct. Suspicious means distrustful and ineffectual means useless, and neither word fits the meaning of the blank.

5. E and F

Instead of is a trigger that tells you that the word in the blank must mean the opposite of a selfish need to meddle. Benevolence and magnanimity both mean showing good will toward others, which is the opposite of selfishness. Elegance and refinement are synonyms that mean gracious style, which is not the opposite of selfishness. Gaiety means happiness and viscosity means stickiness, neither of which is the direct opposite of selfishness.

6. E and F

Since he had few former employers who would be laudatory about his past projects, Robert could not provide more than a few references. Both dearth and paucity can mean few, so choices (E) and (F) give you appropriate, equivalent sentences. Both multitude and myriad mean the opposite of what you're looking for, so eliminate choices (A) and (C). Likewise, array and potpourri are synonyms that mean assortment, so eliminate choices (B) and (D).

7. C and D

The trigger while indicates that most of the tasks, which are described as undemanding, differ from the one described in the blank; hence, you need a word like demanding. Both arduous and onerous can mean demanding, so choices (C) and (D) give you appropriate, equivalent sentences. Choices (A) and (F) give you synonymous meanings, but nothing in the sentence supports the description of the tasks as clear.

8. C and F

The blank describes what the politician is doing: she beguilingly greeted a room full of constituents to get their support, so a word like convince would make sense. Both alienate and estrange are nearly the opposite of what you're looking for, so eliminate choices (A) and (E). Neither abase, which means to degrade, nor eviscerate, which means to gut, makes sense in the blank, so eliminate choices (B) and (D). Both inveigle and entice can mean convince, so choices (C) and (F) give you appropriate, equivalent sentences.

9. C and E

The time triggers after and once indicate that the landscape is no longer arid, so you need a word that means something like not dry and lifeless. Both barren and desolate are nearly the opposite of what you're looking for, so eliminate choices (B) and (D). Neither innocuous, which means harmless, nor limpid, which means clear, is supported by the sentence, so eliminate choices (A) and (F). Both verdant and bountiful can mean not dry and lifeless, so choices (C) and (E) give you appropriate, equivalent sentences.

10. A and B

The man's response to visitors was that he shooed them away, so you need a word that means something like not social. Both garrulous and affable are nearly the opposite of what you're looking for, so eliminate choices (E) and (F). Neither sarcastic nor chauvinistic is supported in the sentence, so eliminate choices (C) and (D). Both misanthropic and curmudgeonly can mean not social, so choices (A) and (B) give you appropriate, equivalent sentences.

The time trigger used to be indicates that Eileen is no longer a picky eater, so you need a word that means something like adventurous with food. Both finicky and persnickety are nearly the opposite of what you're looking for, so eliminate choices (B) and (F). Choices (A) and (D) give synonymous meanings, but nothing in the sentence supports the idea that Eileen gained weight. Both epicurean and gourmandizing can mean adventurous with food, so choices (C) and (E) give you appropriate, equivalent sentences.

12. C and D

The blank describes the recesses of the rooms, so recycle the clue dark. Both gloomy and stygian can mean dark, so choices (C) and (D) give you appropriate, equivalent sentences. If you don't know stygian—it's the adjectival form of Styx, the river crossed to get to the Greek afterlife, and so literally means dark as hell—use your POE. Choices (E) and choice (F) are synonyms, but aren't supported by the sentence. The recesses may be empty, but, again, that can't be supported by the sentence; eliminate choice (A). Cacophonous means having a harsh or discordant sound, so choice (B) wouldn't make sense in a room where the agents' ears were attuned to the slightest disturbance.

13. A and B

The text tells you that the man is anxious to avoid a label, so his actions must contrast with the label he is trying to avoid. He wants to present a frugal picture, so he must be saving money. Therefore, the missing word must mean something like reckless spender. Choices (C) and (E) could be attractive if you miss the contrast between the clue and the blank; these words mean stingy person and are opposite of what you need. Choices (D) and (F) are synonyms, but there aren't any clues in the sentence that indicate the man is seeking pleasure. That leaves choices (A) and (B), both of which mean wasteful spender and make them the best answers.

14. C and E

The clue here is that the pirate can't satisfy his craving, so you need a word like insatiable or greedy for the blank; rapacious and voracious give you appropriate, equivalent sentences. Both ebullient and effusive are nearly the opposite of what you're looking for, so eliminate choices (B) and (F). Raffish and showy could describe a pirate, but there's no context to support that pair of synonyms, so eliminate choices (A) and (D).

15. B and D

The clue is that the criminal carried out heinous acts, so the blank describing the criminal must be something like evil. Both enormity and iniquity can mean evil, so choices (B) and (D) give you appropriate, equivalent sentences. Choices (C) and (E) give equivalent meanings, but the sentence doesn't support the characterization of the criminal as clever. Neither pulchritude, which means beauty, nor perfidy, which means disloyalty, makes sense in the blank, so eliminate choices (A) and (F).

16. C and F

You know from the clue that human sacrifices were ubiquitous, so the act was familiar to all the tribes. The text sets up a contrast between the Mayans and the neighboring tribes in terms of their sacrificing. The trigger word while signals that the missing word goes in the opposite direction of the clue, and it must mean making the other tribes uncomfortable. Eliminate choices (B) and (E) because those words are positive. Choice (D), expatiated, means speak about in detail and has nothing to do with the context of the sentence. Despite its topical relevance, choice (A) doesn't contrast with the ubiquity of the sacrifices, nor does the context support the Mayans confining all the other tribes. Although choices (C) and (F) aren't synonyms, they both fit with the given context to appropriately complete the sentence.

17. C and D

The trigger in contrast to indicates that the colorful depictions of castles differ from the stark facades of their surviving ruins, so you need a word like decorated for the blank. Both bedizened and caparisoned can mean decorated, so choices (C) and (D) give you appropriate, equivalent sentences. Choices (A) and (B) would also give equivalent meanings, but nothing in the sentence suggests the castles were weakened. Neither extirpated, which means exterminated, nor fomented, which means incited, makes sense in the sentence, so eliminate choices (E) and (F).

18. B and E

Recycle the clue sanctimonious and self-righteous into the blank. Both ingenuous and unaffected are nearly the opposite of what you're looking for, so eliminate choices (A) and (F). Neither punctilious, which means overly concerned with precise formalities, nor salacious, which means obscene, is supported by any clues in the sentence, so eliminate choices (C) and (D). Both moralistic and sententious can mean sanctimonious and self-righteous, so choices (B) and (E) give you appropriate, equivalent sentences.

19. B and C

The blank refers to the tone of the chair's remarks, which offended people accustomed to being addressed in a more collegial and egalitarian manner. Thus, you need a word that means non-collegial or non-egalitarian; a simple word like bossy works well. Choices (D) and (E) give roughly synonymous meanings, but nothing in the sentence supports the idea that the speech was optimistic. Neither ignominious, which means shameful, nor saturnine, which means gloomy, makes sense in the blank, so eliminate choices (A) and (F). Both imperious and peremptory can mean bossy, so choices (B) and (C) give you appropriate, equivalent sentences.

20. C and D

The trigger is that the comments were meant to do one thing but served only to do another and the respective clues are sophistication and not yet mature. The comments failed to project sophistication and so the blank must be a word that means immature. Choices

(A), (B), (E), and (D) are all words that describe what Hannah may be like, but none have the meaning of immature that is needed to complete this sentence correctly. Choices (C) and (D) are correct.

1. E and F

The clue here is that Plath produced just two volumes. This phrase, in addition to the comparison to the number of volumes her husband produced, tells you that she did not produce many. Remember that before the blank you have the trigger word not, so you need a word that means productive. Choices (A), (B), (C), and (D) are all adjectives that describe what Plath might or might not have been, but they do not fit the given clue. Choices (E) and (F) are correct because they are synonyms of productive.

2. C and F

The clown invokes laughter and enjoyment, so he must represent a happy character. Ace and crackerjack are synonyms that refer to someone with a certain talent, which may be true of the clown, but these answers are not supported by the clues. Artful may sound like an appropriate answer, but, in addition to meaning skilled, it can mean sly or crafty. None of these are the right definitions. Surly has the opposite connotation of happy, so the correct answers are choices (C) and (E), which both mean friendly or pleasant.

3. A and E

Recycle the clue carefully into the blank. Choices (B) and (D) can be eliminated; they give synonymous meanings, but nothing in the sentence supports the idea that the photographer was rushed. Neither subversively, which means rebelliously, nor hysterically, which means characterized by irrationality due to uncontrollable emotion, is supported by the sentence, so eliminate choices (C) and (F). Both meticulously and fastidiously can mean carefully, so choices (A) and (E) give you appropriate, equivalent sentences.

4. E and F

Before the workshop, the writers' comments were general and unhelpful; the time triggers in the sentence tell you that things were different after finishing the editing workshop, so you need a word like specific or helpful in the blank. Three of the choices—cursory, superficial, and amateurish—are nearly the opposite of what you're looking for, so eliminate choices (A), (C), and (D). Derisive, which means scornful, isn't supported by the sentence, so eliminate choice (B). Both critical and constructive can describe comments that are specific and helpful, so choices (E) and (F) give you appropriate, equivalent sentences.

5. D and F

The trigger while indicates that the admirers do the opposite of the others, who disparage it, so something like praise would make sense in the blank. Both defame and underrate are nearly the opposite of what you're looking for, so eliminate choices (A) and (E). Choices (B) and (C) give roughly synonymous meanings, but aren't supported by the sentence. Both commend and extol can mean praise, so choices (D) and (F) give you appropriate, equivalent sentences.

6. B and E

The professor was disheartened because Tom didn't seem to care about his grade, so a word that means without care would make sense in the blank. Both gingerly and delicately are nearly the opposite of what you're looking for, so eliminate choices (A) and (F). Neither timidly, which means fearfully, nor prudently, which means cautiously, is supported by the sentence, so eliminate choices (C) and (D). Both flippantly and thoughtlessly can mean without care, so choices (B) and (E) give you appropriate, equivalent sentences.

7. B and F

The clue here is that the investor's mood seemed incongruous in light of the bad news about the stock market; since incongruous means out of place, you need a word like happy for the blank. Both inconsolable and funereal are nearly the opposite of what you're looking for, so eliminate choices (C) and (E). Neither enervated, which means weakened, nor sardonic, which means mocking and derisive, is supported by the sentence, so eliminate choices (A) and (D). Both sanguine and buoyant can mean happy, so choices (B) and (F) give you appropriate, equivalent sentences.

8. A and D

The blank describes fans who would wait in line for hours to talk to artists and buy toy variants, so a word like devoted would make sense. Choices (B) and (E) give roughly synonymous meanings, but nothing in the sentence supports the idea that the fans smelled bad. Neither hirsute, which means hairy, nor impecunious, which means poor, is supported by the sentence, so eliminate choices (C) and (F). Both staunch and zealous can mean devoted, so choices (A) and (D) give you appropriate, equivalent sentences.

9. B and F

The blank describes the kind of proofreading that would miss errors in spelling, diction, and idiom, so a word like sloppy or hasty would make sense—anything that suggests a lack of attention to detail. Both fastidious and meticulous are nearly the opposite of what you're looking for, so eliminate choices (D) and (E). Neither artless, which means without guile, nor extraneous, which means irrelevant, is supported by the sentence, so eliminate choices (A) and (C). Both cursory and perfunctory can mean inattentive to detail, so choices (B) and (F) give you appropriate, equivalent sentences.

10. D and F

Your word for the blank needs to reflect the idea that Eno is everywhere, so something like common or prevalent would make sense. Choices (B) and (E) give roughly synonymous meanings, but nothing in the sentence supports the idea that Eno is disreputable. Neither omnivorous, which means eating all foods, nor fortuitous, which means accidental, is supported by the sentence, so eliminate choices (A) and (C). Both omnipresent and ubiquitous mean present everywhere—like sodium and divine beings—so choices (D) and

(F) give you appropriate, equivalent sentences.

11. C and E

The blank describes the kind of meanings that don't become clear for years, so you need something like hidden or unclear. Both manifest and lucid are nearly the opposite of what you're looking for, so eliminate choices (B) and (F). Neither banal, which means trite and commonplace, nor nascent, which means newly formed, is supported by the sentence, so eliminate choices (A) and (D). Both oblique and allusive can mean unclear, so choices (C) and (E) give you appropriate, equivalent sentences.

12. A and B

Having committed an expensive error, Whitman might reasonably expect to be criticized or blamed. Both lauded and extolled are nearly the opposite of what you're looking for, so eliminate choices (D) and (F). Neither instigated, which means incited, nor repatriated, which means returned to one's land of citizenship, is supported by the sentence, so eliminate choices (C) and (E). Both censured and excoriated can mean criticized, so choices (A) and (B) give you appropriate, equivalent sentences.

13. A and C

The colon indicates that the purpose will agree with the information in the second part of the sentence, where the young audience is learning advanced vocabulary; a word that means something like teaching would make sense. Both obfuscating and mystifying are nearly the opposite of what you're looking for, so eliminate choices (B) and (F). Neither aggrandizing, which means making larger or more powerful, nor ephemeral, which means short-lived, is supported by the sentence, so eliminate choices (D) and (E). Both didactic and edifying can mean intended to instruct, so choices (A) and (C) give you appropriate, equivalent sentences.

14. D and F

The blank describes comments were startling, despite the author's reputation as anti-social, so something that means anti-social or unfriendly would make sense. Both simpatico and winsome are nearly the opposite of what you're looking for, so eliminate choices (A) and (E). Choices (B) and (C) give synonymous meanings, but nothing in the sentence supports the idea that the author is hard to understand. Both splenetic and churlish can mean unfriendly, so choices (D) and (F) give you appropriate, equivalent sentences.

15. A and C

The blank describes the role played by the kind of evidence that would justify a decision to continue the investigation, so a word that means something like important would make sense. Both negligible and marginal are nearly the opposite of what you're looking for, so eliminate choices (B) and (F). Choices (D) and (E) give roughly synonymous meanings as well, but nothing in the sentence supports the description of the role as dishonest. Both paramount and salient can mean important, so choices (A) and (C) give you appropriate, equivalent sentences.

16. C and F

The blank describes what consumers demonstrate when boycotting companies, so a word like disapproval would make sense in the blank. Both endorsement and ratification are nearly the opposite of what you're looking for, so eliminate choices (A) and (B). Neither debilitation, which means weakening, nor machinations, which means schemes, is supported by the sentence, so eliminate choices (D) and (E). Both censure and disapprobation can mean disapproval, so choices (C) and (F) give you appropriate, equivalent sentences.

17. B and D

The military is using anodyne phrases to gloss reality, so a word that means something like euphemisms or unclear statements. Both elucidation and dysphemisms are nearly the opposite of what you're looking for, so eliminate choices (A) and (F). Neither prevarication, which means untruth, nor hyperbole, which means exaggeration, is supported by the sentence, so eliminate choices (C) and (E). Both periphrasis and circumlocutions can mean unclear statements, so choices (B) and (D) give you appropriate, equivalent sentences.

18. A and C

The semicolon trigger indicates that the two parts of the sentence will agree, so recycle the clue understanding into the blank or use a simple word like knowledge. Both incognizance and nescience are the opposite of what you're looking for, so eliminate choices (B) and (E). Neither somnolence, which means drowsiness, nor belletrism, which means engagement in the genre of literature known as belles-lettres, is supported by the sentence, so eliminate choices (D) and (F). Both discernment and acumen can mean understanding, so choices (A) and (C) give you appropriate, equivalent sentences.

19. A and E

The sentence tells you that animals give predators advanced warning of their danger, so you know the bright colors are warning signs. The while trigger changes the direction of the second part of the sentence, which you can see with the mention of the harmless scarlet kingsnake, but then there's another contrast with the simply mimic phrase. This brings you back to the animals that are unpalatable or dangerous. You can recycle dangerous for the blank. Eliminate choice (B) right away, because if the animals are dangerous, they definitely aren't friendly. Choice (D) might initially look appealing, but it actually means beautiful. While the animals might be brightly-colored, you're looking for something that means dangerous, so you can eliminate that answer. You're left with two sets of synonyms, choices (A) and (E) and choices (C) and (F). The words in the second set, choices (C) and (F), mean edible. If you missed one of the contrast triggers, you might be tempted to go with that pair, but because you have the two different changes of direction, you can eliminate them. That leaves (A) and (E) as the best answers.

The topic of the text is mummification, which deals with drying out the body and preventing decomposition. There is a contrast, indicated by the while trigger, between the Egyptian pharaoh mummies and the Tarim mummies. The text tells you that the Egyptian mummies were intentionally preserved, so you can fill in the blank with something to indicate the Tarim mummies were naturally preserved. Choices (B) and (C) could be tempting, because the mummies were discovered, but that's not what the missing word means. Choice (A) has nothing to do with the context of the sentence, and choice (D) is the opposite of what you're looking for.

1. C and E

To prepare for his speech, Thomas was dutifully rehearsing, your clue that the speech was well spoken. Synonyms for well-spoken are eloquent and articulate, which are your answers. Languid means dull and listless means without energy; both are similar adjectives that Thomas would try to avoid. Extended means long, and you have no clues that the speech should be long. Finally, enduring means everlasting and, while such a speech would be commendable, Thomas is more interested in the well-spoken aspect of his speech.

2. A and E

The Prime Minister was worried that he had lost the support of his party, so he needed to forcefully reverse his controversial statement. You're looking for a word that means take back. Both recanted and disavowed convey taking back a previous statement, and produce equivalent, appropriate sentences. Affirmed and validated are synonyms that mean declared true, which is the opposite of what you're looking for. Overlooked and ignored are close in meaning, but they don't make sense in the given context.

3. B and E

From the clues convenient online access to reading material, it is likely that forecasters would predict a sales decrease. Therefore, you are looking for words that mean decrease. Multiply and appreciate both mean to increase, so you can eliminate choice (A) and choice (F). Prevail means to dominate, which does not match the meaning you need, and assimilate means to integrate and adjust to, which may seem apt but does not fit the context of the blank or retain the meaning of the sentence. Abate and dwindle mean to decrease, and are your best answers that produce equivalent, appropriate answers.

4. B and F

If Natalie was nervous about receiving an unpleasant lecture but her fears were easily relieved, then the policeman must have been the opposite of unpleasant. So you are looking for words that means pleasant or friendly. Exacting and stringent mean meticulously demanding, and so you can eliminate choice (A) and choice (D). Affable and genial can both mean friendly, and are the best answers. Atypical means nonconforming, which does not retain the meaning of the sentence. Sober can mean calm; though the policeman may have also been calm, you're looking for words that mean pleasant or friendly. Furthermore, sober does not have a synonym amongst the other answer choices.

5. A and B

The statisticians certainly hope to win the lottery and the change-direction trigger word even and the clue misguided signal that they are acting inappropriately, despite their knowledge. You want words that mean increase. Mitigate and curtail make a good synonym pair that means to lessen, which is contrary to what you need. Squander is what the statisticians might do with the money after they win it and divulge, meaning to make known, does not make sense in context. Augment and escalate both mean to increase, and so choices (A) and (B) give you appropriate, equivalent sentences.

6. C and F

Since the people in the sentence cannot develop a logical argument, they might be offering an empty, meaningless statement instead to excuse their behavior. The word saying would be appropriate for the blank. Fallacy might seem like a suitable answer, but there aren't any clues in the sentence to prove that the statement is false. Allusion is a reference to something, a query is a question, and a waiver is the relinquishment of something. None of these words have the meaning of saying. Maxim and proverb are both meaningful sayings, and so choices (C) and (F) give you appropriate, equivalent sentences.

7. A and F

Both the description of the ideological gap as insurmountable and the trigger while tell you that the word for the blank needs to mean the opposite of accumulating wealth. Both avarice and cupidity are the opposite of what you're looking for, so eliminate choices (B) and (E). Neither empathy, which means the vicarious experience of another person's feelings, nor parsimony, which means frugality, is supported by the sentence, so eliminate choices (C) and (D). Both largess and philanthropy can refer to generosity with money, so choices (A) and (F) give you appropriate, equivalent sentences.

8. D and E

The critics misjudged the designs, so you know that the word in the blank must mean the opposite of epitome of high fashion. Choices (B) and (F) give roughly synonymous meanings, but nothing in the sentence supports the idea that the designs were expensive. Neither defamatory, which means libelous, nor contrite, which means remorseful, is supported by the sentence, so eliminate choices (A) and (C). Both mundane and insipid can mean uninspired or ordinary, so choices (D) and (E) give you appropriate, equivalent sentences.

9. B and C

Since Brookstone has lost several professional allies, and the blank describes something done against the university's administration, a word that means something like attacks or opposition would make sense. Both approbations and commendations are nearly the opposite of what you're looking for, so eliminate choices (A) and (E). Neither precursors, which means predecessors, nor canons, which means accepted principles or rules, is supported by the sentence, so eliminate choices (D) and (F). Both tirades and diatribes mean angry speeches, so choices (B) and (C) give you appropriate, equivalent sentences.

Since the information given by astrologers can never be conclusively proven or falsified, Sergei can't know whether it's true; thus, a word that means something like trickery or deception would make sense in the blank. Both vindication and authentication are nearly the opposite of what you're looking for, so eliminate choices (C) and (D). Neither censure, which means criticism, nor vexation, which means anger, is supported by the sentence, so eliminate choices (A) and (F). Both chicanery and wile can mean trickery, so choices (B) and (E) give you appropriate, equivalent sentences.

11. B and D

The sentence tells you that the selection of a fresh cause happens every five years, so the blank must refer to a word such as habit or custom. Ambivalence would indicate that the agencies are not sure about taking this action, and callousness indicate a lack of caring. Wariness would indicate that they are hesitant to change the cause. Affectation is tricky because it sounds similar to affection, which might make it sound like a good choice. However, affectation actually means artificiality, which is not the meaning you need. Choices (B) and (D) are both good substitutes for custom and produce equivalent, appropriate sentences.

12. A and D

Using the same-direction trigger and ... just as, you know that the use of high-fructose corn syrup must also be controversial, the clue to the blank. You want a word that means disagreement or debate. Choices (B) and (F) are synonyms that imply agreement in this context, and should be eliminated. Choice (C) means satisfaction and choice (E) means accuracy; neither choice suggests disagreement or debate and should be eliminated. Choices (A) and (D) both mean disagreement and produce equivalent, appropriate sentences.

13. B and D

Following the colon, the regulations are described as prohibitive and receiving widespread support, the clues to the meaning of the blank. So the goal must be to prohibit or reduce such tactics. Correct choices (B) and (D) mean to limit and produce equivalent, appropriate sentences. Rally and muster are synonyms that mean to raise support for, and pirate means to use without authorization. None of these means prohibit or reduce, so eliminate choices (A), (E) and (F). Choice (C) can mean adorn or elaborate, neither of which fits the context of the blank.

14. B and E

The blank is about the judge's personal opinion; the passage provides that the judge found the law morally objectionable (even though the judge could not rule the law unconstitutional). Thus, find two answers that mean morally objectionable. Choices (B) and (E) work well. Choices (A), (C), and (F) provide the opposite meaning. Choice (D), while related to the fact that the judge did not rule the law unconstitutional, does not fit with the blank's description of the judge's personal opinion.

15. A and C

The structure of the sentence and the use of the word even provide that the ancient text, while not entirely impenetrable to experts, was nonetheless quite unclear. Thus, find two answers that mean quite unclear. Choices (A) and (C) work well. Choices (B), (D), and (E) provide the opposite meaning; while the experts may not be as confused as the laypeople, they do struggle with the meaning. Choice (F), despite its resemblance in sound to choice (A), has a completely different meaning.

16. C and E

The time trigger only later tells you that the earlier feudal system differed from the fully-developed version that came later, so the word for the blank needs to mean not fully developed. Both byzantine and labyrinthine are nearly the opposite of what you're looking for, so eliminate choices (B) and (D). Neither refractory, which means stubborn, nor perfidious, which means disloyal, is supported by the sentence, so eliminate choices (A) and (F). Both nascent and inchoate can mean not fully formed, so choices (C) and (E) give you appropriate, equivalent sentences.

17. D and F

The blank describes the kind of lyrics that would create a tension with cheerful, almost bouncy music, so a word that means something like sad would make sense. Both euphoric and sanguine are nearly the opposite of what you're looking for, so eliminate choices (B) and (C). Neither lubricious, which means lewd, nor recondite, which means not widely known, is supported by the sentence, so eliminate choices (A) and (E). Both saturnine and lachrymose mean sad, so choices (D) and (F) give you appropriate, equivalent sentences.

18. B and F

Recycle the clue delicate into the blank. Both ponderous and cumbersome are nearly the opposite of what you're looking for, so eliminate choices (C) and (E). Neither ephemeral, which means short-lived, nor mettlesome, which means courageous, is supported by the sentence, so eliminate choices (A) and (D). Both diaphanous and gossamer can mean delicate, so choices (B) and (F) give you appropriate, equivalent sentences. If you selected choice (A), be sure to distinguish ephemeral from ethereal, which would have been an appropriate answer choice.

19. A and F

Since the fascination with celebrities and the innovations of the electronic age may inspire something to occur, you need a word that means about to happen. Flagging and attenuating mean weakening, so those words go in the opposite direction from the blank. Calumniating means slandering; while the new paparazzi may indeed be engaging in slander, that's not what the blank is talking about. Trending means becoming liquid. and a trend can't do that. Looming and impending both mean about to happen. so those

words are good fits for the blank.

20. B and D

The blank must describe the doctor's friends, so look for the clue that gives information about those friends. The friends quickly jilted him, meaning that they dishonorably abandoned him. Friends who would do that are not very good friends, so you're looking for a word that means not loyal. Squeamish describes someone who becomes uncomfortable easily, usually around things that are unpleasant to the senses (blood, rodents, etc.). While the friends may be uncomfortable in the doctor's presence, that's not why they abandoned him. Orthodox and stodgy describe people who adhere rigidly to convention. These words describe the medical establishment, not the friends. A staunch ally is one who is loyal, so that word means the opposite of the blank. Fickle and inconstant both mean disloyal, and so they are good fits for the blank.

1. B and F

To fill in the blank, you need to identify what the professor did to the exam question. Because he or she reordered the sentences and added distractions, he or she made the problem more confusing and unclear. Muddled and obfuscated are synonyms that mean made obscure or unclear and are therefore the correct choices. Erased and obliterated are also synonyms, but do not describe what the professor did to the question. Interpreted means made clear, which is the opposite of what the professor did. Engendered is a nice vocabulary word but means produced or caused, which has nothing to do with making a previously created problem confusing.

2. B and E

To fill in the blank, you need to find a word that describes the grandmother who is described in the sentence as having the correct answers to life's difficult dilemmas. Therefore, you want to find words that also describe someone who has all the right answers. Sagacity means acuteness of mental discernment, or, more simply, wisdom. Meanwhile, bewilderment and ignorance are words describing someone who does not have all the right answers. Duplicity and guile are both words having to do with deceit and lying and are not traits of the grandmother suggested in the sentence.

3. E and F

The semicolon trigger tells you the two parts of the sentence agree; since the blank is describing the road, you need a word that means twisted. Both abbreviated and fleeting are nearly the opposite of what you're looking for, so eliminate choices (A) and (C). Neither invigorating, which means energizing, nor immense, which means huge, is supported by the sentence, so eliminate choices (B) and (D). Both serpentine and tortuous can mean twisted, so choices (E) and (F) give you appropriate, equivalent sentences.

4. B and E

The blank describes the kind of observation that would surprise people who thought Lucy was unaware, so a word that means something like sharp or observant would make sense—anything that would show that Lucy was aware. Both asinine and obtuse are nearly the opposite of what you're looking for, so eliminate choices (A) and (C). Choices (D) and (F) have roughly synonymous meanings, but an observation that was clear wouldn't have impressed her classmates. Both perceptive and astute can mean observant, so choices (B) and (E) give you appropriate, equivalent sentences.

5. B and E

The clues are that the guests agreed that had the weather NOT been awful; the implication is that it was otherwise perfect. You are looking for a word that means perfect. Eliminate urban, which means metropolitan and has nothing to do with the meaning you need. Eliminate excessive and disproportionate, choices (C) and (D): Though the wedding may have been overdone or out of balance, these are irrelevant to the clues. Finally, eliminate rustic, choice (F), which means having country simplicity. The best answers are divine and idyllic, both of which mean perfect and produce equivalent, appropriate sentences.

6. A and F

The clue is that Shakespeare was only relying on vibrant and colorful individuals, so the blank must be the opposite of vibrant and colorful. You need a word that means ordinary. Eliminate original and extraordinary, synonyms that have the opposite meaning of ordinary. Eliminate imperial, which means regal, and domineering, which means authoritarian; neither one relates to the context of the blank. Choices (A) and (F), pedestrian and mundane, both mean common or ordinary and produce equivalent, appropriate sentences.

7. A and F

The last part of the sentence parallels the middle part. The clue to the blank is the rapid development of numerous related processes, so the missing word must mean rapid development or expansion. Eliminate choice (B) since it is the opposite of what you're looking for. Choices (C), (D), and (E) seem applicable, but none of these choices stays in the scope of the meaning you need in the blank. Although the daguerreotype was the oldest photographic process, there's no context for this in the blank and you can eliminate those three choices. That leaves correct choices (A) and (F), both of which can mean rapid growth and produce equivalent, appropriate sentences.

8. D and F

You know that the athlete used to be well-respected because of his work with anti-drug programs. The contrast is that he was working with anti-drug programs while using steroids for years, so a good word for the blank would be hypocritical or dishonest. Choices (C) and (E) can be eliminated because they are both positive and mean optimistic, and choice (A) does not mean dishonest and is also incorrect. Choice (B) means related to a crime, and does not necessarily mean dishonest. Choices (D) and (F) are the best answers because they both mean deceitful and produce equivalent, appropriate sentences.

9. B and C

The clue walked quietly instead of throwing rocks indicates the leader must have asked the protestors to stop the violence. Eliminate choices (D) and (E) because they both convey a sense of support or approval and are opposite of what you need in the blank. Choice (F) also doesn't work for a similar reason; manifest means demonstrate. Choice (A) means soothe and does not apply in this context. Choices (B) and (C) are synonyms that mean to avoid or give up and produce equivalent, appropriate sentences.

The manufacturers' goal is to make certain items dedicated collectibles, so they would do something to make them more rare or special. Choices (E) and (F) are synonyms that mean activate, but the blank refers to the trucks themselves and so you can eliminate these choices. Choice (C) can be eliminated because it means examine and doesn't match the needed meaning. Choice (B) is also irrelevant to the context of the blank. That leaves choices (A) and (D), both of which mean to make more rare and produce equivalent, appropriate sentences.

11. D and F

The important clues in this sentence are the words cloudy and semi-transparent, both of which describe the inner workings of the jellyfish. Choice (A) could be tempting because a jellyfish tentacle could definitely be caustic, but there's no context for it. Eliminate it. You can eliminate choice (E) for the same reason. It seems logical, but isn't actually supported by the text. Choice (C) is connected to the sentence because jellyfish are natatory creatures, but the blank is specifically describing the appearance of tentacles, not the jellyfish as a whole. Choice (B) has nothing to do with the sentence. Choices (D) and (F) both mean loose, flowing, or see-through which is what you're looking for.

12. A and C

The sentence tells you that the Jedi were a powerful peace-keeping force, but there's a contrast indicated by the but and the time trigger before the Clone Wars. That lets you know that something is going to happen that will challenge the Jedi's status. The sentence also tells you that every clone trooper was reprogrammed to assassinate his Jedi master. This lets you know that there was a massive attack against the Jedi. So you could fill in the missing word with something like serious injury or really bad experience. You can eliminate choices (B) and (F) because those are going in the wrong direction. They only connect with the powerful Jedi clue, not taking into account the contrast triggers. Choices (D) and (E) have nothing to do with the sentence, so you can eliminate them. That leaves (A) and (C), both of which mean completely destroy.

13. C and D

The sentence tells you that the studios have a penchant for hiring A-list movie stars. Then it tells you those studios are rethinking that strategy, so you know the actors they're looking for now are not A-list. This is further supported with the clues that tell you the economy is not suited to celebrities who get paid \$15 to \$20 million, but to another kind of actor who commands far less per picture. So put something in the blank like unknown or new. You can eliminate choices (A) and (B) because those two answers would describe the A-list celebrities. Choice (E) also fits more with the A-listers because they're the ones who would be expensive. Choice (F) doesn't fit with anything in the sentence. That leaves choices (C) and (D), both of which mean new or just starting out, which is what you're looking for.

14. A and D

You need a word for the blank that means that Joseph was the model of composure. Both quintessence and epitome would mean he is a perfect embodiment of composure, so choices (A) and (D) produce equivalent sentences that make sense. Bane would mean he somehow annoys composure, and is incorrect. Rector would mean Joseph is the priest or academic leader of composure, and antithesis would mean he proves the opposite of composure; eliminate choices (C) and (E). Regent would mean he is the king ruling over composure, so eliminate choice (F).

15. B and D

Since the President could not tolerate dissent from his views, you need a word that means his cabinet members would always agree with him. Pundits and authoritarians would offer their own strong opinions, so eliminate choices (A) and (F). Cynics would act pessimistically, so eliminate choice (C). Partisans would be biased, but not necessarily all in the same direction as the President, so eliminate choice (E). Sycophants and toadies in choices (B) and (D) are synonyms indicating that the members are flatterers or yes-men, and produce equivalent statements.

16. A and F

The clue to the blank is encomium, which means a speech of high praise. Since the poet is young and afraid that her career reached a premature point, the word in the blank must mean peak. Apogee and zenith both mean highest point, so choices (A) and (F) validly complete the sentence. An auspice means good sign, so eliminate choice (B). Coda means a concluding section and does not fit this context, so eliminate choice (C). Nadir and perigee both mean lowest point and are the opposite of what you need, so eliminate choices (D) and (E).

17. C and E

The logic is hard to follow, so you need a word for the blank that means confusing or convoluted. Both labyrinthine and byzantine mean twisting and turning like a maze, so keep choices (C) and (E). Rhetorical means using a strong, formal writing style, so eliminate choice (A). Libertine and unscrupulous are roughly synonymous, and both mean having lax moral standards, so eliminate choices (B) and (D). Decorous means dignified or proper, so eliminate choice (F).

18. C and F

The CEO took money, so you need a word for the blank that means the board members, shareholders, and customers punished him. Cachinnated means laughed at, so eliminate choice (A). Blandished means flattered, so eliminate choice (B). Upbraided means censured, and so does lambasted, so keep choices (C) and (F). Simpered means smiled, so eliminate choice (D). Caviled means to find fault with unnecessarily, but since the CEO embezzled, this can't work. Get rid of choice (E).

19. B and D

Since punctilious means having very strong attention to detail, especially with etiquette, this is a good thing to describe service. The word while tells you that you need something in the other direction for cuisine, so you need a word that means the food is not too great. Obsequious means flattering, eliminate choice (A). Both quotidian and pedestrian mean commonplace or boring, so keep choices (B) and (D). Distasteful could work, because it could mean unpleasant tasting, but there is no synonym for this word in the choices, and therefore no way to make the sentence equivalent with another one of the choices. Eliminate choice (C). Gustatory means having to do with the sense of taste. This is too broad, so eliminate choice (E). Pedantic is a synonym for punctilious, but we need the opposite, so eliminate choice (F).

20. E and F

Recycle the clue angry response into the blank. Three of your choices—laudation, panegyric, and approbation—are nearly the opposite of what you're looking for, so eliminate choices (A), (C), and (D). A dictum is a formal or authoritative statement; that's not supported by the sentence, so eliminate choice (B). Both invective and vituperation can mean a speech of anger, so choices (E) and (F) give you appropriate, equivalent sentences.

1. B and C

To describe a con artist who left his victims pleased to be victimized, you'd need a word that means something like skillful or tricky. Both *maladroit* and *unskillful* are nearly the opposite of what you're looking for, so eliminate choices (D) and (F). Neither *innocuous*, which means harmless, nor *discrete*, which means distinct, is supported by the sentence, so eliminate choices (A) and (E). Both *crafty* and *cunning* can mean tricky, so choices (B) and (C) give you appropriate, equivalent sentences. If you were tempted by choice (E) because a good con artist would be able to keep a secret, be sure to distinguish *discrete* from *discreet*.

2. E and F

Given the clue most people already know, you know that the way the Secret Service employees are described in the first part of the sentence—in this case *sharp-eyed*—is the same as the way they are described in the second part. Thus, *vigilant* and *mindful* are appropriate for the blank. *Robust* and *potent* are a synonym pair which means strong, which is not supported by the clue, although they may indeed be strong people. They may also be vulnerable in some ways, but this choice would be the opposite of the intended meaning. The same applies for *weary*, which means tired.

3. C and E

The clue in this sentence is filled the air with tension. Both *ambience* and *atmosphere* refer to the environment of a place or situation. All of the wrong answer choices are words that may be associated with a gala, but they do not fit this clue. Choice (B) may seem close, but the rest of the sentence does not tell you what the party-goers were discussing. Choice (E) may also seem like a good fit, but again, the sentence does not tell you how people were acting. Choice (A) would refer to decorations and choice (F) would refer to an activity.

4. A and C

The sentence suggests that it is unfair to tax the middle class unless the upper class is taxed as well. *Sporadic* means occurring at random times, *subtle* means barely noticeable, *dignified* means expressing worthiness or honor, and *pardonable* means forgivable. None of these fit the idea of unfair. Choices (A) and (C) come closest to unfair or unable to be justified.

5. A and F

Since ghosts are described as unseen by the majority, it must be difficult to provide visible or definite proof. *Indisputable* and *demonstrable* both convey the meaning you want, and produce equivalent, appropriate sentences. Choice (D) means important. Choice (B) means intimidating and choice (C) means mysterious. *Skeptical* may be a good word to describe those who don't see the ghosts, but it can't describe the proof.

6. B and D

The sentence tells us that the politician claimed that he did not seek to enrich himself. However, the trigger word *but* indicates that the blank will have the opposite meaning: He did attempt to enrich himself. Choices (B) and (D) work in this context. Choices (A) and (E) go in the wrong direction, as they describe what the politician claimed, and choices (C) and (F) have no relationship to the blank.

7. A and F

The clues to the blank are that it was once unspoiled before the calamitous event, which indicates that it is now damaged, the word you are looking for. Choices (A) and (F) can be used to describe physical destruction and are the best answers. Choices (C), (D), and (E), may refer to the people who live near the seascape, but the blank is only about the seascape and there are no clues about its inhabitants. Choice (B) does not provide a good substitute for *destroyed* or *spoiled*.

8. C and D

The blank is about the first steps taken as part of the strategy of organization. The clues indicate that these steps were among many required steps and were therefore undertaken first and immediately. Thus, they were the most immediate of the required steps. Choices (C) and (D) indicate the immediacy and importance of the steps, and are correct. Choice (A) does not reflect the clue, and choice (B) is the opposite of the word you need and incorrect. There is no information in the sentence to support the remaining choices.

9. C and E

Someone worried about having to analyze an esoteric poem would be delighted to get one that was clear or easily understood, so something like clarity would make sense in the blank. Both *ambiguity* and *opacity* are nearly the opposite of what you're looking for, so eliminate choices (B) and (F). Neither *cadency*, which means rhythm, nor *melancholy*, which means sadness, is supported by the sentence, so eliminate choices (A) and (D). Both *cogency* and *lucidity* can mean clarity, so choices (C) and (E) give you appropriate, equivalent sentences.

10. C and E

A story about Einstein not uttering a sentence in five years would emphasize his image as a quiet scholar. Both *loquacious* and *garrulous* are nearly the opposite of what you're looking for, so eliminate choices (A) and (F). Neither *consummate*, which means perfect, nor *judicious*, which means showing good judgment, is supported by the sentence, so eliminate choices (B) and (D). Both

11. C and E

Since Tess was worried about the pesticides' noxious effects, a word like small or minimal would make sense in the blank. Both capacious and profuse are nearly the opposite of what you're looking for, so eliminate choices (A) and (F). Choices (B) and (D) give equivalent meanings as well, but lasting effects are what Tess is trying to avoid. Both nominal and negligible can mean small, so choices (C) and (E) give you appropriate, equivalent sentences.

12. A and F

The trigger word despite tells you that the first part of the sentence contrasts the second part. So, the blank will have a word that means the opposite of the clues lack of education and obtuse, such as keenly smart. Perspicacious and insightful mean observant or perceptive; these are the best choices. Jejune means immature and vapid means dull, but neither is the opposite of obtuse. Pragmatic means practical and expedient means appropriate; both words could describe good advice, but don't follow from the clue in this sentence.

13. B and D

Emily has a changing career, so she can't guarantee a fixed paycheck. Therefore, her husband must accumulate overtime work from his supervisors. You're looking for a word that means accumulate or ask for. Rebuke means to reprimand, so eliminate it. Eschew and relinquish are synonyms that mean give up, which is the opposite of accumulate. Disseminate means scatter, and does not mean accumulate. Amass and garner can both mean gather and accumulate, and produce equivalent, appropriate sentences.

14. A and D

To fill in the blank, you need to determine what these applications are doing to productivity now. The trigger word however signals that the applications were detractors from productivity, but now have the opposite effect, such as to help. Bolster means to add support or improve and ameliorate means to make better, both of which are the opposite of detract and produce equivalent, appropriate sentences. Vilipend and depreciate both mean to reduce the value of and are the opposite meaning of what you want. Engender means to cause to happen and supplant means to replace; neither word works with the clue or in the context of the blank.

15. A and C

The missing word must be consistent with the clues no new ideas and containing nothing but overt drivel. Lax and amorphous both mean without precision or structure; they're consistent with the end of the sentence, but not with this clue. Natty means neat and tidy, usually in reference to clothing, and does not reflect the clue. Labyrinthine means unnecessarily complicated, but the problem with the poetry is lack of freshness. Platitudinous and jejune both mean trite or uninteresting and produces equivalent, appropriate sentences.

16. B and E

The clue is that Gatsby grows progressively more flagrant in his spending and his lifestyle, so the word in the blank must mean something like inclined to spend money unwisely. Ignominy means shame and volubility means talkativeness, but nothing in the sentence indicates that he feels shame or talks incessantly. Repute and stature mean fame; though Gatsby is a famous character, the blank does not refer to his fame. Dissipation and profligacy can both mean inclined to wastefulness, and produce equivalent, appropriate sentences.

17. B and C

The word in the blank must agree with animated, so anything that means gave life to will work—feel free to recycle animated. Both obliterated and extirpated are nearly the opposite of what you're looking for, so eliminate choices (A) and (F). Neither paralleled, which means was similar to, nor exemplified, which means were examples of, is supported by the sentence, so eliminate choices (D) and (E). Both fomented and galvanized can mean inspired, so choices (B) and (C) give you appropriate, equivalent sentences.

18. E and F

A good editor is interested in distinguishing the best offerings from the worst in an efficient manner, so your word for the blank needs to mean the same thing as distinguish. Both consolidate and integrate are nearly the opposite of what you're looking for, so eliminate choices (A) and (B). Neither finagle, which means to obtain by dishonest or indirect means, nor intimate, which—as a verb—means to insinuate, is supported by the sentence, so eliminate choices (C) and (D). Both winnow and sift can mean separate, so choices (E) and (F) give you appropriate, equivalent sentences.

19. C and E

Brand believes that the distinction obscures a more relevant question, so the word in the blank must mean something consistent with not relevant. Baleful means dangerous, and feckless means incompetent or irresponsible, neither of which are close to not relevant. Critical and cardinal both mean important, so those words are the opposite of what you're looking for. The correct answers here rely on secondary definitions of the words nice and minute. Both of these words can be used to mean so small as to be insignificant.

20. C and D

The word in the blank must be a characteristic of something written in jargon that makes the writing difficult to understand for the average person. Risible means laughably absurd, which is sometimes, but not always a characteristic of jargon writing. Vapid means

boring, which might also sometimes be true of this type of writing, but this word has the connotation of lacking in substance, which political theory usually is not. Uncanny and occult mean strange. While an unfamiliar writing style might indeed seem strange to the general public, these words have a supernatural connotation, which would not be a good fit for a description of political theory. Muddled and abstruse both mean confusing, which would be characteristics that would describe jargony writing from the perspective of the general public.

1. C and F

The clue is that she has been sick for three days and that she is unable to get up, so the missing word means tiredness or exhaustion. Choice (A) is the opposite of what you're looking for, and choice (B) is irrelevant to the context of the blank; both choices can be eliminated. Choices (D) and (E) could be feelings following recovery from the flu, but do not mean exhaustion. Correct choices (C) and (F), both of which mean lacking energy, produce equivalent, appropriate statements.

2. A and B

Jake would be scared by the poisonous snake. You can eliminate choices (C) and (E) because they are positive words. Choices (D) and (F) do not relate to being scared, and can be eliminated. Choices (A) and (B) are correct because both mean worried or scared.

3. B and E

The clue to the blank is passionately insistent of her assertions, signifying that a similar tone helped her team prevail. Recycle the clue and look for words that mean passionately insistent. Choices (A), (D), and (F) indicate that she would have an insecure, impaired or unsure tone, and can be eliminated. Choice (C) is incorrect because there is no clue that she had an odd tone. Correct choices (B) and (E) both mean unshakably determined and produce equivalent, appropriate sentences.

4. A and C

The clue clear and ongoing mismanagement of the city kennel indicates that the mayor would have negative feelings of disapproval. Choices (B), (D), and (E) are positive words that do not complement the clue and should be eliminated. Choice (F) means lack of energy and does not match the meaning you want. Only correct choices (A) and (C) mean disapproval and produce equivalent, appropriate sentences.

5. A and B

The employee's confident smile is hiding confusion, so something that means confused would make sense in the blank. Both placated and conciliated are nearly the opposite of what you're looking for, so eliminate choices (C) and (E). Neither vilified, which means defamed, nor belabored, which means excessively insisted upon, is supported by the sentence, so eliminate choices (D) and (F). Both perturbed and discomposed can mean confused, so choices (A) and (B) give you appropriate, equivalent sentences.

6. E and F

Students who are more attuned philosophical debate would find math and science to be difficult or demanding. Both facile and elementary are nearly the opposite of what you're looking for, so eliminate choices (A) and (D). Neither stupefying, which means perplexing, nor meticulous, which means attentive to detail, is supported by the sentence, so eliminate choices (B) and (C). Both exacting and onerous can mean demanding, so choices (E) and (F) give you appropriate, equivalent sentences.

7. C and F

Although the fact that the ballerina didn't achieve a coveted title might suggest she wasn't a good dancer, the change-direction trigger—at least in the opinion of the general public—indicates that the word in the blank needs to mean something like skillful. Both fulsome and noisome are nearly the opposite of what you're looking for, so eliminate choices (D) and (E). Neither perfunctory, which means careless, nor evanescent, which means fleeting, is supported by the sentence, so eliminate choices (A) and (B). Both consummate and virtuoso can mean extremely skilled, so choices (C) and (F) give you appropriate, equivalent sentences.

8. C and F

The blank is about the review committee's opinion of the candidate's thesis, and the trigger word but indicates that the committee holds the opposite view of the candidate's view. The candidate is confident that the thesis is valid, so the blank means not confident. Correct choices (C) and (F) mean doubtful, and produce equivalent, appropriate sentences. Choices (A) and (E) represent the candidate's view, not the committee's view. Choice (B) means soothed, not doubtful. Choice (D) means annoyed and goes beyond the context of the blank and is not supported.

9. B and D

The blank is about the effect of the letters on the historian's claims. The clue is the historian must reconsider his life's work, so the blank means disproves. Choices (B) and (D) mean makes false and produce equivalent, appropriate sentences. Choices (C) and (F) both have the opposite meaning of disproves, and can be eliminated. Choices (A) and (E) also do not mean disprove and are incorrect.

10. B and F

The blank is about what playwrights should avoid according to the critic, and the clue word trite signals the blank must mean ordinary. If you do not know the word trite, you nevertheless know that the blank must be negative from the phrase could not sit through. Correct choices (B) and (F) mean dull and ordinary, and produce equivalent, appropriate sentences. Choices (C) and (E) are positive, and can be eliminated. Choice (A) means in good judgment and (D) means conveniently practical, and neither choice means ordinary.

The first of two trigger words, hardly, tells you that the outcome of war is not favorable, the clue word. The other trigger is even, you would expect a good outcome for the victors, but this is not the case here and so the nature of war must be very bad. In choice (F), hegemony relates to war but the clue does not support a word that means domination. Choice (D) means strict or stern, but is also not a match for the clue. Choice (C) refers to pompous use of language, and choice (B) means a public display or discourse. Both should be eliminated. The correct answers, choices (A) and (E), mean evil or baseness.

12. B and D

The behavior being described is used to disparage the movement, so it must be inappropriate behavior. Reticent means reserved or shy, so choice (C) is incorrect. Garrulous means talkative and cogent means convincing, but there are no clues to support these choices. Capricious is often used with a negative connotation and means impulsive or unpredictable. Debauched and profligate both mean disregarding social or moral correctness, which makes them the two best answers that produce equivalent, appropriate sentences.

13. C and E

The trigger word and clue Although typically quite lucid in his explanations signals that his explanation in yesterday's discussion was not very clear. So, you need words that mean unclear or hard to understand. Realistic means reasonable and benevolent means kind-hearted. The word obvious has the opposite meaning of the word you need. Only correct answers abstruse and obscure, both of which mean hard to grasp, produce appropriate, equivalent sentences.

14. A and D

The clue is that first the paintings were installed with no consideration to the arrangement and then they were actually arranged in alphabetical order. The blank comes after the trigger word but and agrees with the first description. So, the missing word must mean something like disorganized grouping. Choices (C) and (E) are similar in meaning, but do not pertain to a disorganized group; they can be eliminated. The paintings do not have anything to do with water or the beach, so you can eliminate choice (B). Choice (F) is also irrelevant to the meaning you need. Choices (A) and (D) fit within the context of the sentence and both refer to a random grouping of items.

15. B and C

The word belied indicates a contrast between the current state of the administration, halcyon days, and the president's journey to the White House. Therefore, the missing words must mean the opposite of peaceful or calm; you need a word such as rough or chaotic. Eliminate choice (F), because that word agrees with halcyon. Choices (A) and (E) both convey done easily with skill, and can be eliminated. There is also no context to support a domineering journey, and thus choice (D) is incorrect. That leaves choices (B) and (C), both of which mean twisted or not smooth and produce equivalent, appropriate sentences.

16. D and F

The blank describes a politician who leads the opposition, and whose martially-themed book title is said to be telling, so a word that means something like argumentative or belligerent would make sense. Both compliant and diffident are nearly the opposite of what you're looking for, so eliminate choices (A) and (C). Neither circumspect, which means cautious, nor milquetoast, which means timid, is supported by the sentence, so eliminate choices (B) and (E). Both pugnacious and disputatious can mean argumentative, so choices (D) and (F) give you appropriate, equivalent sentences.

17. A and F

The blank describes the newspapers' attempts to expose government corruption; since the sentence suggests that the threat posed by the papers inspired the new law, a word that means something like effective, thorough, or hard-working would make sense. Both lackadaisical and perfunctory are nearly the opposite of what you're looking for, so eliminate choices (B) and (C). Choices (D) and (E) give roughly synonymous meanings, but aren't supported by the sentence. Both assiduous and sedulous can mean hard-working, so choices (A) and (F) give you appropriate, equivalent sentences.

18. B and D

The clue word sartorial means relating to tailoring or clothing, so the word in the blank must mean clothing. Panegyric and oratory both mean speech, so eliminate choices (A) and (E). Raiment and caparison both mean clothing, making choices (B) and (D) correct. Fetes and soirees are both types of parties, so eliminate choices (C) and (E).

19. D and E

Marian does not comment on her grandmother's hat out of respect, which means she dislikes the hat. You need a word that means ugly or in poor taste. Iconoclastic and heretical both mean going against established beliefs. This is too strong and does not describe a hat, so eliminate choices (A) and (F). Imperious and haughty both mean arrogant, so eliminate choices (B) and (C). Gaudy and garish both mean showy and in poor taste, and can be used to describe clothing. Choices (D) and (E) are both correct.

20. A and E

The other students did not sit at Fred's table because they did not like the remarks he made. The word in the blank must be negative. Puerile and jejune both mean childish and immature, so choices (A) and (E) are correct. Crude means lacking tact, which fits but there is no synonym for crude among the options; eliminate choice (B). Limpid is positive and means clear, so eliminate choice (C). Inimical means hostile and insidious means stealthy or treacherous, but neither word has a synonym among the options. Eliminate choices (D) and (F).



The Math Section



Plugging In & PITA

PLUGGING IN

Math on the GRE can be quite simple. A question may give you the price of an item and the amount of money to be used, and then ask you to figure out how much change should be given. What makes it difficult, however, is that the price will be given as x cents and the amount to be spent as y dollars. In other words, the numbers will be expressed as abstract symbols, a.k.a. algebra; x dollars is an algebraic concept. It is far more difficult to think about and to manipulate x dollars (What do you do with the decimal?) than the actual quantity of \$10. Anytime a symbol appears on the test, it can be replaced by a number. When you do this, what was abstract and fuzzy instantly becomes concrete and easy to work with.

Example:

Eleven years ago, Lauren was half as old as Mike will be in 4 years. If Mike is m years old now, how old is Lauren now in terms of m ?

- $4m - 11$
- $\frac{1}{2}(m + 4) + 11$
- $\frac{1}{2}(m - 11)$
- $4m + \frac{11}{2}$
- $2m - 7$

No one has ever heard of someone being m years old. To turn this from an abstract problem of algebra back into a simple problem of arithmetic, replace the variable with an actual number. In this case, try 10. The question asks you to find out how old Lauren is now. If you set Mike's age to 10, it's not too difficult to figure out how old he will be in four years, and then to figure out that Lauren was half as old as that, eleven years ago. If Mike is 10, Lauren is now 18. This is what you were asked to find; therefore, 18 is your Target Number. In the answer choices, when you replace all m 's with 10, the correct answer should equal 18.

The answers now look like this.

- $4(10) - 11 = 29$
- $\frac{1}{2}(10 + 4) + 11 = 18$
- $\frac{1}{2}(10 - 11) = -\frac{1}{2}$
- $4(10) + \frac{11}{2} = 45.5$
- $2(10) - 7 = 13$

Only one of them is equal to 18. That is the correct answer. This technique is called **Plugging In**.

When you see variables in the answer choices, Plug In.

Once you have recognized this opportunity, you can set up your scratch paper.

It should look like this.

A	29	$M = 10$	$M + 4 = 14$
B ✓	$\frac{1}{2}(10 + 9) + 11 = 18$	18	$L + 11 = 7$
C	$\frac{1}{2}(10 - 11) = -\frac{1}{2}$		$L_{now} = 18$
D	$40 + 5.5$		
E	13		

(Click [here](#) to view a larger image.)

Here are some elements of this set-up to note.

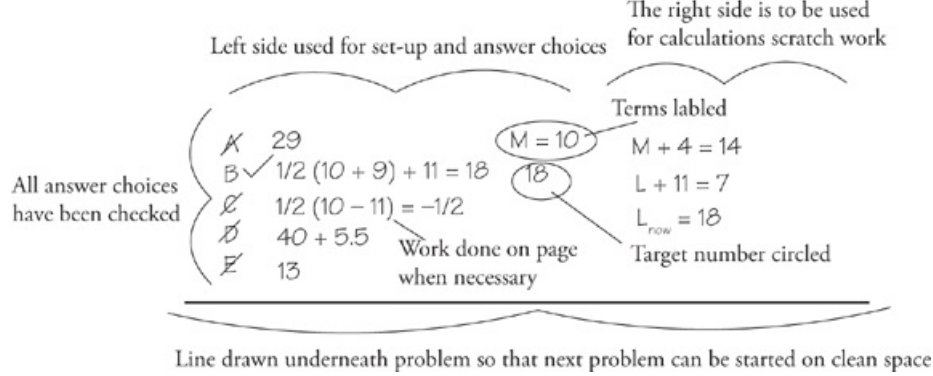

(Click [here](#) to view a larger image.)

When you are Plugging In for a multiple-choice question, you must have your terms labeled and a target number circled. This all happens on your scratch paper. The minute you see variables, write down the answer choices and Plug In.

Try to plug in nice happy numbers that will make your life easier. Avoid Plugging In 1 or 0, not because they are wrong, but only because they may lead to multiple correct answers. If this happens, it's not a big deal. Just change your Plug In number, and check the remaining answer choices.

Plugging In is equally effective on Quantitative Comparisons. In this case, your response should be just as automatic. When that problem pops up, the minute you see that it is Quant Comp and it includes variables, make your set-up. You do this even before you have read and understood the problem. It is an automatic response. See variables, make set-up.

Example:

Wendy purchased n napkins and Juan purchased 2 fewer than half as many napkins as Wendy.

<u>Quantity A</u>	<u>Quantity B</u>
The number of napkins Juan purchased	$\frac{n - 4}{2}$

- Quantity A is greater.
- Quantity B is greater.
- The two quantities are equal.
- The relationship cannot be determined from the information given.

Before you have even read the problem your hand should be moving. Your set-up should look like this.

$$\begin{array}{c}
 \underline{A} \quad \underline{A} \quad \underline{B} \quad \underline{C} \quad \underline{D} \quad \underline{B} \\
 n = \\
 n = \\
 n =
 \end{array}$$

Now plug in a number for the variable, n , and start working the problem.

Your scratch paper will look like this.

$$\begin{array}{c}
 \underline{A} \quad \underline{A} \quad \underline{B} \quad \underline{C} \quad \underline{D} \quad \underline{B} \\
 3 \quad n = 10 \quad 3 \quad \text{half Wendy} = 5 \quad 2 \overline{) 196} \\
 -2 \quad n = 0 \quad -2 \quad 200 - 4 = 196 \quad 16 \\
 98 \quad n = 200 \quad 98 \quad \text{half Wendy} = \cancel{100} - 4
 \end{array}$$

Here are some things to note.

$\frac{A}{3}$	A B C D	$\frac{B}{3}$	half wendy = 5	$2 \overline{) 196}$
-2	$n = 10$	-2	$200 - 4 = 196$	16
98	$n = 200$	98	half wendy = 100 - 4	

On a regular Plugging In problem, use numbers that are easy to work with and calculate. On Quant Comp you must always Plug In more than once. Your first Plug In will be something simple, like 2 or 10. Plug in something nice and easy and then eliminate. If B is bigger, eliminate choices (A) and (C). If they are both the same, eliminate choices (A) and (B). Remember that choice (A) means that Quantity A is always larger, no matter what numbers you plug in for the variables. That means that you have to plug in all kinds of weird stuff to make sure that Quantity A always stays larger. For your second and third Plug In, look for numbers that will generate a different answer. If after your first Plug In you are left with choices (B) and (D), try to prove choice (B) wrong. If you can plug in something that makes Quantity B smaller than Quantity A, then you can eliminate and the answer is choice (D). If you can't, then the answer is choice (B). In other words, when Plugging In on Quant Comp, you are trying to find out whether choice (D)—which really means that neither (A), (B), nor (C) is always correct—is the correct answer. If you can't prove choice (D), then the remaining answer choice is the correct answer. You prove choice (D) by Plugging In different types of numbers and eliminating answer choices as you go. These include Zero, One, Negative numbers, Extremely large numbers, and Fractions. ZONEF is a mental checklist to help you remember what to plug in. If you continue to get choices (A), (B), or (C)—after plugging in everything listed in ZONEF—then that's your answer.

PITA (PLUGGING IN THE ANSWERS)

ETS has given you the answers, which makes the test easier. On a multiple-choice test, one of those answer choices has to be correct; therefore, you can use the answer choices to solve the problem.

Example:

Vicken, Roger, and Adam went to buy a \$90 radio. If Roger agrees to pay twice as much as Adam, and Vicken agrees to pay three times as much as Adam, how much must Roger pay?

- 10
- 20
- 30
- 45
- 65

One of those answer choices must be the correct one. Pick the one in the middle, assume that it is correct, and use that number to work the rest of the problem in bite-sized pieces. The question asks you how much Roger must pay, so label the answer choices "Roger." This is your first column. For every additional step in the problem, make and label an additional column on your scratch paper.

It should look like this:

~~A~~ 29

B $1/2(10 + 9) + 11 = 18$

~~C~~ $1/2(10 - 11) = -1/2$

~~D~~ $40 + 5.5$

~~E~~ 13

M = 10

18

M + 4 = 14

L + 11 = 7

L_{now} = 18

A	A <input checked="" type="radio"/> B <input type="radio"/> C <input type="radio"/> D	B			
3	n = 10	3	half Wendy = 5	200 - 4 = 196	$2 \overline{) 196}$ 16
-2	n = 0	-2	half Wendy = 100 - 4		
98	n = 200	98			

Roger	Adam	Vicken	Total		
10					
20				30	
<input checked="" type="radio"/> 30	15	45	90	15	
45				45	
65				90	

(Click [here](#) to view a larger image.)

You've set up a small spreadsheet using the steps of the problem as your column headings. Once you have made your set-up, the thinking is done for you. All you have to do is fill it in until you come up with an answer choice that works. In this case, according to the question, if Roger pays \$30, Adam will pay half that, or \$15. Vicken pays three times the amount that Adam does, or \$45. The three together pay \$90. The radio costs \$90, so it works, and you're done. Only one answer choice will work; therefore, when you find it, you are done, and you don't have to check the others.

The only tricky thing about this technique is recognizing the opportunity. If the question asks, "How much," "How many," or "What is the value of," Plug In The Answers. If you have specific numbers in the answer choices, and you find yourself oddly compelled to make a formula, Plug In The Answers. Once you recognize the opportunity, get your hand moving and write down the answer choices on the left side of your scratch paper. This is your first column; label it. At this point, you are already halfway into the problem. No time spent thinking; no time spent wondering how to go about solving it. Before you even fully understand the problem, you are already halfway to the answer.

STRATEGY SUMMARY

Once you spot the opportunity, whether you are Plugging In the Answers or Plugging In for variables in the question, the technique begins with recognizing the opportunity and ends with your scratch paper. Variables in the answer choices are a trigger that should provoke the instant response of writing out your answer choices and labeling your terms. You should do this before you have even fully read the question because it will help organize your approach, give you a place to park the information, and set you up to succeed on the problem, no matter how difficult the problem is. The same is true for Plugging In the Answers. The hardest part is recognizing the opportunity. Once you see the

phrase “How much,” “How many,” or “What is the value of,” write out A, B, C, D, and E on your scratch paper, label the first column, and assume choice (C) to be the correct answer. Once you do this, you are already halfway through the problem. You must get your hand moving and make your set-ups on the scratch paper. When you get good at it, this will become an automatic habit and even the hardest problems will unfold quickly and accurately. Remember that practice and repetition make the habit, and scratch paper ensures that it happens, and happens correctly.

For a more thorough explanation of Plugging In, check our student-friendly guidebook, *Cracking the New GRE*, 2012 Edition.

DRILL 1

Question 1

The profit from selling y units of a product is given by the formula $4y - 2$, where $y > 0$.

Quantity A

4 times the profit from selling y units

Quantity B

$16y - 4$

- Quantity A is greater.
- Quantity B is greater.
- The two quantities are equal.
- The relationship cannot be determined from the information given.

Question 2

J is the set of all fractions in the form of $\frac{a}{a^2}$ where $a \neq 0$.

Quantity A

Any member of set J

Quantity B

1

- Quantity A is greater.
- Quantity B is greater.
- The two quantities are equal.
- The relationship cannot be determined from the information given.

Question 3

$$\begin{aligned}x^3 &= 27 \\y^2 &= 16\end{aligned}$$

Quantity A

x

Quantity B

y

- Quantity A is greater.
- Quantity B is greater.
- The two quantities are equal.
- The relationship cannot be determined from the information given.

Question 4

$$x > y > 0$$

Quantity A

$4x$

Quantity B

$5y$

- Quantity A is greater.

- Quantity B is greater.
- The two quantities are equal.
- The relationship cannot be determined from the information given.

Question 5

If $7(q - r) = 10$, what is q in terms of r ?

- $r + \frac{10}{7}$
- $r - \frac{10}{7}$
- $7r + 10$
- $10 - 7r$
- $7r + \frac{10}{7}$

Question 6

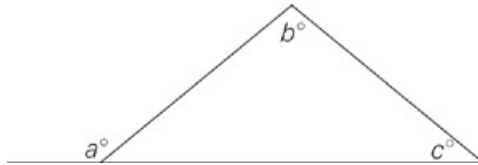

In the figure above, what is a in terms of b and c ?

- $180 - (b + c)$
- $180 + (b + c)$
- $(b + c)$
- $(b + c) - 180$
- $(b + c) + 180$

Question 7

Quantity A

$$3a^5$$

Quantity B

$$(3a)^5$$

- Quantity A is greater.
- Quantity B is greater.
- The two quantities are equal.
- The relationship cannot be determined from the information given.

Question 8

Jan and Marko are competing in an off-road race. Jan completes $\frac{3}{4}$ of the race in 2 hours. Marko completes $\frac{2}{3}$ of the race in $\frac{5}{8}$ of the time it takes Jan to complete $\frac{9}{10}$ of the race.

Quantity A

Jan's rate

Quantity B

Marko's rate

- Quantity A is greater.
- Quantity B is greater.
- The two quantities are equal.
- The relationship cannot be determined from the information given.

Question 9

$0 < a < 3$
 $-3 < b < 0$
a and b are integers.

Quantity A

a + b

Quantity B

a - b

- Quantity A is greater.
- Quantity B is greater.
- The two quantities are equal.
- The relationship cannot be determined from the information given.

Question 10

$0 < a < b < 1$

Quantity A

0

Quantity B

2(a - b)

- Quantity A is greater.
- Quantity B is greater.
- The two quantities are equal.
- The relationship cannot be determined from the information given.

Question 11

Rachel, David, and Kristen decide to pool their money to buy a video game system. David contributes 4 dollars more than twice what Kristen does, and Kristen contributes 3 dollars less than Rachel does. If Rachel contributes r dollars, then, in terms of r, how much does David contribute?

- $\frac{r - 7}{2}$
- $\frac{r - 2}{2}$
- $\frac{2r + 7}{2}$
- $2r - 2$

Question 12

If $x \neq 0$ and $y = \frac{x+1}{x} - 1$, what is $\frac{1}{y}$?

- x
 $\frac{1}{y}$
 $-x + 1$
 $\frac{x+1}{x-1}$
 $-(x+1)$

Question 13

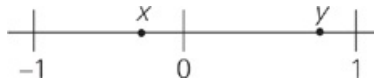

Quantity A

$$-\frac{x-3}{4}$$

Quantity B

y

- Quantity A is greater.
 Quantity B is greater.
 The two quantities are equal.
 The relationship cannot be determined from the information given.

Question 14

Quantity A

$$x + y - 1$$

Quantity B

$$x - y + 1$$

- Quantity A is greater.
 Quantity B is greater.
 The two quantities are equal.
 The relationship cannot be determined from the information given.

DRILL 2

Question 1

$$x > 1$$

Quantity A

$$5^x + 1$$

Quantity B

$$6^x$$

- Quantity A is greater.
- Quantity B is greater.
- The two quantities are equal.
- The relationship cannot be determined from the information given.

Question 2

At a crafts supply store, the price of a type of decorative string is c cents per foot. At this rate, what would be the price, in dollars, of y yards of this string?

- $\frac{cy}{300}$
- $\frac{100}{3cy}$
- $\frac{3y}{100c}$
- $\frac{3cy}{100}$
- $\frac{300}{cy}$

Question 3

$$x^2 = |y|$$

Quantity A

$$|x|$$

Quantity B

$$y$$

- Quantity A is greater.
- Quantity B is greater.
- The two quantities are equal.
- The relationship cannot be determined from the information given.

Question 4

Quantity A

$$\frac{a + b + c}{5}$$

Quantity B

$$\frac{1}{5ab} + \frac{c}{5}$$

- Quantity A is greater.
- Quantity B is greater.

- The two quantities are equal.
- The relationship cannot be determined from the information given.

Question 5

If a and b are positive and $\frac{ab}{x} = \sqrt{a}$, then $\frac{x}{\sqrt{b}} =$

- \sqrt{a}
- \sqrt{ab}
- $\sqrt{\frac{a}{b}}$
- $\sqrt{\frac{b}{a}}$
- a^2

Question 6

If m is an odd integer, which of the following expresses the number of even integers between m and 2m inclusive?

- $\frac{m}{2} + 1$
- $\frac{m}{2} - 1$
- $\frac{m+1}{2}$
- $\frac{m-1}{2}$
- $2m + 1$

Question 7

$$\frac{4+5}{5} = \frac{4}{5y}$$

Quantity A

$$\frac{8}{9y}$$

Quantity B

$$2$$

- Quantity A is greater.
- Quantity B is greater.
- The two quantities are equal.
- The relationship cannot be determined from the information given.

Question 8

$x < 0 < y$
x and y are integers.

$$\frac{w}{x}$$

$$\frac{y}{w}$$

- Quantity A is greater.
- Quantity B is greater.
- The two quantities are equal.
- The relationship cannot be determined from the information given.

Question 9

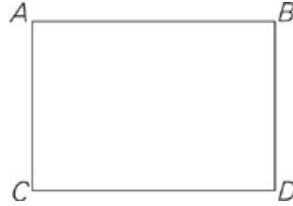

In rectangle ABCD, the length is 60 percent of the width.

Quantity A

$\frac{1}{10}$ area of rectangle

Quantity B

The length of the rectangle

- Quantity A is greater.
- Quantity B is greater.
- The two quantities are equal.
- The relationship cannot be determined from the information given.

Question 10

Two children named Peter and Wanda are playing a number game. If Peter's number z is 200 percent of Wanda's number, what is 20 percent of Wanda's number, in terms of z ?

- $10z$
- $2z$
- $\frac{z}{5}$
- $\frac{z}{10}$
- $\frac{z}{20}$

Question 11

What is the area of a circle whose circumference is x ?

- $\frac{x^2}{4\pi}$
- $\frac{x^2}{2\pi}$
- $\frac{x}{4\pi}$

- $\frac{x}{2\pi}$
- $2\sqrt{\pi x}$

Question 12

A rectangle has length $2x$ and width x . If each diagonal of the rectangle has length d , what is the area of the rectangle, in terms of d ?

- $\frac{2}{5}d$
- $\frac{5}{2}d$
- $\frac{4}{25}d^2$
- $\frac{2}{5}d^2$
- $\frac{2}{3}d^2$

Question 13

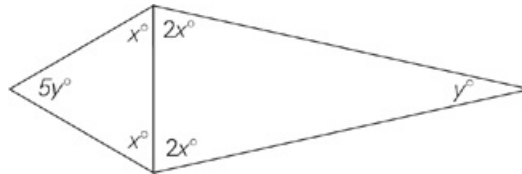

In the figure above, which one of the following is true?

- $x = 2y$
- $y = 2x$
- $x + y = 80$
- $x - y = 30$
- $x = y$

Question 14

$$130 < x < 150$$

Quantity A

The greatest odd factor of x

Quantity B

The greatest even factor of x

- Quantity A is greater.
- Quantity B is greater.
- The two quantities are equal.
- The relationship cannot be determined from the information given.

DRILL 3

Question 1

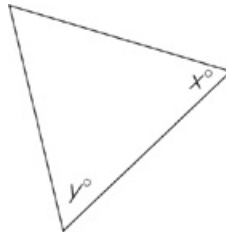

Quantity A

$$358 - 2(x + y)$$

Quantity B

$$180 - (x + y)$$

- Quantity A is greater.
- Quantity B is greater.
- The two quantities are equal.
- The relationship cannot be determined from the information given.

Question 2

$$pq \neq 0$$

Quantity A

$$(p + q)^3$$

Quantity B

$$p^3 + q^3$$

- Quantity A is greater.
- Quantity B is greater.
- The two quantities are equal.
- The relationship cannot be determined from the information given.

Question 3

$$\frac{y^2}{x^{12}} \text{ is an integer, } y > x > 1.$$

Quantity A

$$x^2$$

Quantity B

$$\sqrt{y}$$

- Quantity A is greater.
- Quantity B is greater.
- The two quantities are equal.
- The relationship cannot be determined from the information given.

Question 4

Let x , y , and z be non-zero numbers such that the average (arithmetic mean) of x and twice y is equal to the average (arithmetic mean) of y and twice z . What is the average (arithmetic mean) of x and y ?

- $\frac{z}{2}$
- z
- $2z$
- $z - x$
- $z - y$

Question 5

If $b = \frac{c + d^2}{c}$ and $a = \frac{c}{d^2}$, what is b in terms of a ?

- $1 + \frac{1}{a}$
- $1 + a$
- $\frac{1}{1 + a}$
- $a^2 + 1$
- $\frac{a}{a + 1}$

Question 6

$\frac{1}{r}$ of a circular pizza has been eaten. If the rest of the pizza is divided into m equal slices, then each of these slices is what fraction of the whole pizza?

- $\frac{r}{rm}$
- $\frac{r - 1}{rm}$
- $\frac{1}{m}$
- $\frac{m - 1}{rm}$
- $\frac{m - r}{rm}$

Question 7

Quantity A

$$(x + y)^2 - 2xy$$

Quantity B

$$x^2 + y^2$$

- Quantity A is greater.
- Quantity B is greater.
- The two quantities are equal.
- The relationship cannot be determined from the information given.

Question 8

If $\frac{1}{y} < x < 0$, then which one of the following must be true?

- $1 < x^2$
- $x^2 < x$
- $-1 < x^3 < 0$
- $\frac{1}{x} > -1$
- $x^3 < x$

Question 9

If $A = q - r$, $B = r - s$, and $C = q - s$, what is the value of $A - (B - C)$?

- $-r$
- 0
- 1
- $q + r$
- $2(q - r)$

Question 10



x and y are both integers

Quantity A

xy

Quantity B

6

- Quantity A is greater.
- Quantity B is greater.
- The two quantities are equal.
- The relationship cannot be determined from the information given.

Question 11

There are x red marbles, y blue marbles, and z yellow marbles in a sack. Three marbles are chosen at random, without replacements. If x , y , and z are all at least equal to 3, then which of the following must be true? Indicate all possible values.

- The probability of drawing exactly 3 red marbles is $\frac{x}{x+y+z} \cdot \frac{x-1}{x+y+z-1} \cdot \frac{x-2}{x+y+z-2}$
- The probability of drawing at least 1 red marble is $1 - \left(\frac{y+z}{x+y+z} \cdot \frac{y+z-1}{x+y+z-1} \cdot \frac{y+z-2}{x+y+z-2} \right)$

$$\frac{y}{x+y+z} \cdot \frac{y-x}{x+y+z-1} \cdot \frac{y+z}{x+y+z-2}$$

Question 12

The Lirr River runs from Rosedale in the west to Oceanside in the east with the current moving at an average of 10 miles per hour. Sasha is traveling by motorboat from Oceanside to Rosedale and back. If the water were not moving, Sasha's motorboat would travel at an average speed of 20 miles per hour. Given the current, what was Sasha's actual average speed, in miles per hour, for the round trip?

Question 13

If $a^{\frac{2}{3}} = b^{\frac{2}{3}}$ for $a \neq 0$ and $b \neq 0$, then which of the following statements must be true? Indicate all possible values.

- $\frac{a}{b} = 1$
- $\frac{a}{b} = -1$
- $\left(\frac{a}{b}\right)^2 = 1$
- $a = \frac{2}{3}$
- $a^2 = b^2$
- $\sqrt{a} = \sqrt{b}$

Question 14

If 7 orchids cost d dollars, then how many dollars will 10 orchids cost at the same rate?

- $70d$
- $\frac{70}{d}$
- $\frac{7}{10d}$
- $\frac{10d}{7}$
- $\frac{d}{70}$

DRILL 4

Question 1

Point A is located on a number line. If point A is between x and y, which are the values on the same number line, and if $0 < x < y$, which of the following could represent the position of point A on the number line?

Indicate all possible values.

- $x + 1$
- $x - 1$
- $y + 1$
- $y - 1$
- $x + y$
- $x - y$
- $y - x$

Question 2

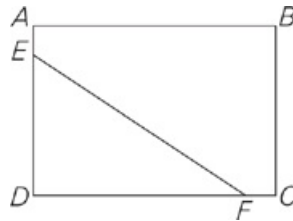

In the rectangle above, $AB = x$ feet, $BC = y$ feet, and $AE = FC = 2$ feet. What is the area of triangle DEF, in square feet?

- $\frac{xy}{2} + 2$
- $\frac{xy}{2} - x - y - 2$
- $\frac{xy}{2} - x - y + 2$
- $xy - 2x - 2y - 4$
- $xy - 2x - 2y + 4$

Question 3

If integer a is divisible by both 3 and 14, which of the following must be true?

Indicate all such statements.

- a is divisible by 6
- a is equal to 42
- a is divisible by 21
- a is positive

Question 4

Points A and B are separated by 50 miles on a straight road. Cyclist A leaves point A, heading toward point B, at a constant speed of 15 miles per hour. At the same time, cyclist B leaves point B, traveling toward point A, at a constant speed of 10 miles per hour. After how many minutes will the two meet?



Question 5

If $x < y$ and $0 < x + y$, which of the following must be negative?
Indicate all possible values.

- $-x$
- $-y$
- $x - y$
- $(x - y)^2$
- $2x - y$

Question 6

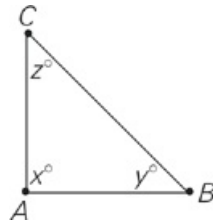

In $\triangle ABC$ above, $x < y + z$. What is one possible value of x ?



Question 7

If p is a negative even integer and q is a positive odd integer, which of the following must be true?

- pq is a negative odd integer.
- $\frac{p}{q}$ is a negative odd integer.
- $p - q$ is a positive odd integer.
- $p + q$ is a positive odd integer.
- $q - p$ is a positive odd integer.

Question 8

If f is a fraction between -1 and 1 , which of the following must be true?

- $f^7 < f^5$
- $f^6 - f^7 < f^4 - f^5$
- $f^6 + f^7 < f^5 + f^4$
- $(-f)^3 < f^3$
- $f^6 < f^4$

Question 9

At Pedantic Publishing Corporation, $\frac{1}{5}$ of the employees take the bus to work and $\frac{1}{3}$ drive to work. Of the employees who do not take

the bus or drive to work, $\frac{1}{4}$ take the subway and the rest either walk or ride a bicycle. If $\frac{1}{7}$ of the remaining employees ride a bicycle.

to work, what fraction of the employees walks to work?

Question 10

$$\frac{8x^{21} + 12x^{20} - 108x^{19} + \sqrt{36x^4}}{2x} = 3x$$

Which of the following values of x satisfy the above equation?

- 6
- 4.5
- 3
- 0
- 3
- 4.5
- 6

Question 11

Brian spent $\frac{1}{4}$ of his paycheck to repair his car, and then paid the registration and insurance, which each cost $\frac{1}{3}$ of the remainder of his paycheck. If Brian had \$0 before he was paid, and he now has \$231 left, what was the amount of his paycheck?

- \$2772
- \$1622
- \$924
- \$870
- \$693

Question 12

If a is 60% of b, b is 40% of c, and c is 20% of d, then 6d is what percent of 20a?

--

Question 13

If $1 \leq n \leq 100$, and $\frac{n+7}{2}$ is a multiple of 4 but not a multiple of 3, then which of the following could be true?

Indicate all possible values.

- n is even
- n is odd
- n is prime

- n is a multiple of 3
- n is a multiple of 4

ANSWERS

Drill 1

1. B
2. D
3. D
4. D
5. A
6. C
7. D
8. B
9. B
10. A
11. D
12. A
13. D
14. D

- Drill 2
1. B
 2. D
 3. D
 4. D
 5. B
 6. C
 7. B
 8. D
 9. D
 10. D
 11. A
 12. D
 13. A
 14. A

Drill 3

1. D
2. D
3. B
4. B
5. A
6. B
7. C
8. C
9. E
10. B
11. A, B
12. 15
13. C, E
14. D

Drill 4

1. A, D, G
2. C
3. A, C
4. 120
5. B, C
6. $0 < x < 90$
7. E
8. B, C, E
9. $3/10$
10. B, E
11. C
12. 625
13. B, C, D

Drill 1

1. B The minute you see variables, make your set-up. Plug in something happy for y to start with, such as 2. Quantity A is $4 \times 6 = 24$ and Quantity B is $16(2) - 4 = 28$. Quantity B is greater, so eliminate choices (A) and (C) on your scratch paper. Use ZONEF to try fractions, large numbers, and one. No matter what you plug in, choice (B) is greater. The answer is choice (B).
2. D The minute you see variables, make your set-up. You're dealing with exponents, so try starting with 1. When $a = 1$, Quantity A is equal to 1 and Quantity B is one. Both quantities are equal so eliminate choices (A) and (B). Now see if you can screw it up by Plugging In a fraction. If you plug in $\frac{1}{2}$, Quantity A will still equal 1. You're not allowed to plug in 0, so try a regular old integer to see what it does. If you plug in 4 you end up with $\frac{1}{4}$ for Quantity A. Since B is now greater than Quantity A, you have inconsistent results and must choose (D).
3. D The minute you see variables, make your set-up. This problem looks suspiciously simple. Clearly $x = 3$ and $y = 4$. Eliminate choices (A) and (C). Your set-up, however, tells you to Plug In more than once. Is there anything else you could plug in? Yes, the square root of 16 could be either 4 or -4 . Go through the motions to make sure you don't miss any options. Because y could be negative, eliminate choice (B), leaving you with choice (D) for the answer.
4. D The minute you see variables, make your set-up. Start with something easy like $x = 2$ and $y = 1$. Quantity A is bigger, so eliminate choices (B) and (C). Use ZONEF to figure out what to plug in next. Zero is out, you tried 1, and negative numbers are out. Try extremely large numbers, such as 100 and 101. When you do this Quantity B becomes bigger, so the answer is choice (D). You could also have used a non-integer such as 1.1.
5. A It's a little difficult to Plug In on this one because you have to pick numbers that make $7(q - r) = 10$ true. First divide both sides by 7 to find $q - r = \frac{10}{7}$. Then add r to both sides to find $q = \frac{10}{7} + r$ or $q = r + \frac{10}{7}$.
6. C Algebraically, both a and $b + c$ are equal to 180 minus the unnamed angle in the triangle. Like most relationships that involve both algebra and geometry, though, this is most easily seen by Plugging In values for the angles. If $a = 110$, for instance, the unnamed angle in the triangle must be 70° . You have no specific information for b or c , so plug in 60 for b : c must now be 50, and because a equals the sum of b and c , select choice (C). Plugging In numbers may also make it easier to notice that choices (B) and (E) are identical and, therefore, can be eliminated.
7. D The minute you see variables, make your set-up. Start with something easy but interesting with exponents, such as 1. When $a = 1$, Quantity A is 3 and Quantity B is something much larger than 3. Don't take the time to bother calculating; just eliminate choices (A) and (C). When you try another basic integer, you get the same result. Fractions less than 1 get smaller when multiplied, so try $\frac{1}{3}$. Quantity B is still bigger. Check ZONEF to see if there is anything you haven't tried yet. There is, so plug in 0 for a . In this case, both quantities are equal. Eliminate choice (B) and select choice (D).
8. B To solve this question, Plug In a value for the race's distance. Here, you want a number that is divisible by 3, 4, 8, and 10, such as 120. If the race is 120 miles, then since Jan completes $\frac{3}{4} \times 120 = 90$ miles in 2 hours, and her speed is 45 miles per hour. Now for Marko's rate. Since Jan's rate is 45 miles per hour, and the race is 120 miles, you can set up a proportion to find her time: $\frac{45 \text{ miles}}{1 \text{ hour}} = \frac{90}{x \text{ hours}}$. $\frac{90}{100} \times 120 \text{ miles}$ or $\frac{45 \text{ miles}}{1 \text{ hour}} = \frac{108 \text{ miles}}{x \text{ hours}}$; $x = \frac{12}{5}$, so it takes Jan $\frac{12}{5}$ hours to complete $\frac{9}{10}$ of the race. Marko thus completes $\frac{2}{3} \times 120 = 80$ miles in $\frac{5}{8} \times \frac{12}{5} = \frac{3}{2}$ hours. This means that Marko's rate, expressed as $\frac{\text{miles}}{\text{hours}}$, is $\frac{80}{\frac{3}{2}} = \frac{80}{1} \times \frac{2}{3} = \frac{160}{3} = 53.33$ miles per hour.

Marko has the higher rate, so the correct answer is choice (B).

= -1, and in Quantity B the difference is $1 - (-2) = 3$; Quantity B is greater, so eliminate choices (A) and (C). Now try other allowable values for a and b; any acceptable value gives the same outcome, so select choice (B). 

10. A Solve this one by Plugging In values for a and b. Try making $a = \frac{1}{4}$ and $b = \frac{1}{2}$: The value in Quantity B is now $2\left(\frac{1}{4} - \frac{1}{2}\right) = 2\left(-\frac{1}{4}\right) = -\frac{1}{2}$. Quantity A is greater, so eliminate choices (B) and (C). Because b is bigger than a, $(a - b)$ will always be negative, so any other allowable values for a and b will yield the same results; thus, Quantity A is greater.
11. D Plugging In is the best approach to this question: Start with a value for r and build from there. If $r = 6$, then Kristen contributes 3 dollars less than r, or \$3, and David contributes twice as much as Kristen plus 4 more, or $6 + 4 = \$10$. Now plug in 6 for r in the answer choices, and only choice (D) hits your target answer of 10: $2r - 2 = 2(6) - 2 = 12 - 2 = 10$.
12. A The minute you see variables in the answer choices, write your answer choices down on your scratch paper and Plug In. Start with something for x such as 2. When $x = 2$, y will equal $\frac{1}{2}$. You are asked to find $\frac{1}{y}$, so your target number is 2. Check all answer choices, and you'll find that choice (A) is the only one that works.
13. D The minute you see variables, make your set-up. In this case, plug in values that look about right for x and y. Try $x = -\frac{1}{4}$ and $y = \frac{3}{4}$. Quantity A will be greater, so eliminate choices (B) and (C). Now vary your numbers slightly and try $-\frac{1}{8}$ and $\frac{7}{8}$. In this case, Quantity B is greater. Eliminate choice (A) and select choice (D).
14. D The minute you see variables in a Quant Comp, make your set-up. Start with something simple such as $x = 10$ and $y = 1$. Quantity A equals 10 and Quantity B equals 10. Cross off choices (A) and (B). You're adding and subtracting so try flipping the numbers to see if you can get a negative number, so $x = 1$ and $y = 10$. Now Quantity A still equals 10, but Quantity B equals -8. Your answer is choice (D).

1. B The minute you see variables, make your set-up. Start with something nice and happy such as $x = 2$. On the left you get 26 and on the right you get 36. Cross off choices (A) and (C). The bigger x gets, the more it will exaggerate the difference. 6 to the 50th power, for example, will be way bigger than 5 to the 50th power plus 1. Can you get smaller? x still has to be greater than 1 so try $x = \frac{3}{2}$. It's a bit of a pain, but it's worth it just to make sure. At $x = \frac{3}{2}$, Quantity A = 12 and Quantity B = 14.69. Quantity B is still bigger. It's safe to pick choice (B).
2. D If the string costs c cents per foot, then it costs $3c$ cents per yard (because 1 yard = 3 feet). So the price of y yards of the string will be $3cy$ cents. Dividing this by 100 (to convert from cents per dollars), the cost of the string will be $\frac{3cy}{100}$ dollars, choice (D). Alternatively, you can plug in values for the variables for example, let $c = 100$ and $y = 2$. Then the price of the string is 100 cents (or 1 dollar) per foot. It follows that the string is 3 dollars per yard, so the price of 2 yards would be 6 dollars. If you now Plug In $c = 100$ and $y = 2$ into the answer choices, the only one that equals 6 is choice (D).
3. D The minute you see variables, make your set-up. Try something easy first, like 2. When $x = 2$, then $y = 4$; eliminate choices (A) and (C). Generally when you square something it gets larger, but that is not always the case. You have been given no rules for what you can plug in; therefore use ZONEF and try 1 or 0 or a fraction. Any of those options will allow you to eliminate choice (B). Therefore, the answer must be choice (D).
4. D The minute you see variables, make your set up. Start with some basic numbers such as 2, 3, and 5. Quantity A is 2 and Quantity B is $1\frac{1}{30}$. Eliminate choices (B) and (C). How could you make Quantity B larger? Negative numbers might help by making Quantity A smaller and Quantity B larger. Try -2 , -3 , and something much larger like -20 . Now Quantity A is 3 and Quantity B is $4\frac{1}{30}$, so eliminate choice (A), leaving you with choice (D) for the answer.
5. B You have variables in the question and in the answer, so clearly you're Plugging In. Since you have an a on both sides of the equal sign, start there with something nice and happy, such as $a = 4$. You know you're going to have to square b , so plug in a perfect square such as $b = 9$. This makes $x = 18$. Your target number, therefore, is 6. Only choice (B) works.
6. C Variables in the question and the answer choices tell you this is a Plug In question. Try something simple like $m = 3$. Between 3 and 6 inclusive there are two even integers. 2 is your target number. Now check the answer choices. Anywhere you see an m , plug in 3 and you're looking to get 2 as an answer. Only choice (C) works.
7. B The minute you see variables, make your set-up. The first thing to do is to clean up the expression and isolate the variable. When you do this, you end up with $\frac{4}{9} > y$. Now you can start Plugging In. Try something nice and easy for y . Quantity B is 2, so start by Plugging In 2, making Quantity A $1\frac{7}{8}$, while Quantity B is 2. Eliminate choices (A) and (C). Can you beat 2 in Quantity A? Plug in something larger than 2 for y , but remember that you can't go above $\frac{9}{4}$. Try $\frac{17}{8}$. This gets you closer but doesn't close the gap. How about $\frac{35}{16}$? Closer still, but you're still running a losing race. As long as you can only use $\frac{8}{9}$ of y , you'll never make it back to 2, so select choice (B).
8. D The minute you see variables, make your set-up. Plug in some nice easy numbers to start. Try $w = 1$, $x = -2$, and $y = 1$. Quantity A works out to $\frac{1}{2}$ and Quantity B works out to 1. Eliminate choices (A) and (C). You've been given a rule for what you can plug in for x and y , but no rules for w . The question addresses positive versus negative numbers, so plug in a negative number for w . Try $w = -1$,

$x = -2$, and $y = 4$. When you do this Quantity A is $-\frac{1}{2}$ and Quantity B is -4 . $-\frac{1}{2}$ is bigger, so eliminate choice (B). The answer is

choice (D).

9. D First, try plugging in some easy numbers for the length and width that obey the restrictions, such as 6 and 10. The area of the rectangle is 60, so the two columns are equal. Eliminate choices (A) and (B). Now try plugging in different numbers, such as 12 and 20. This time, column A is greater, so the answer must be choice (D).
10. D Plug in 100 for z : now, Wanda's number is 50 and 20 percent of her number is 10. Now plug in 100 for z in the answer choices; only choice (D) hits your target answer of 10.
11. A Variables in the question and the answer choices tell you this is a Plug In question. Since it represents a circumference, pick something that makes it easy to find the radius. Try $x = 8\pi$. That means that the radius of the circle is 4 and the area is 16π . This is your target number. Write it down and circle it. Now check all of the answer choices. Anywhere you see an x , plug in 8π . You're looking for 16π . Only choice (A) works.
12. D Variables in the question and the answer choices tell you this is a Plug In question. Try plugging in $x = 2$. The diagonal of this rectangle makes a 30-60-90 triangle. We know this because we have a right triangle with a side of x and another side of $2x$. The hypotenuse therefore must be $x\sqrt{3}$. $d = 2\sqrt{3}$. The area of the rectangle is 8. This is your target number. Write it down and circle it. Now check all of the answer choices. Anywhere you see a d , plug in $2\sqrt{3}$. Only answer choice (D) works.
13. A In the left triangle, you have $x + x + 5y = 180$, and in the right triangle, you have $2x + 2x + y = 180$. Because both these sums equal 180, they must be equal to each other: $x + x + 5y = 2x + 2x + y$. This equation simplifies to become $x = 2y$, choice (A).
14. A The minute you see variables, make your set-up. The question here is what to plug in. You could start with any integer between 130 and 150. You are looking for the greatest factors, so you might as well start with the greatest integer which is 149. The largest factor of 149 is 149, which is odd. If you use 148, the largest factor is 148, but that is smaller than 149. If you use 147, the largest factor is 147, still smaller. 149 is the largest factor of the largest number in your set, so you are done. The answer is choice (A).

Drill 3

1. D The minute you see variables, make your set-up. When you draw your shape, label the third angle of the triangle z . In general, when you have 2 angles of a triangle, go ahead and find the third angle, because it is likely to come in handy. For this problem, it might be easier to Plug In for angle z . When you have geometry on Quant Comp, you usually need to draw your shape in different ways and really exaggerate the differences. In this case, make z something really small, like 2. Quantity A will be 2 and Quantity B will also be 2. Eliminate choices (A) and (B). Now exaggerate the difference between possible triangles and make z a really large value, like 178. Quantity A will be 354 and Quantity B will be 178. Eliminate choice (C) and select choice (D).
2. D The minute you see variables, make your set-up. Start with happy numbers for p and q such as $p = 1$ and $q = 2$. Quantity A will equal 27 while Quantity B will equal 9. Cross off (B) and (C). Try some fractions such as $p = \frac{1}{2}$ and $q = \frac{1}{4}$. Quantity A will equal $\frac{27}{64}$ while Quantity B will equal $\frac{9}{64}$. Quantity A is still bigger. Use ZONEF and try some negative numbers such as $p = -3$ and $q = -2$. Quantity A will equal -125 and Quantity B will equal -35 . -35 is bigger. Cross off choice (A). The answer is choice (D).
3. B The minute you see variables, make your set-up. Because x^{12} is such a large number use a small value for x , such as 2. You now have a fraction with twelve 2's on the bottom. For this fraction to be an integer, y must be a number that contains at least six 2's. To keep it simple, try $y = 2^6$. Quantity A is 4 and Quantity B is 2^3 or 8. Eliminate choices (A) and (C). You can add more 2's or any other number to the top of this fraction as long as y contains six 2's. Therefore, y can only get bigger; it cannot get smaller. The answer is choice (B).
4. B Variables in the question and the answer choices tell you this is a Plug In question. Plug in, but make sure you follow the rules set up in the question. If you start with something simple, like $x = 2$ and $y = 3$ then the average of $x + 2y = 4$, which is equal to the average of $y + 2z$, so $3 + 2z = 4$. z must therefore equal 2.5. You're asked to find the average of x and y , which is also 2.5. Write down 2.5 and circle it. This is your target number. Go to the answer choices and plug in a 2.5 wherever you see a z . The answer choice that equals 2.5 is the correct one. The answer is choice (B).
5. A Plug In for c and d , in both equations, and solve for a and b . If $c = 8$ and $d = 4$, then $a = \frac{1}{2}$ and $b = 3$. Now plug in 8 for c and 4 for d in the answer choices; only choice (A) hits your target answer of 3.
6. B To solve this one, Plug In for r and m : Try $r = 2$ and $m = 4$. If $\frac{1}{2}$ of the pizza has been eaten, and the remaining $\frac{1}{2}$ is divided into 4 equal slices, then each of those remaining pieces is $\frac{1}{8}$ of the whole pizza. Now plug in 2 for r and 4 for m in the answer choices; only choice (B) hits your target answer of $\frac{1}{8}$.
7. C If you recognize the common quadratics, you know that $(x + y)^2 = x^2 + 2xy + y^2$; hence, $x^2 + 2xy + y^2 - 2xy = x^2 + y^2$. Thus, the two quantities are equal. Alternately, you could plug in values for x and y : If $x = 2$ and $y = 3$, then Quantity A equals $25 - 12 = 13$, and Quantity B equals $4 + 9 = 13$. Any set of values gives the same outcome, so select choice (C).
8. C Choose a value for x that satisfies the conditions of the question: $x = -\frac{1}{2}$, for example. Substituting this value into the answer choices, you see that all of the choices are false, except for choice (C).
9. E It's very easy to make a careless error on this one. Make sure to Plug In and write your work down in an organized manner. Try $q = 10$, $r = 5$, and $s = 2$. So, $A = 10 - 5 = 5$, $B = 5 - 2 = 3$, and $C = 10 - 2 = 8$. So, $A - (B - C) = 5 - (3 - 8) = 5 - (-5) = 10$. Only choice (E) yields 10 when you plug in 10 for q and 5 for r .
10. B As soon as you see variables and Quant Comp, make your set-up. Plugging In is tricky here until you realize that one number must be negative. The 6 in Quantity B is also a clue. Try $x = 3$ and $y = -2$. y to the x power will be -8 and x to the y power will be $\frac{1}{9}$, so these numbers work. $xy = -6$ so cross off choices (A) and (C). No matter what you plug in, and there are very few options, y must be negative and x must be odd. Therefore xy will always be negative and 6 will always be greater. The answer is choice (B).
11. A and B

probability of drawing exactly 3 red marbles is $\frac{6}{15} \times \frac{5}{14} \times \frac{4}{13} = \frac{1 \times 1 \times 4}{1 \times 7 \times 13} = \frac{4}{91}$. Plugging the values into choice (A) gives an answer

that matches our target number, so choice (A) works. The probability of drawing at least 1 red marble is best calculated by finding the probability of drawing no red marbles and subtracting that result from 1: $1 - \left(\frac{9}{15} \times \frac{8}{14} \times \frac{7}{13}\right) = 1 - \left(\frac{3}{5} \times \frac{4}{7} \times \frac{1}{13}\right) = \frac{65}{65} - \frac{12}{65} = \frac{53}{65}$.

Plugging the values into choice (B) gives an answer that matches our target number, so choice (B) works. The probability of drawing exactly 3 blue marbles is: $\frac{5}{15} \times \frac{4}{14} \times \frac{3}{13} = \frac{1 \times 2 \times 1}{1 \times 7 \times 13} = \frac{2}{91}$. Plugging the values into choice (C) gives $\frac{5}{15} \times \frac{5-4}{14} \times \frac{6+4}{13} = \frac{1 \times 1 \times 5}{3 \times 7 \times 13} = \frac{5}{273}$, which does not match our target. Choices (A) and (B) are correct.

12. 15 To answer this question, Plug In. Here, the unknown is the distance traveled; pick a value that works well with the numbers in this question, such as 60 miles. When Sasha is traveling from Oceanside to Rosedale, the current adds 10 miles per hour to her boat's "still water" speed, and thus she travels at 30 miles per hour. Therefore, it takes her $60 \div 30 = 2$ hours. When Sasha is traveling back, she is moving "against" the current, so her speed is 10 miles per hour less, and she thus travels at 10 miles per hour. Therefore, it takes her $60 \div 10 = 6$ hours. Altogether, she travels $\frac{60 \text{ miles} + 60 \text{ miles}}{2 \text{ hours} + 6 \text{ hours}} = \frac{120 \text{ miles}}{8 \text{ hours}} = 15$ miles per hour.

13. C and E
For questions that ask about what must be true, you should plan to Plug In more than once. Given the exponents in the question, you want to choose numbers for a and b that are easy to find the cube root for. So, let's choose a = 8 and b = 8.

$$(a)^{\frac{2}{3}} = (8)^{\frac{2}{3}} = (\sqrt[3]{8})^2 = (2)^2 = 4$$

$$(b)^{\frac{2}{3}} = (8)^{\frac{2}{3}} = (\sqrt[3]{8})^2 = (2)^2 = 4$$

$$4 = 4$$

When you plug 8 into your answer choices, you are able to eliminate choices (B) and (D). Plug In again, but this time change your plugged in value to b = -8. You should still have $a^{\frac{2}{3}} = b^{\frac{2}{3}}$, but you can now additionally eliminate choices (A) and (F). This leaves choices (C) and (E) as the answers.

14. D Plug In. If you choose d = 14, then 7 orchids cost 14 dollars. Since $14 \div 7 = 2$, one orchid must cost 2 dollars. If one orchid costs 2 dollars, then 10 orchids cost 20 dollars. This makes 20 your target. Use d = 14 for the answer choices. Choice (A) is 70×14 . This is obviously too big. Choice (B) is $70 \div 14$, which is also not equal to twenty. Choice (C) is $7 \div 10 \times 14$, which is a fraction, therefore not equal to 20. Choice (D) would be $14 \times 10 = 140$, which you then divide by 7. Since $140 \div 7 = 20$, this matches your target. Keep choice (D), but remember to check all five choices on Plugging In problems. Choice (E) would be $14 \div 70$, which is not equal to 20. Only choice (D) matches your target, so choice (D) is the correct answer.

1. A, D, and G

Plug in numbers for x and y to solve this problem. Drawing your own number line will also help. If you choose $x = 4$ and $y = 10$, then point A will be on the number line between 4 and 10. Choice (A) would be $4 + 1$, which equals 5. Since 5 is on the number line between 4 and 10, this could work, so select choice (A). Choice (B) would be $4 - 1$, which equals 3. This is not between 4 and 10. Eliminate choice (B). Choice (C) would be $10 + 1$. 11 is not on the number line between 4 and 10. Eliminate choice (C). Choice (D) would be $10 - 1$. Since 9 is on the number line between 4 and 10, this could work, so select choice (D). Choice (E) would be $4 + 10$. 14 is not on the number line between 4 and 10. Eliminate choice (E). Choice (F) would be $4 - 10$. -6 is not on the number line between 4 and 10. Eliminate choice (F). Choice (G) would be $10 - 4$. 6 is on the number line between 4 and 10, so it could work. Select choice (G).

2. C Plug in your own numbers for x and y . If $x = 4$ and $y = 5$, then the sides of the triangle are 2 and 3. The area of a triangle = $\frac{1}{2}bh$, so the triangle has an area of 3. Circle 3 as your target. Plugging In shows you that only choice (C) matches your target.

3. A and C

Plug In for a. If $a = -42$, then it is divisible by 6 and 21 but is not positive or equal to 42, so you can eliminate choices (B) and (D). If $a = 84$ it is still divisible by 3 and 14, as well as by 21 and 6. In fact, a will always be divisible by 6 and 21, because the prime factors of 3 and 14 are 2, 3, and 7 and the distinct prime factors of 6 and 21 are also 2, 3, and 7. The correct answers are choices (A) and (C).

4. 120 Cyclists A and B start 50 miles apart and are heading at each other at 15 and 10 miles per hour, respectively. Remember the distance equation is $d = r \times t$. The rates at which the two travel are different, so the distances they will travel will be different; however, since they start at the same time and will meet at the same time (obviously!), their times will be the same. Therefore we can write both of their distance equations:

$$(1) d_A = 15 \times t,$$

$$(2) d_B = 10 \times t.$$

Since their distances together must equal 50 miles, we also know that:

$$(3) d_A + d_B = 50.$$

Now we have three equations with three variables, which means you can use your favorite technique for solving simultaneous equations to find the answer for t . One way is to plug equations (1) and (2) into (3), finding:

$$15 \times t + 10 \times t = 50.$$

Now solve for t , finding $t = 2$. But wait! You're not quite done yet. Their speeds were given in miles per hour, and the question asks for the answer in minutes, so you must do a quick conversion: $2 \text{ hours} \times 60 \text{ minutes/hour} = 120 \text{ minutes}$, which is the correct answer.

5. B and C

Use Plugging In to solve this problem. Start by plugging in simple numbers, and keep all the choices that come out negative. If you choose $x = 2$ and $y = 3$, then you would keep choice (A), which would equal -2 , and choice (B), which would equal -3 . Since $-2 - 3 = -5$, you would keep choice (C). Choice (D) is the same as choice (C), but squared. $(-5)^2 = 25$, so eliminate choice (D). Choice (E) would work out to $2(2) - 3$, which equals 1, so eliminate choice (E). Because the problem says "must be," you will have to Plug In more than once. Try negative this time. If you choose $x = -2$ and $y = 3$, $x + y = -2 + 3 = 1$, so the requirements of the problem are still met. In this case $-x$ is now positive 2, so eliminate choice (A). Choice (B) is still positive, and now you can see that even though x can be negative, y must always be positive to make $0 < x + y$, so you can always keep choice (B). Choice (C) calculates to $-2 - 3 = -5$. You can see that a small number minus a bigger number will always come out to be negative, so keep choice (C).

6. $0 < x < 90$

This problem has a misleading figure. Even though x looks like a right angle, it may not be exactly 90 degrees. Use Plugging In to help you. Since all angles of a triangle must add up to 180° , $x + y + z = 180$. Since x has to be less than $y + z$, make y and z add up to be pretty big. For example, you could use $y = 50$ and $z = 60$. If you plug in these numbers, then you can calculate x by adding 50 to 60 to get 110. Then subtract from 180. $180 - 110 = 70$. This is one possible value of x .

7. E Variables in the answer choices mean Plug In, and the phrase "must be" means you'll likely have to plug in more than once. Start

with $p = -2$ and $q = 3$: Eliminate choice (A), because $pq = -6$; eliminate choice (B), because $\frac{p}{q} = -\frac{2}{3}$ and eliminate choice (C),

because $p - q = -5$. Choices (D) and (E) both work, though, so use new values to test the remaining answers. Try $p = -4$ and $q =$

1; now $p + q = -3$, so eliminate choice (D). Only choice (E), the correct answer, remains.

8. B, C and E

Since the problem asks for what must be true, plug in more than once to make sure your final choices are always true. First, let's say f

$= \frac{1}{2}$. Use your calculator to calculate each answer choice. All five choices are true. Now plug in $f = -\frac{1}{2}$. This time you eliminate

choices (A) and (D). The correct answer is choices (B), (C), and (E).

9. $\frac{3}{10}$ Plug In for the total number of employees in the company. If there are 60 employees, then the number of employees who take the

bus to work equals $60 \times \frac{1}{5} = 12$, and the number of employees who drive to work equals $60 \times \frac{1}{3} = 20$. $60 - 12 - 20 = 28$ left who neither take the bus nor drive to work. $\frac{1}{4}$ of these employees take the subway, so there are $28 \times \frac{1}{4} = 7$ employees who ride the subway. $28 - 7 = 21$, so there are 21 employees remaining. $\frac{1}{7}$ of those employees ride a bicycle, so there are $21 \times \frac{1}{7} = 3$ employees who ride a bicycle. $21 - 3 = 18$, so there are 18 employees who walk to work. $\frac{18}{60} = \frac{3}{10}$, which is the correct answer.

10. B and E

This looks like a good opportunity to Plug In the Answers and see which ones work, but you'll want to start with some algebra to get rid of the huge exponents in the numerator. First, get rid of the denominator by multiplying both sides by $2x$. Now, notice that the term under the radical can be simplified to $6x^2$, which—thankfully—is exactly what is on the other side of the equation. Cancel them, and now you have $8x^{21} + 12x^{20} - 108x^{19} = 0$. What are the common factors of each of the three terms? 4 and x^{19} . Factoring them out yields: $4x^{19}(2x^2 + 3x - 27) = 0$. It may appear that $x = 0$ is one of your solutions; however, $x = 0$ would make the denominator on the left side of the original equation equal to zero, and thus undefined, so $x = 0$ is not an acceptable solution. Eliminate choice (D). However, you also have a quadratic equation, which, if it can be made to equal zero, renders the other term meaningless. If you're good at factoring quadratics, you might notice that this one factors to $(2x + 9)(x - 3)$, giving choices (B), -4.5 , and (C), 3 . If you're not comfortable factoring—or just don't feel like it—use your on-screen calculator to start Plugging In the Answers. Don't worry about the $4x^{19}$ term: As long as what's inside the parentheses is zero, it doesn't matter what it gets multiplied by.

11. C It's an algebra question with numbers for answer choices, so set up your scratch paper to Plug In the Answers. Start with choice (C). If

Brian's paycheck was \$924, and he spent $\frac{1}{4}$ on the repair, then he spent \$231, leaving him with \$693; the insurance and registration each cost $\frac{1}{3}$ of the balance, or \$231, so he spends another \$462, leaving him with $\$693 - \$462 = \$231$. This matches the information in the question, so choice (C) is correct.

12. 625 Combine Plugging In and percent translation to attack this difficult problem. Meet the first requirement by making $a = 60$ and $b =$

100 . Since b is 40% of c , $100 = \frac{40}{100} \times c$, and $c = 250$; c is 20% of d , so $250 = \frac{20}{100} \times d$ and $d = 1250$. Now use your assigned values to translate the last part of the question: $6(1250) = \frac{x}{100} \times 20(60)$, so $7500 = \frac{x}{100} \times 1200$, $7500 = 12x$, and $x = 625$.

13. B, C, and D

Variables in the answer choices mean Plug In, and don't worry if you don't immediately see easy values to use for n . Try plugging a number into the given requirement and solve for n : $\frac{n+7}{2} = 4$, so $n = 1$. You already know choice (B) can be true, but find a few more values: $\frac{n+7}{2}$ yields $n = 9$, so now you know choice (D) can be true; note, however, that $\frac{n+7}{2} \neq 12$, since 12 is a multiple of 3, so $n \neq 17$. You can try more, but the 3 values you now have—1 and 9, but not 17—are enough to establish a pattern: Increase by 8, but eliminate every third term. The rest of the list is thus 25 and 33, but not 41; 49 and 57, but not 65; 73 and 81, but not 89; and 97. Since 73 and 97 are both prime, choice (C) can be true as well.



PITA and Hidden Plug-In Drill

Question 1

A new release DVD rental costs d dollars for 1 day and \$5.00 for each additional day. The first two days of standard release rental costs \$3.00 less than the first day of a new release rental, and \$2.25 for each day thereafter. Carl rented two new releases and one standard release for five days and it cost him \$61.75. What is the value of d ?

- \$5.25
- \$4.50
- \$5.25
- \$6.00
- \$6.75

Question 2

If 3 less than twice a certain number is equal to 2 more than 3 times the number, then 5 less than 5 times the number is

- 30
- 20
- 5
- 0
- 20

Question 3

A sports league encourages collaboration by awarding 3 points for each goal scored without assistance and 5 points for each goal scored with assistance. A total of 48 points were scored by a team in a single game. Which of the following CANNOT be the number of goals scored without assistance by this team in this game?

- 1
- 6
- 11
- 12
- 16

Question 4

Melinda and Shirley worked together to make hamburger patties. Shirley worked for 1 hour and 45 minutes, Melinda worked for 45 minutes, and they split their earnings according to the amount of time each spent working. Melinda's hourly rate, however, is twice that of Shirley's. If the two together earned \$48.75, what was Shirley's hourly rate?

- \$15
- \$20
- \$25
- \$30
- \$35

The 200 seventh graders at John Witherspoon Middle School raised 80% of the funds needed for a field trip. The school donated the remaining 20%. When they went to purchase the tickets, however, they were given a 10% bulk rate discount after a \$20 processing fee. Faced with an unexpected surplus the students chose to buy each member of the class one cookie and were still left with \$18, which they gave to the bus driver. If each of the cookies cost \$0.30, how much did the trip cost the school?

- \$40
- \$80
- \$120
- \$160
- \$200

Question 6

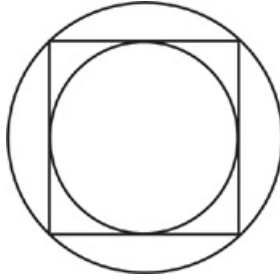

The figure above shows a circle inscribed in a square which is in turn inscribed within a larger circle. What is the ratio of the area of the larger circle to that of the smaller circle?

- $\sqrt{2}$
- $\frac{\pi}{2}$
- $\frac{\pi^2}{4\sqrt{2}}$
- 2
- $\frac{\pi}{\sqrt{2}}$

Question 7

At a restaurant, all tips are added together to be split among the employees at the end of a shift. The 4 waiters combined get $\frac{2}{3}$ of the money, the manager receives $\frac{1}{4}$ and the busboy receives the remainder. If 1 waiter and the busboy together receive \$30, how much money was earned in tips for the entire shift?

- \$90
- \$96
- \$108
- \$120
- \$180

Question 8

If $\sqrt{x+3} = \sqrt{x} + \sqrt{3}$, then x is

- 3
- 0
- $\sqrt{3}$
- 3
- any non-negative real number

Question 9

If n is positive, $\frac{n}{m} = 4$ and $mn = 9$, then $m =$

- $\frac{1}{6}$
- $\frac{2}{3}$
- $\frac{3}{2}$
- 6
- $\frac{27}{2}$

Question 10

During a sale, the original price of a garment is lowered by 20%. Because the garment did not sell, its sale price was reduced by 10%. The final price of the garment could have been obtained with a single discount by $x\%$ from the original price, where $x =$

- 25
- 26
- 27.5
- 28
- 30

Question 11

At Betty's Bagels, bagels normally cost x each, but with purchases of each dozen the customer receives a discount of 1.40 dollars. Billy buys 56 bagels and calculates that he spends an average of 90 cents per bagel. What is the value of x ?

- \$1.00
- \$1.40
- \$1.60
- \$2.20
- \$2.75

Question 12

A bookstore stocks $\frac{1}{5}$ of its books as fiction works, and $\frac{1}{3}$ less than the fiction books as self-help books. What fraction of the total books

- $\frac{3}{5}$
- $\frac{11}{30}$
- $\frac{4}{15}$
- $\frac{2}{15}$
- $\frac{1}{3}$

Question 13

Reservoir A contains 450 million gallons of water more than does Reservoir B. If 100 million gallons of water were to be drained from Reservoir A into Reservoir B, then Reservoir A would contain twice as much water as would Reservoir B. How many million gallons of water does Reservoir A currently contain?

- 500
- 600
- 700
- 800
- 900

DRILL 2

Question 1

The New Age Entertainment Company produces x mood rings at a cost, in cents, of $80x + 9,000$. These x mood rings can be sold for a price, in cents, of $260x$. What is the least value of x for which the New Age Entertainment Company does not lose money?

- 107
- 82
- 63
- 51
- 50

Question 2

Let S be a point on a circle whose center is R . If PQ is a chord that passes perpendicularly through the midpoint of RS , then the length of arc PSQ is what fraction of the circle's circumference?

- $\frac{1}{\pi}$
- $\frac{1}{3}$
- $\frac{\sqrt{3}}{\pi + 2}$
- $\frac{1}{2\sqrt{2}}$
- $\frac{2\sqrt{3}}{3\pi}$

Question 3

Assume that at a particular zoo, $\frac{2}{5}$ of all the animals are mammals, and $\frac{2}{3}$ of the mammals are allowed to interact directly with the public. If 24 mammals are allowed to interact directly with the public, how many animals in this zoo are NOT mammals?

- 36
- 48
- 54
- 60
- 72

Question 4

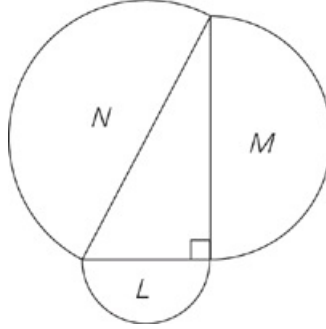

In the figure above, the letters L, M, and N denote the areas of the semicircular regions whose diameters are the sides of the triangle, as shown. What is the value of $\frac{L+M}{N}$

- $\frac{1}{2}$
- $\frac{\sqrt{2}}{2}$
- 1
- $\frac{\pi}{2\sqrt{2}}$
- $2\sqrt{2}$

Question 5

A square region has an area of b square inches and a perimeter of n inches. If $n = \frac{b}{3}$ what is the length, in inches, of the side of the square?

- 12
- $12\sqrt{2}$
- 48
- $48\sqrt{2}$
- 144

Question 6

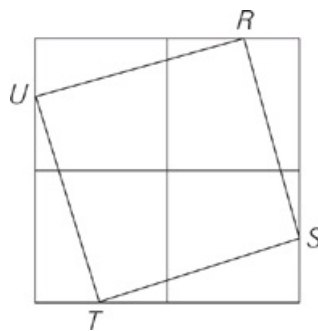

The figure above shows four adjacent small squares, forming one large square. The vertices of square RSTU are midpoints of the sides of the small squares. What is the ratio of the area of RSTU to the area of the large outer square?

- $\frac{1}{2}$

- $\frac{5}{9}$
- $\frac{7}{12}$
- $\frac{3}{5}$
- $\frac{5}{8}$

Question 7

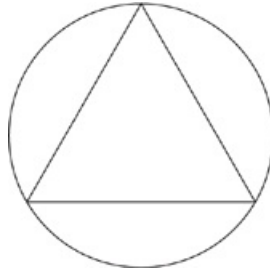

In the figure above, an equilateral triangle is inscribed in a circle. How many times greater is the area of the circle than the area of the triangle?

- $\frac{\pi}{\sqrt{3}}$
- $\frac{3\pi}{4}$
- $\frac{4\pi}{3\sqrt{3}}$
- 3
- $\frac{2\pi}{\sqrt{3}}$

Question 8

If $\frac{(x + 2)(x - 5)}{(x - 3)(x + 4)} = 1$, then $x =$

- 2
- $-\frac{1}{2}$
- 1
- $\frac{1}{2}$
- 2

Question 9

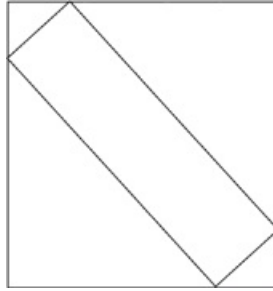

The figure above shows a rectangle inscribed within a square. How many times greater is the perimeter of the square than the perimeter of the inscribed rectangle?

- $\sqrt{2}$
- $\frac{2 + \sqrt{2}}{2}$
- 2
- $2\sqrt{2}$
- It cannot be determined from the information given.

Question 10

For which of the following values of x is $\frac{x^2}{4} + \frac{x}{2} - 4$ between 0 and 4?

- 1
- 2
- 3
- 4
- 5
- 6

Question 11

The New Gotham Department of Transit is taking an inventory of its vehicles. There are three times as many buses as train cars. 20 percent of the buses are powered by alternative fuels, of which 40 percent are powered by biofuels, 20 percent by hydrogen, and the remainder by natural gas. 25 percent of train cars are less than 5 years old, which is half the rate for natural gas buses. What percentage of New Gotham's vehicles are natural gas buses that are at least 5 years old?

Question 12

At Alex's Burger Palace, customers can purchase 2 veggie burgers and 2 shakes for \$6.50. Customers can also purchase 2 veggie burgers and 2 beef burgers for \$7.00. Which of the following could be accurate assignments of price to food item?

Indicate all possible values.

- veggie burger: \$2.25, shake: \$1.00
- veggie burger: \$2.25, beef burger: \$1.75
- veggie burger: \$2.00, shake: \$1.25
- beef burger: \$1.75, shake: \$1.25

- veggie burger: \$2.25, shake: \$1.25

Question 13

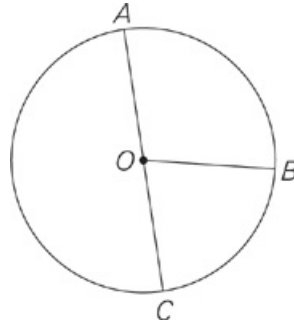

Note: Figure not drawn to scale

The radius of Circle Q is 8. If length of arc ABC is greater than 26, which of the following could be the value of the sums of angles AQB and BQC?

Indicate all possible values.

- 45°
- 60°
- 90°
- 150°
- 180°
- 240°
- 270°

DRILL 3

Question 1

Shares of XYZ Co and ABC Corp are sold on a stock exchange that closes at 5 p.m. each day. At the close of business on Monday, shares of XYZ Co sold for half the price of shares of ABC Corp. On Tuesday and Wednesday, the price of shares of XYZ Co decreased at a rate of $\frac{1}{5}$ per day. During that same period, shares of ABC Corp increased at a rate of $\frac{1}{4}$ per day. At the close of business on Wednesday, the price of shares of ABC Corp was how many times greater, rounded to the nearest integer, than the price of shares of XYZ Co?

Question 2

A model rocket takes off from an elevated launch pad 9 feet above the ground. The rocket's elevation follows the function $h = -2t^2 + 12t + 9$, where h represents the height after t seconds. Which of the following ordered pairs (t, h) could be the rocket's height at a given time?

Indicate all possible values.

- (1, 19)
- (2.5, 24.5)
- (3, 28)
- (4, 25)
- (5.5, 14.5)
- (6, 9)
- (7, 1)

Question 3

If $a + b = 15$ and $2a - b = 6$, what is the value of b ?

- 6
- 7
- 8
- 9
- 10

Question 4

If the perimeter of a rectangle is 24 and the length is twice the width, what is the length of the rectangle?

- 4
- 5
- 6
- 8

Question 5

Betty sold $\frac{3}{5}$ of her family's garage sale items. Ernest sold $\frac{1}{2}$ of the remaining items. What fraction of the family's garage sale items did Ernest sell?

$$\frac{\boxed{}}{\boxed{}}$$

Question 6

In Seattle, the total rainfall in a certain year was 37 inches. From April to October of that year, the average rainfall was approximately 1.7 inches per month. What was the average rainfall, in inches, for the remaining months of the year?

- 2
- 3.1
- 4
- 5
- 7.1

Question 7

In a certain game, players have three chances during each turn to earn points. Each consecutive win awards more points than the previous win. The second win awards 100 points more than the first, and the third win awards twice as many points as the second win. Tammy won the maximum number of points during her turn and received a total of 700 points. How many points are awarded for the first win?

- 50
- 75
- 100
- 200
- 400

Question 8

$$12x + 3 - (4 - 4x)$$

The above expression will equal an integer if x equals all of the following EXCEPT

Indicate all possible values.

- $-\frac{4}{3}$
- 0
- $\frac{3}{4}$
- $\frac{4}{3}$

Question 9

G is the sequence of numbers $g_1, g_2, g_3, \dots, g_n$ such that each term following the first is one more than two times the preceding term. If

$g_2 + g_4 = 30\frac{1}{2}$, what is the first term in the sequence?

$\frac{3}{4}$

1

$\frac{3}{2}$

$\frac{9}{4}$

$\frac{7}{2}$

Question 10

Nelson bowled 4 games and scored an average of 120 points. What score could he receive on his fifth game if he wants to have an overall average that is a multiple of 7, his favorite number?

Indicate all possible values.

80

110

155

185

Question 11

Wendy, Yvonne, and Elizabeth are baking cookies for a bake sale. Wendy can bake all of the cookies in 10 hours, Yvonne can bake half of the cookies in 3 hours, and Elizabeth can bake a third of the cookies in 5 hours. If Wendy and Elizabeth bake for 2 hours, how long will it take Yvonne to finish baking the rest of the cookies?

1.8

2

3

3.6

4

Question 12

Mark has twice as many oranges as George. Tony has 10 less than twice the sum of George and Mark's oranges. If Tony were to give 15 oranges to George and 5 oranges to Mark, George and Mark would each have half the number of oranges Tony had originally. How many oranges did George have originally?

10

15

20

25

50

Question 13

www.ZTCprep.com

Katherine drank 25 percent of her bottle of soda on the way to work, and drank another 3 ounces when she got there. The bottle now

contains 60 percent of what it contained originally. How many ounces of soda did Katherine's bottle originally hold?

- 4
- 8
- 10
- 16
- 20

ANSWERS

Drill 1

1. D
2. A
3. D
4. A
5. D
6. D
7. D
8. B
9. C
10. D
11. A
12. E
13. B

Drill 2

1. E
2. B
3. C
4. C
5. A
6. E
7. C
8. D
9. A
10. D
11. 3
12. A, C, D
13. F, G

Drill 3

1. 5
2. A, D, E, F
3. C
4. D
5. $1/5$
6. D
7. C
8. A, D
9. D
10. A, D
11. E
12. A
13. E

Drill 1

1. D The minute you see the phrase “what value of d,” list the answer choices on your scratch paper and label the first column. In this case, the answer choices, (Column 1) represent the price of a new release, d . If you assume choice (C) to be the correct answer, a new release costs \$5.25. That means that a standard release (Column 2) costs \$2.25. Carl rented two new releases for five days (Column 3), at a cost of \$50.50 ($2[\$5.25 + (4)\$5.00]$). His standard release cost him \$9 (Column 4), for a total of \$59.50. It’s too low, so the initial price of the DVD must be too low. Cross off choices (C), (B) and (A). You now have instructions for exactly what to do with each of the remaining answer choices. Start with \$6 and follow the exact same process. The answer is choice (D).
2. A The problem wants you to figure out “five less than five times the number.” When the question asks for “the number,” plug in the answers and work backwards. Start with choice (C) and carefully work through the problem, one step at a time. Remember to write out the steps on your scratch paper to make things easier to follow. Choice (C) is -5 . This number is “5 less” than “5 times the number,” so first add 5 to -5 . That yields 0. 0, then, is “5 times the number” you’re looking for. The only number you can multiply by 5 to get 0 is 0 itself, so that’s the number you want. But does 0 work in the problem? No, because “three less than two times” 0 is just $2(0) - 3$, or -3 . This doesn’t equal “two more than three times the number,” which is $3(0) + 2$, or 2. For a problem like this, it’s tough to figure out if you need a bigger or smaller number, so just pick one and go. Try choice (A), which is -30 . -30 is 5 less than the number you want, so you need to add 5. That gives you -25 . And -25 is five times the number you’re looking for, so what number times 5 yields -25 ? It’s -5 (because $5 \times -5 = -25$, so -25 is five times -5). Now check -5 in the first part of the question. $2(-5) - 3 = -13$. And $3(-5) + 2$ is also -13 , so they’re equal and the best answer is choice (A).
3. D Plug in each of the answer choices to see which value cannot work. If 1 goal for 3 points is scored, then the team scored 45 points on unassisted goals (because the team had 48 points and 1 goal was worth 3 points, that leaves $48 - 3 = 45$) To score 45 points, the team would need 9 assisted goals (9 goals at 5 points each gives us $9 \times 5 = 45$), so choice (A) cannot be correct. If 6 goals for 3 points are scored, then there are 18 points scored on unassisted goals and 30 points remain to be accounted for. 30 points can be achieved by 6 goals scored with assistance, so choice (B) cannot be correct. If 11 goals for 3 points are scored, there are 33 points scored and 15 left over, so that equals 3 goals scored without assistance, making choice (C) incorrect. If 12 goals for 3 points are scored, then 36 points have been scored and there are 12 points remaining. This is not divisible by 5, so choice (D) does not work and is the correct answer.
4. A List your answer choices in a column on your scratch paper and label it “Shirley’s hourly.” Assume Shirley’s hourly is \$25; Melinda’s hourly (Column 2), therefore, must be twice that, or \$50. Shirley worked at that rate for 1.75 hours and earned \$43.76 (Column 3). Melinda worked for $\frac{3}{4}$ of an hour and earned \$37.50 (Column 4). The two together, therefore, earned \$81.25 (Column 5), which is almost double what it should be. Cross off choices (C), (D), and (E) and try jumping to Choice (A). Choice (A) is the correct answer.
5. D As soon as you see the phrase “how much” write your answer choices in a column and label it “Cost to the School” (Column 1). If the \$120 the school pitched in represents $\frac{1}{5}$ of the cost of the trip, then the trip must have cost \$600 (Column 2). Subtract \$20 for the processing fee, then 10% for the discount, then add the processing fee back on. This gives you the actual cost of \$542 (Column 3) and the students a surplus of \$58 (Column 4). Subtract the \$18 they had left over and divide the rest by 200; this will give you the price per cookie (Column 5), \$0.80. This is way too much per cookie. To pay less per cookie you need to have more left over, so the school must have chipped in more money. Cross off choices (C), (B), and (A). Don’t be afraid of lots of columns. Combining steps means that you are doing work in your head, and this is where mistakes happen. Keep each step simple and methodical. Limit yourself to one operation per step. This will help prevent errors. Plug \$160 into your new spreadsheet. It works. You’re done.
6. D

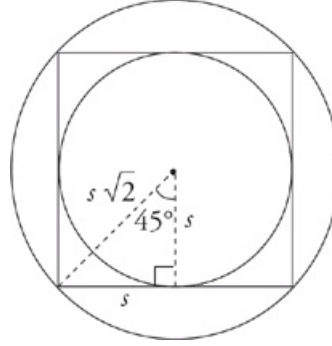

There are two important things to notice about this problem. The first is that it contains no values whatsoever. The second is that it asks for a ratio, which is just a special type of fraction. A fraction question with missing numbers equals a hidden Plug In. Plug in a number for the radius of the smaller circle—say 2. If the radius of the smaller circle is equal to 2, then the area of the smaller circle is 4π . To find the area of the larger circle, make a right triangle. The legs of the triangle are 2 each and the diagonal is $2\sqrt{2}$. This is equal to the radius of the larger circle, which therefore has an area of $(2\sqrt{2})^2\pi$, or 8π . The ratio of these two numbers is equal to 2.

7. D The question wants the total amount of tips, so try Plugging In the Answers. In choice (D), if the total earned in tips was \$120, then the 4 waiters combined receive $\frac{2}{3}$ of \$120, or \$80. The manager receives $\frac{1}{4}$ of \$120, or \$30, and the busboy receives the remaining \$10. Because 4 waiters received \$80, and 1 waiter received \$20, 1 waiter and the busboy together receive \$30.
8. B Don't attempt messy algebra if you can avoid it! The question wants to know the value of x , and it must be one of the answers provided. So just plug in the answers. Normally, you'd start with choice (C), but that's a messy radical, so start with choice (B) instead. Plug in 0 for x and you get $\sqrt{0+3} = \sqrt{0} + \sqrt{3}$. These two are equal, so choice (B) is the answer.
9. C This is another question on which you can avoid algebra by simply Plugging In the Answers. The question asks for the value of m , so see which of the choices works in the problem. Start with choice (C), which is $\frac{3}{2}$. The problem states that $mn = 9$, so that means $\frac{3n}{2} = 9$. Solve for n , you get 6. Now you just have to make sure that $\frac{n}{m} = 4$. It does, because $\frac{6}{\frac{3}{2}} = 6 \times \frac{2}{3}$, which is 4. Thus, choice (C) is the answer.
10. D A percent question with no specific values indicates a hidden Plug In question. The question mentions "the original price," but gives no actual number, so assume that the original price of the garment was \$100. After the first reduction, the sale price was $100 - (20\% \text{ of } 100) = \80 . After the second reduction, the final price was $80 - (10\% \text{ of } 80) = \72 . The total reduction from the original price was therefore \$28, which is 28% of the original price. Choice (D) is the answer.
11. A When you see, "What is the value of x ," you know what to do. The answers (Column 1) represent the price of a bagel. If one bagel costs \$1.60, then 56 bagels would cost \$89.60 (Column 2). Fortunately there is a discount of \$1.40 per dozen, so the total discount is \$5.60 (Column 3). The actual price paid, therefore, is \$84 (Column 4) or an average of \$1.50 per bagel (Column 5). This is too much, so cross off Choices (C), (D), and (E). It's too much by a lot, so try choice (A). It works.
12. E This is another hidden Plug In problem. It asks for a fraction of an unknown total, so just make up your own number. Plug in 15 for the total. So $\frac{1}{5}$ of 15 = 3 fiction books. Then $\frac{1}{3}$ of 3 is 1, so there's 1 fewer self-help than fiction, or $3 - 1 = 2$ self-help books. Together, there are $3 + 2 = 5$ fiction and self-help books out of 15 total books so $\frac{5}{15} = \frac{1}{3}$.
13. B This algebra problem has numbers in the answers, so solve it by Plugging In the Answers. Start with choice (C): If Reservoir A contains 700 million gallons of water, then Reservoir B has 450 million gallons less, or 250 million gallons. When 100 million gallons are drained from Reservoir A to Reservoir B, then the reservoirs will hold 600 million and 350 million gallons of water, respectively. That's not the relationship you're looking for—Reservoir A should have twice the water as Reservoir B—so eliminate choice (C). Try choice (B): If Reservoir A contains 600 million gallons of water, then Reservoir B has 450 million gallons less, or 150 million gallons. When 100 million gallons are drained from Reservoir A to Reservoir B, then the reservoirs will hold, respectively, 500 million and 250 million gallons of water. That's the relationship you're looking for—Reservoir A has twice as much water as Reservoir B—so select choice (B).

- E The problem asks for the least value of x . Instead of doing the messy algebra, simply plug in the answers. The question asks for the least value, so start with the smallest value given and work your way up. Start with choice (E). If x equals 50, then the cost is $80(50) + 9,000$, which is 13,000. The money made from the sale of the rings is $260(50)$, or 13,000. The problem says the company must not lose money (which is not the same as making money), so choice (E) is correct.
- B

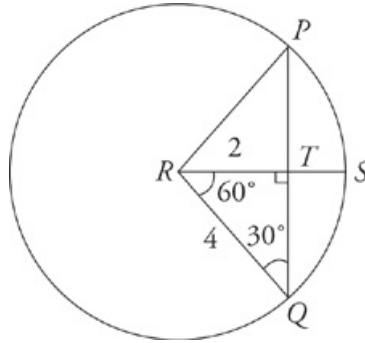

Make sure to draw the picture first. The question asks for a fraction, so plug in any numbers you want, as long as they make sense with the problem. Make the radius of the circle 4. That means that RQ and RP are both equal to 4. RS is also 4, because it is a radius as well. The problem states that a line goes through the midpoint of RS , so RT must be 2. Now you have a right triangle with leg 2 and hypotenuse 4. If you use the Pythagorean theorem to find the third side, it will be $2\sqrt{3}$. Thus, you have 30-60-90 triangles for RTQ and RTP . This means angle R is 120 degrees and the arc is $\frac{1}{3}$ of the circumference. Thus, choice (B) is correct.

- C This problem is a bit tricky because at first it looks like a hidden Plug In. The question does not tell you the number of animals in the zoo and gives you a bunch of fractions. But, in fact, this is a Plugging In the Answers problem, because the question asks for the total number of non-mammals in the zoo and the answer choices are real numbers, not fractions or percents. Start by Plugging In choice (C), 54, for the number of non-mammals. Now, use the information in the problem to find the number of mammals. According to the problem, 24 mammals are allowed to interact with the public, and this is $\frac{2}{3}$ of all the mammals. Thus, there must be 36 total mammals in the zoo (because 24 is $\frac{2}{3}$ of 36). If there are 36 mammals and 54 non-mammals, then there are 90 animals in the zoo. Now, check this number against the information in the problem. The problem says that $\frac{2}{5}$ of all the animals are mammals and 36 is $\frac{2}{5}$ of 90. Choice (C) is the correct answer.

- C

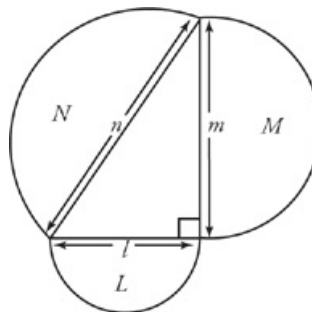

Don't be intimidated by the lack of numbers in the problem—that just means you can Plug In. The question asks for a fraction, so any numbers that you plug in will work, provided they make sense in the problem. The triangle is a right triangle, so use some familiar numbers for the legs: 6, 8, and 10. If l is 6, then the radius of the semicircle is 3 and the area is 4.5π (remember, it's half of a circle, so you need to take half of the area). Similarly, m is 8, so the radius of the circle is 4 and the area of the semicircle is 8π . Lastly, n is 10, which means the radius is 5 and the area is 12.5π . If you add $L + M$, you get 12.5π . If you put this over N , you get a fraction equal to one, which is choice (C).

5. A This problem is a great opportunity to plug in the answers: For any given side, simply find b (the area, or the square of the side) and n (the perimeter, or 4 times the length of the side), and then determine whether they meet the given condition of $n = \frac{b}{3}$. Only choice (A) will give the desired results. If the side of the square is 12, then $b = 144$, $n = 48$, and $48 = \frac{144}{3}$.

6. E

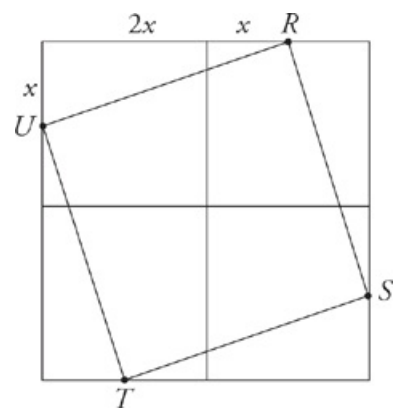

Remember, a ratio is just another type of fraction. No numbers are provided, so plug in anything you want and see what happens. Make the side of each smaller square 4. To find the area of the square in the middle, you need the length of one of its sides. Get this by using the Pythagorean theorem. You have a right triangle formed by the length of one smaller square plus half of the length of the adjacent square (because points R, S, T, and U are all midpoints according to the problem). So if the length of a side of a smaller square is 4, you have a triangle with legs 6 and 2. By the Pythagorean theorem, the hypotenuse is $\sqrt{40}$. This is the length of one of the sides of the square in the middle. The area of this inner square is therefore 40, which is $\sqrt{40}$ squared. The area of the big square is going to be 64, or 8 squared. The ratio of areas is $\frac{40}{64}$, which is equal to $\frac{5}{8}$, which is choice (E).

7. C

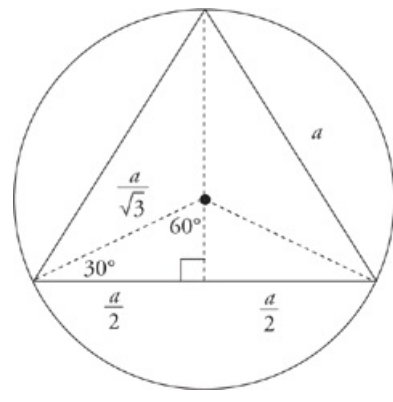

Don't attempt this problem without Plugging In some numbers. The problem wants to know "how many times" greater is the area of the circle than the area of the triangle. This is same as asking what the ratio of the two areas is. A ratio is a fraction, so plug in numbers and work from there. Make each side of the equilateral triangle 6. To find the area of the triangle, draw in the height to create a 30-60-90 triangle with base 6 and height $\sqrt{3}$. These values yield an area of $9\sqrt{3}$ for the triangle. To find the radius, draw lines from the center of the circle to each vertex of the triangle. Thus, you have created two smaller 30-60-90 triangles. The side opposite the 60 degree angle is equal to 3, so the hypotenuse of the smaller triangle is twice the length of the side opposite the 30 degree angle. This shorter side is equal to $\frac{3}{\sqrt{3}}$ (to move from the medium side of a 30-60-90 triangle to the shortest side, divide by $\sqrt{3}$). The hypotenuse of the triangle is twice this value, or $\frac{6}{\sqrt{3}}$. This is equal to the radius of the circle, so the area of the circle is $\pi \frac{6}{\sqrt{3}}$ squared or 12π . Finally, the ratio of the areas is $\frac{12\pi}{9\sqrt{3}}$. This reduces down to choice (C).

8. D Plug in the values in the answer choices and see which one works. Start with choice (C), which is 1. That makes the top of the fraction $(3)(-4)$ and the bottom $(-2)(5)$. This doesn't equal 1. Try choice (D). The top of the fraction becomes $(2.5)(-4.5)$ and the bottom becomes $(-2.5)(4.5)$. This does equal 1, so choice (D) is correct.

9. A

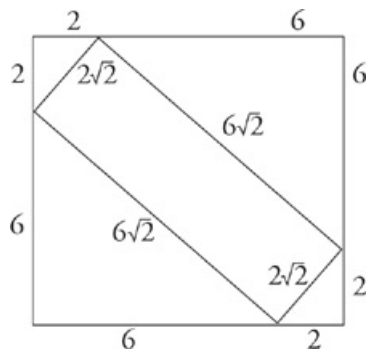

This problem is another hidden Plug In. There are no numbers provided and the question asks for the ratio of the perimeters, so plug in your own numbers according to the ratio you've been given. Make the length of the side of the square 8. Assume the sides of the small triangles in the corners are 2. That leaves 6 for the length of the rest of the side. The sides of the rectangle are the hypotenuses of the right triangles. The smaller right triangle is 2 by 2, so the hypotenuse is $2\sqrt{2}$. The larger triangles are 6 by 6, so the hypotenuses are $6\sqrt{2}$. Now, you just need to add up the sides to get the perimeters. The square is simply $8 + 8 + 8 + 8$, which equals 32. The rectangle is $2\sqrt{2} + 2\sqrt{2} + 6\sqrt{2} + 6\sqrt{2}$. This simplifies to $16\sqrt{2}$. 32 is $\sqrt{2}$ times greater than $16\sqrt{2}$, making choice (A) correct.

10. D An algebraic equation and numbers for answer choices mean Plugging In the Answers, so start by listing out your answer choices. Try

numbers near the middle first: If $x = 3$, then $\frac{3^2}{4} + \frac{3}{2} - 4 = \frac{9}{4} + \frac{6}{4} - \frac{16}{4} = -\frac{1}{4}$; eliminate choice (C). Since choice (C) was too small, so

are answer choices (A) and (B)—although it'll only take a moment to verify if you're not sure. Try choice (D) next: If $x = 4$, then

$\frac{4^2}{4} + \frac{4}{2} - 4 = 4 + 2 - 4 = 2$; so choice (D) is one of the correct answer choices. Keep going: If $x = 5$, then

$\frac{5^2}{4} + \frac{5}{2} - 4 = \frac{25}{4} + \frac{10}{4} - \frac{16}{4} = \frac{19}{4} = 4\frac{3}{4}$. That's too big, so eliminate choice (E)—and with it choice (F) as well. Only choice (D) works.

11. 3 To solve this question, try Plugging In. Since the question is asking about a percentage, it is a Hidden Plug In, and—unless there's a

compelling reason not to—you should try 100. If there are 100 vehicles, then there are 75 buses and 25 train cars. Since 20% of 75 =

$\frac{20}{100} \times 75 = 15$, you know 15 buses use alternative fuels; of those 15, 40% use biofuels, so $\frac{40}{100} \times 15 = 6$ use biofuels, and 20% use

hydrogen, so $\frac{20}{100} \times 15 = 3$ use hydrogen. That leaves 6 that use natural gas. The number of train cars younger than 5 years old is 25%;

that rate is half the rate for natural gas buses, so 50% of natural gas buses are less than 5 years old. 50% of 6 is 3, so 3 natural gas buses are less than 5 years old, and 3 are at least 5 years old. Finally, the question asks for what percentage of vehicles are natural gas buses at least 5 years old, which is 3 out of 100, or 3 percent.

12. A, C, and D

To solve this question, plug in the answers. Choice (A) works: If the veggie burger costs \$2.25 and the shake costs \$1.50, then $2(\$2.25) + 2(\$1.00) = \$6.50$. Choice (B) does not work, since 2 veggie burgers and 2 beef burgers cost \$7.00, but $2(\$2.25) + 2(\$1.75) = \$8.00$. Eliminate choice (B). Choice (C) works, since 2 veggie burgers and 2 shakes cost \$6.50, and $2(\$2.00) + 2(\$1.25) = \$6.50$. Choice (D) works: If 2 veggie burgers and 2 beef burgers cost \$7.00, and beef burgers cost \$1.75, then $2(\text{veggie}) + 2(\$1.75) = \7.00 , and veggie burgers cost \$2.00. This works with the other equation, since 2 veggie burgers and 2 shakes cost \$6.50, and $2(\$2.00) + 2(\$1.25) = \$6.50$. Finally, choice (E) does not work, since 2 veggie burgers and 2 shakes cost \$6.50, but $2(\$2.25) + 2(\$1.25) = \$7.00$. Eliminate choice (E), and you're left with choices (A), (C), and (D).

12. F and G

Plug in the answers. Normally, you'd start with one of the middle answer choices, but choice (E) looks easiest to solve. It's half the circle; the circumference of the whole circle would be 16π , which can be approximated to about 50 using your on-screen calculator.

Half the circle, then, would be about 25. Since the length of the arc is greater than 26, choice (E) is too small, as are choices (A), (B), (C), and (D). Eliminate them all. Choice (F) makes the sum of the angles represent $\frac{240}{360}$, or $\frac{2}{3}$, of the whole circle; $\frac{2}{3}$ of about 50 is easily greater than 26, so choice (F) works, as does choice (G).

1. 5 To solve this question, Plug In. Here, the “hidden” variable is the starting share price of either stock. A nice number to plug in will be divisible by 2, 4, and 5, such as 400. If XYZ Co sold on Monday for \$400, then ABC Corp sold for \$800. To calculate the price of XYZ Co on the next 2 days, $\frac{1}{5}$ of 400 is 80, so the price on Tuesday was $\$400 - \$80 = \$320$; $\frac{1}{5}$ of 320 is 64, so the price at the close of business on Wednesday was $\$320 - \$64 = \$256$. For ABC Corp, $\frac{1}{4}$ of 800 is 200, so the price on Tuesday was $\$800 + \$200 = \$1000$; $\frac{1}{4}$ of 1000 is 250, so the price at the close of business on Wednesday was $\$1000 + \$250 = \$1250$. Finally, divide the final price of ABC Corp by that of XYZ Co: $1250 \div 256$ equals about 4.88, which rounds to 5.
2. A, D, E, and F
To solve this question, try Plugging In the Answers. For answer (A), if you plug $t = 1$ into the function, then $h = 19$, so choice (A) works. If $t = 2.5$, though, then $h = 26.5$, so eliminate choice (B). If $t = 3$, then $h = 27$, so eliminate choice (C). If $t = 4$, then $h = 25$, so choice (D) works. If $t = 5.5$, then $h = 14.5$, so choice (E) works. If $t = 6$, then $h = 9$, so choice (F) works. If $t = 7$, finally, then $h = -5$, which does not equal 1, so eliminate choice (G). Choices (A), (D), (E), and (F) are correct.
3. C Although you could solve the system of equations, it is easier and more reliable to plug in the answers. Since it is the middle value of this range of answers, begin by plugging in choice (C). If $b = 8$, then a must be equal to 7. Then, plug that into the second equation: $2 \times 7 = 14$. $14 - 8 = 6$, which is what it was supposed to equal. The answer is choice (C).
4. D Use Plugging In the Answers. Start with choice (C): If the length is 6, then the width is 3, and the perimeter is 18. That’s too small, so eliminate choices (A), (B), and (C). Go to choice (D). If the length of the rectangle is 8, then the width is 4, and the perimeter is 24. That matches the information from the question, so there’s no need for you to check choice (E).
5. $\frac{1}{5}$ Plug in a number for the original number of garage sale items that works with the fractions in the problem. It’s often easiest to multiply the denominators of all of the fractions in the problem. So let’s say there are 10 items. That means that Betty sold 6, and Ernest sold half of 4, or 2. The question asked for the fraction of items Ernest sold, and you solved for the number he sold. That’s okay, because all you have to do is put that number over the total number of items, 10. So, Ernest sold $\frac{2}{10}$, or $\frac{1}{5}$.
6. D Simplify this question by using Average Pies to deal with the two steps of the problem. First, use the pie on the left to figure out how many total inches of rain fell in the 7 months from April to October; you’ll get 11.9, which you can round up to 12. Next, subtract that total from 37 to find out how many remaining inches fell during the other 5 months. Finally, take those remaining 25 inches and divide by the remaining five months—as shown in the Average Pie on the right—and you’ll have choice (D).

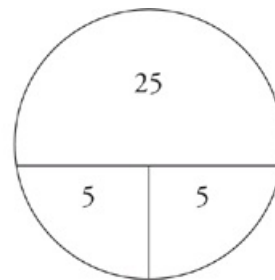
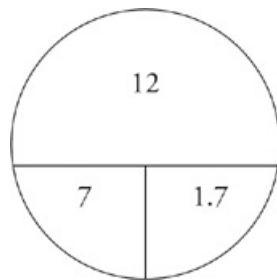

7. C With actual values in the answer choices, this question is a good example of when to use PITA. Set up columns with the first, second, and third wins labeled at the top. The correct answer should have the three amounts totaling 700. When you work through choice (C), you’ll see that it works—which means there’s no need to try any others.

1 st win	2 nd win	3 rd win	TOTAL
50			
75			
100	200	400	700
200			
400			

If you simplify the expression you get $16x - 1$. Now, plug in each of the answer choices. Choices (B) and (C) yield integer values, but choices (A) and (D) don't. This is an interesting new feature of the new question types: Normally the EXCEPT/NOT/LEAST questions will have only one answer that doesn't work. With ATA (All That Apply) questions, you can have multiple answers that don't work. Be careful!

9. D It's an algebra question with numbers for answer choices, so set up your scratch paper to Plug In the Answers. Start with choice (C); if

the first term is $\frac{3}{2}$, then one more than twice the previous term is 4, so that's g_2 . The sequence becomes easy to compute from there:

$g_3 = 4 \times 2 + 1 = 9$; $g_4 = 9 \times 2 + 1 = 19$; and $g_2 + g_4 = 4 + 19 = 23$. That's too small, so eliminate choices (C), (B), and (A).

Between choices (D) and (E), it's easier to double choice (E), so try that next: If $g_1 = \frac{7}{2}$, then $g_2 = 8$, $g_3 = 17$, and $g_4 = 35$; now g_2

$+ g_4 = 8 + 35 = 41$. This is too big, so eliminate choice (E) and select choice (D).

10. A and D

First, use an Average Pie. Multiply 4 by 120 and you have a total of 480 points for the first 4 games. Now, use PITA to figure out which answers will work to give you an average that is divisible by 7. Start with choice (A), because on click-all-that-apply questions, there's no reason to start in the middle if many answers might work. $480 + 80 = 560$. $560 \div 5 = 112$. That is divisible by 7. How about choice (B)? $480 + 110 = 590$. $590 \div 5 = 118$. Is that divisible by 7? No. Keep working until you've checked each answer. Choices (A) and (D) are the only ones that work.

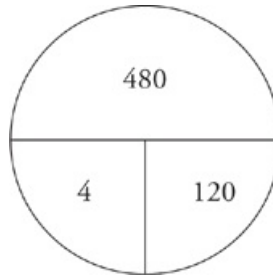

11. E Plug in for the number of cookies. Choose a number that's divisible by all the numbers in the question, such as 30. That means that Wendy's rate is 3 cookies per hour. Now, be careful with Yvonne and Elizabeth's rates. Yvonne can bake 15 cookies in 3 hours, or 5 per hour. Elizabeth can bake 10 cookies in 5 hours, or 2 per hour. If Wendy and Elizabeth bake together, they can make a total of 5 cookies in one hour. If they bake for 2 hours, they'll bake 10 cookies. For Yvonne to finish the baking on her own, she'll need to bake the 20 remaining cookies. At a rate of 5 cookies per hour, it will take her 4 hours to finish the job, so choice (E) is the answer.

12. A Use PITA here. If you start with choice (C), George has 20 oranges, which means Mark has 40 and Tony has 110. If we add 15 to George, he'd have 35, and Mark would get 5, so he'd have 45. These values aren't equal—in fact, the difference between them is too large, so that's a clue that we should try using smaller numbers. If you try choice (B), Mark now has 30, Tony has 80, and after Tony gives 15 to George and 5 to Mark, George has 30 and Mark has 35. The difference is smaller, so we know we are going in the right direction. The answer must be choice (A). If you try choice (A), George has 10, Mark has 20, and Tony has 50 to start. After the exchange, George and Mark both have 25, which is half of 50.

13. E You have numbers in the answers and a missing variable in the question, so plug in the answers as shown below. You'd normally start with choice (C), but 10 isn't divisible by 4, so move onto a different number. If you recognize that choice (D) is too small, so you can eliminate choices (A), (B), and (C) as well, and the answer must be choice (E). If not, try it: Take away 5 ounces, or 25%, and then another three, and you're left with 12 ounces, which is 60% of 20.

Original	-25%	-3	% of original
4			
8			
10	yucky!		
16	12	9	56.25% — too small
20	15	12	60%



Number Properties

NUMBER PROPERTIES

The math section on the GRE is as much a test of reading comprehension as it is a test of math. Many of the problems you will see involve pieces of information given to you in prose format. Good readers read quickly and holistically, reading for overall meaning but not necessarily reading every word. This is how most of you were trained. Unfortunately, this method does not work so well on the GRE when you are under time pressure, you're reading off a screen (not a printed page), and every word counts. When you are reading math problems, mouth the words to yourself and use your finger or your pencil to track the text on the screen. It may feel silly, but it will protect you from the reading errors that are inevitable on a four-hour test.

MATH VOCABULARY

You must also know your math vocabulary. Your ability to get the correct answer on many questions will rest entirely on your knowledge of key math terms. If you have a question that states, "Set A consists of consecutive, single digit, non-negative, even integers," you will have one answer choice that contains 0 and one that does not. Which one is correct? Is zero positive or negative? Is it odd or even? Is it an integer? In order to maximize your score, you must know your math vocabulary.

Here is a list of common math terms tested on the GRE.

Term	Definition	Examples
Integer	a "whole" number that does not contain decimals, fractions, or radicals; can be positive, negative, or zero	-500, 0, 1, 28
Positive	greater than zero	0.5, 25, $\frac{5}{3}$
Negative	less than zero	-72.3, $-\frac{7}{4}$, -2
Even	an integer divisible by two	-40, 0, 2
Odd	an integer not divisible by two	-41, 1, 3
Divisible	when a number divides into another number with nothing leftover	10 is divisible by 2, but not by 3.
Remainder	the "leftovers" when one number doesn't divide evenly into another number	When 10 is divided by 3, the remainder is 1.
Divisor	a number that divides into another number	In the statement "24 divided by 6," 6 is the divisor.
Sum	the result of adding	The sum of 3 and 4 is 7.
Difference	the result of subtracting	The difference between 7 and 2 is 5.
Product	the result of multiplying	The product of 5 and 7 is 35.
Quotient	the result of dividing	The quotient of 8 and 2 is 4.
Prime	a number that is only divisible by itself and 1; 1 is not considered prime (because 1 is itself); negative numbers and zero are not prime	2, 3, 5, 7
Consecutive	in a row, usually ascending	1, 2, 3, 4; -3, -2, -1, 0
Digits	0-9; the numbers on the phone pad	1, 2, 3, 4, 5, 6, 7, 8, 9, 0
Distinct	different	2 and 3 are distinct; 6.25 and 6.26 are distinct; 4 and 4 are not distinct.

(Click [here](#) to view a larger image.)

CALCULATING

For any GRE problem without a variable, you can always calculate the answer. In fact, ETS will always give you that option. You will be able to calculate your way to the answer, but it will take you 1-2 minutes and increase your opportunity for error tenfold. Instead, look for shortcuts. Remember the GRE is a test of thinking, not of calculating. Here are some shortcuts that will help expedite your thinking.

negative × negative = positive
positive × positive = positive
negative × positive = negative
even × even = even
odd × odd = odd
even × odd = even
even + or - even = even
odd + or - odd = even
even + or - odd = odd

If you have these rules memorized, you won't have to try out examples to figure out the problem; you will have the answer in a matter of moments with nary a need to calculate. This is powerful.

Divisibility is another area where you can use shortcuts. You will rarely need to know exactly how many times one number can be divided by another. Often, all you need to know is whether one number can be divided by another.

Rules of Divisibility

A number is divisible by	Rule	Examples
2	It's even (i.e., its last digit is even).	1,57 <u>6</u> ✓
3	Its digits add up to a multiple of 3.	8,532 $8 + 5 + 3 + 2 = 18$ ✓
4	Its last two digits are divisible by 4.	121, <u>532</u> $32 \div 4 = 8$ ✓
5	Its last digit is 5 or 0.	568,74 <u>5</u> ✓ 32 <u>0</u> ✓
6	Apply the rules of 2 and 3.	55,740 It's even and $5 + 5 + 7 + 4 + 0 = 21$ ✓ ✓
8	Its last three digits are divisible by 8.	345,862, <u>120</u> $120 \div 8 = 15$ ✓
9	Its digits add up to a multiple of 9.	235,692 $2 + 3 + 5 + 6 + 9 + 2 = 27$ ✓
10	Its last digit is zero.	11,13 <u>0</u> ✓
12	Apply the rules of 3 and 4.	3,552 $3 + 5 + 5 + 2 = 15$ and $52 \div 4 = 13$ ✓ ✓

Occasionally you will see questions that seem to relate to rules of divisibility but that involve numbers too big to calculate. For example, try this question.

Which of the following numbers will divide evenly into 12^{11} : 24, 36, 2^{11} , 2^{22} , 3^{11} , 3^{12} , 40, or 48^2 ?

Clearly, you are not going to calculate each of these answer choices. Therefore, when in doubt, expand it out, but do so using prime factors. Think of the question as a fraction that you will reduce. On the top you have $(2 \times 2 \times 3)$ 11 times. The first answer choice, 24, can be broken down into $(2 \times 2 \times 2 \times 3)$. You can cancel each one of the numbers on the bottom of the fraction with the equivalent numbers on the top, so 24 will divide evenly into 12^{11} . Now try the other 7 answer choices.

36

Yes. You can cancel out two 2's and two 3's. No problem.

2^{11}

Yes. You will have more than eleven 2's on the top that you can cancel with the 2's on the bottom. No problem.

2^{22}

Yes. There are two 2's in every group on the top of the fraction and you have 11 groups. That means you will have twenty-two 2's on the top and twenty-two 2's on the bottom. They will cancel out.

3^{11}

Yes. You will have eleven 3's on the top and eleven 3's on the bottom. They will cancel out.

3^{12}

Nope, you will be one 3 short. You will have eleven 3's on the top of the fraction, but twelve on the bottom. It won't work.

40

Nope. 40 breaks down to $2 \times 2 \times 2 \times 5$. The 2's will cancel out, but there's no 5 on the top to cancel with the 5 on the bottom.

Yes, 48 breaks down to $2^4 \times 3$. When you square that you get $2^8 \times 3^2$. There are enough 2's and 3's on the top to cancel with the 2's and 3's on the bottom.

$$\frac{12^{11}}{48^2} = \frac{2^{22} \times 3^{11}}{2^8 \times 3^2} = \frac{\cancel{2 \times 2 \times 2 \times 2 \times 2 \times 2 \times 2 \times 2 \times 2 \times 2 \times 2} \times \cancel{3 \times 3} \times 3 \times 3 \times 3 \times 3 \times 3 \times 3 \times 3 \times 3 \times 3}{\cancel{2 \times 2 \times 2 \times 2 \times 2 \times 2 \times 2 \times 2} \times \cancel{3 \times 3}}$$

When you have a division problem with numbers too big to calculate, use prime factors to figure out how many times one number will divide evenly into the other.

ABSOLUTE VALUE

Simply put, absolute value is the distance from zero on a number line. It doesn't matter if you are moving in a positive direction or a negative one. Absolute value tends to show up on Quant Comp questions, because it's easy to confuse positive and negative numbers. Just remember to plug in both positive and negative numbers when you have a variable inside absolute value brackets.

PEMDAS

The GRE will test the order of operations, and there will be a wrong answer choice waiting for you if you get the order wrong.

Here's how it works.

P|E|M D|A S

- P stands for "parentheses." Solve for your parentheses first.
- E stands for "exponents." Solve for your exponents next.
- M stands for "multiplication" and D stands for "division." The arrow is meant to indicate that you do all your multiplication and division together in the same step, going from left to right.
- A stands for "addition" and S stands for "subtraction." Again, as the arrow indicates, you do all your addition and subtraction together in the same step, going from left to right.

For more practice and a more in-depth look at The Princeton Review math techniques, check out our student-friendly guidebook, *Cracking the New GRE*.

DRILL 1

Question 1

3 and 5 are factors of x .

Quantity A

The remainder when x is divided by 10

Quantity B

6

- Quantity A is greater.
- Quantity B is greater.
- The two quantities are equal.
- The relationship cannot be determined from the information given.

Question 2

$$\frac{5 \times 5}{5 + 5} + \frac{5 \times 5}{5 + 5} =$$

- 1
- $\frac{5}{4}$
- 2
- $\frac{5}{2}$
- 5

Question 3

$$|1 - 5| = |5 - m|$$

Quantity A

m

Quantity B

4

- Quantity A is greater.
- Quantity B is greater.
- The two quantities are equal.
- The relationship cannot be determined from the information given.

Question 4

x , y , and z are consecutive even integers.

Quantity A

xy

Quantity B

yz

- Quantity A is greater.
- Quantity B is greater.

- The two quantities are equal.
- The relationship cannot be determined from the information given.

Question 5

If $bc \neq 0$, and $3b + 2c = 18$, then which of the following is NOT a possible value of c ?

- $5\frac{3}{5}$
- 6
- $8\frac{2}{5}$
- 9
- 12

Question 6

At the local grocery store, apples normally cost 40 cents each. During a recent sale, the price was reduced to 3 apples for a dollar. How much money would be saved by purchasing 30 apples at the sale price?

- \$1
- \$1.50
- \$2
- \$2.50
- \$3

Question 7

$$y < 0$$

Quantity A

$$2y$$

Quantity B

$$20y$$

- Quantity A is greater.
- Quantity B is greater.
- The two quantities are equal.
- The relationship cannot be determined from the information given.

Question 8

Which of the following could be the difference between two positive integers whose product is 28?

- 1
- 3
- 4
- 7
- 14

Set X consists of the positive multiples of 5, and set Y consists of the odd prime numbers less than 20. If set Z consists of every distinct integer less than 100 that is the product of one element from set X and one element from set Y, then set Z consists of how many elements?

- 12
 14
 15
 16
 18

Question 10

$$\frac{u}{v} \left(\frac{x}{y+z} \right)$$

If the value of the expression above is to be doubled by halving exactly one of the five variables, which variable should be halved?

- u
 v
 x
 y
 z

Question 11

$$m > 0, n > 0$$

Quantity A

$$\frac{m}{mn}$$

Quantity B

$$\frac{n}{mn}$$

- Quantity A is greater.
 Quantity B is greater.
 The two quantities are equal.
 The relationship cannot be determined from the information given.

Question 12

Which of the following is the best approximation of $\sqrt{\frac{(98.763)(0.49)^2}{(0.252)}}$?

- $\frac{1}{4}$
 $\frac{1}{2}$
 5
 10

Question 13

Quantity A

Quantity B

Three times the sum of the prime numbers less than 10

The sum of the prime numbers between 20 and 30

- Quantity A is greater.
- Quantity B is greater.
- The two quantities are equal.
- The relationship cannot be determined from the information given.

Question 14

Tasha's favorite number can be written as $3^2 \times 17^2$.

Quantity A

Quantity B

The number of distinct positive divisors of Tasha's favorite number

9

- Quantity A is greater.
- Quantity B is greater.
- The two quantities are equal.
- The relationship cannot be determined from the information given.

DRILL 2

Question 1

If x is a positive integer greater than 1, which of the following has the greatest value?

- $\frac{1}{x}$
- $\frac{1}{x+1}$
- $\frac{x}{x+1}$
- $\frac{x}{\left(\frac{1}{x+1}\right)}$
- $\frac{x}{\left(\frac{x}{x+1}\right)}$

Question 2

Which of the following CANNOT be the sum of two prime integers?

- 7
- 19
- 23
- 31
- 43

Question 3

If r is an integer multiple of 8, then which of the following could NOT be divisible by r ?

- 216
- 384
- 360
- 416
- 420

Question 4

If x , y , and z are consecutive even integers, such that $x < y < z$ and $xyz = 960$, what is the value of z ?

Question 5

Which of the following integers has both 12 and 17 as factors?

- 34

- 120
- 204
- 217

Question 6

f , g , and h are consecutive prime numbers such that $f < g < h$.

Quantity A

$$f + g + h$$

Quantity B

$$3g$$

- Quantity A is greater.
- Quantity B is greater.
- The two quantities are equal.
- The relationship cannot be determined from the information given.

Question 7

How many positive integers less than 20 are factors of 96?

- 5
- 6
- 7
- 8
- 9

Question 8

If p and q are both positive odd integers, which of the following must be odd?

Indicate all possible values.

- pq
- $2pq$
- $3pq$
- $pq + p^q$
- $p^q + q^p$

Question 9

If a and b are integers, $ab = -5$, and $a - b > 0$, which of the following must be true?

- I. $a > -1$
- II. b is odd
- III. $|a| = 5$

- I only
- II only

- I and III only
- I, II, and III

Question 10

$$y = |y|$$

$$y = -|y|$$

Quantity A

y

Quantity B

0

- Quantity A is greater.
- Quantity B is greater.
- The two quantities are equal.
- The relationship cannot be determined from the information given.

Question 11

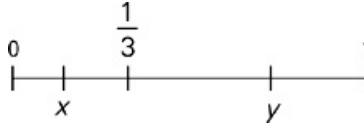

If x and y are letters which correspond to points on the number line shown above, which of the following statements must be true?

- $x > y$
- $\frac{1}{x} < \frac{1}{y}$
- $\frac{1}{x} \times \frac{1}{y} > 9$
- $xy < \frac{1}{3}$
- $x + y > 1$

Question 12

n is a positive integer.

The remainder when $5n$ is divided by 4 is 3.

Quantity A

The remainder when $10n$ is divided by 4

Quantity B

2

- Quantity A is greater.
- Quantity B is greater.
- The two quantities are equal.
- The relationship cannot be determined from the information given.

Question 13

Quantity A

ab

Quantity B

$a + b$

- Quantity A is greater.
- Quantity B is greater.
- The two quantities are equal.
- The relationship cannot be determined from the information given.

DRILL 3

Question 1

When the number of people in an office is divided by 12, the remainder is 0. If $\frac{3}{2}$ times the number of people in the office is divided by 12, and the remainder resulting from this operation is greater than 0, the remainder must be

- 1
- 2
- 3
- 5
- 6

Question 2

a, b, and c are multiples of 15 and $a < b < c$

Quantity A

The remainder when b is divided by c

Quantity B

The remainder when (b + c) is divided by a

- Quantity A is greater.
- Quantity B is greater.
- The two quantities are equal.
- The relationship cannot be determined from the information given.

Question 3

Emma is 3 years older than Merrick, who is 8 years younger than Aliza. If Aliza is at least 25, which of the following could be Emma's age?

Indicate all possible values.

- 12
- 15
- 17
- 20
- 25
- 29

Question 4

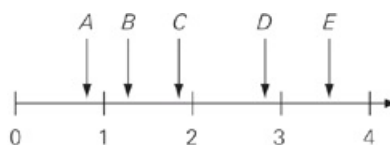

Note: Figure drawn to scale.

www.ZTCprep.com If each letter on the number line above is the number that corresponds to the point below it, then which of the following is closest to

D ÷ A?

- A
- B
- C
- D
- E

Question 5

Set X consists of all the even integers from 1 to 100, inclusive, and set Y consists of all the integers divisible by 5 from 1 to 100, exclusive. How many members of set X are not members of set Y?

Question 6

If negative integer a is multiplied by b and the result is greater than 0 but less than $|a|$, then which of the following must be true of b ?

- $b > 1$
- $0 < b < 1$
- $-1 < b < 0$
- $b < a$
- $|b| < a$

Question 7

A number divisible by a positive even prime number must be

- prime
- odd
- even
- the square of a prime
- the square of an odd number

Question 8

What are the greatest and smallest positive differences between any of the factors of 210?

- 103 and 1
- 209 and 0
- 210 and 1
- 103 and 11
- 209 and 1

Question 9

On Monday, Janice started training for a marathon and ran one mile that day. On Tuesday, Janice ran one mile more than she did on Monday. She continues this training process for 12 days. The sum of the total number of miles Janice ran has how many distinct prime



Question 10

Last year, Melania had a total of \$20,000 invested in two mutual funds, Capital Growth Fund and Venture Index Fund. At the end of the year, she analyzed her investments and found that her earnings on her shares of Capital Growth Fund were three times half of her earnings on her investment in Venture Index Fund. If she earned a total of \$1,250 on her investments in the two funds, and had three times as much money invested in Capital Growth Fund as in Venture Index Fund, what percent interest did Melania earn on her investment in Venture Index Fund? (percent interest = $\left(\frac{\text{earnings}}{\text{investment}}\right) \times 100$)

- .075
- .01
- 7.5
- 10
- 500

Question 11

a is the product of 3 and the square root of 2, b is the product of 2 and the square root of 3, and c is the product of 2 and the square root of 6. If x is the square of the sum of a and b , y is the product of 6 and the difference of 5 and c , and z is the product of 2 squared and 3 squared, what is $\frac{xy}{z}$?

- 1
- $30 - 12\sqrt{6}$
- 36
- $30 + 12\sqrt{6}$
- 64

Question 12

The integer m is a multiple of 154, 250, and 264. Which of the following do NOT have to be factors of m ?

Indicate all possible values.

- 176
- 242
- 275
- 924
- 2,500
- 7,000

Question 13

When p is divided by z , the result is y remainder q , then which of the following must be true?

- $z(y + q) = x$
- $\frac{x}{z} - y = \frac{q}{z}$
- $xz - q = y$
- $\frac{x}{z} = y + q$
- $\frac{x}{z} = yz + q$

DRILL 4

Question 1

If $x^a y^b z^c$ equals the product of 154 and 56, $z > y > x$, and $a > b > c$, then what is the value of $a^x b^y c^z$?

- 1,024
- 2,048
- 8,624
- 22,528
- It cannot be determined from the information given.

Question 2

If $|-3x + 1| < 7$, then which of the following represents all possible values of x ?

- $-2 < x$
- $-2 < x < \frac{8}{3}$
- $-2 \leq x \leq \frac{8}{3}$
- $x < -2$, or $x > \frac{8}{3}$
- $x \leq -2$, or $x \geq \frac{8}{3}$

Question 3

What is the smallest common multiple of 160 and 240?

Question 4

When x is divided by 3, the remainder is 1. When x is divided by 7, the remainder is 2. How many positive integers less than 100 could be values for x ?

Question 5

If j is a multiple of 12, and k is a multiple of 21, then jk must be a multiple of which of the following?

- 8
- 15
- 22
- 28
- 35

Question 6

$$\frac{xz}{y} = 420$$

In the equation above, x is an integer with 3 distinct prime factors, and y is a positive integer with no prime factors. If z is a positive, non-prime number, what is one possible value of z ?

Question 7

If w is a non-positive integer, which of the following must be positive?

Indicate all possible values.

- $-3w$
- $2w + 10$
- w^4
- w^0
- $-w + 0.5$

Question 8

Integers a and b are consecutive multiples of 6. Integers x and y are consecutive multiples of 8. In terms of a , b , x , and y , what is the ratio of the average of a and b and the average of x and y ?

- $\frac{x + y}{a + b}$
- $\frac{a + b}{x + y}$
- $\frac{a + \frac{b}{4}}{y - \frac{x}{4}}$
- $\frac{a + \frac{b}{4}}{y - \frac{x}{2}}$
- $\frac{\frac{1}{2}(a + b)}{x + y}$

Question 9

If $|x^2y| = |(-w)z|$, then which of the following could be true?

Indicate all possible values.

- $x^2 = wz$
- $|x^2y| = |(-w)z|$
- $-(wz) = wz$
- $| -x^2 | = |(-w)z|$
- $-w = z$

$x^2 = -|y|$

Question 10

If p and x are non-negative numbers and y is a non-positive number, then which of the following must be true?

Indicate all possible values.

$px > xy$

$px > 0$

$pxy > -1$

$pxy \leq 0$

$px \neq y$

$x \geq py$

Question 11

If $\frac{2}{3^x} < 0.02$, what is the least integer value of x ?

No such least value exists.

101

100

5

4

Question 12

If x is divisible by 78, which of the following must be divisible by x ?

Indicate all possible values.

$\frac{x}{78}$

x

$x + 78$

$\frac{78}{x}$

$78 - x$

$78x$

$78x + 78$

Question 13

$$\frac{210^2 \times 21^3 \times 49^{\frac{1}{2}}}{30^4 \times 3} = 7^x, x =$$

ANSWERS

Drill 1

1. B
2. E
3. D
4. D
5. D
6. C
7. A
8. B
9. B
10. B
11. D
12. D
13. B
14. C

Drill 2

1. D
2. C
3. E
4. 12
5. D
6. D
7. D
8. E
9. C
10. C
11. D
12. C
13. D

Drill 3

1. E
2. A
3. D, E, F
4. E
5. 41
6. C
7. C
8. E
9. 3
10. D
11. A
12. A, B, E
13. B

Drill 4

1. B
2. B
3. 480
4. 4
5. D
6. 4, 6, 10, 14
7. D, E
8. D
9. A, C, D, E
10. D, F
11. D
12. B, F
13. 6

Drill 1

1. B Plug in a value that meets the given requirements; try $x = 15$. The remainder when 15 is divided by 10 is 5; Quantity B is greater, so eliminate choices (A) and (C). Any acceptable value of x gives the same outcome, so select choice (B).
2. E Find the value of each fraction by multiplying the numbers in the numerator and adding the numbers in the denominator. The value of each fraction is $\frac{25}{10} = \frac{5}{2}$. Add the two fractions: $\frac{5}{2} + \frac{5}{2} = \frac{10}{2} = 5$.
3. D Solve for m . If $|1 - 5| = |5 - m|$, then $|-4| = |5 - m|$, or $4 = |5 - m|$. When you see absolute values, remember to consider both positive and negative solutions: $5 - m = 4$ or $5 - m = -4$, so m can equal 1 or 9, leaving you with choice (D) for the answer.
4. D Try Plugging In; one set of values that could work is $x = -2$, $y = 0$, and $z = 2$. In this case, both Quantity A and Quantity B have a value of 0. Eliminate choices (A) and (B). However, another set of values that could work is $x = -6$, $y = -4$, and $z = -2$. With this set of values, Quantity A has a value of 24 and Quantity B has a value of 8. Eliminate choice (C). You are left with choice (D) for the answer.
5. D This problem offers a good opportunity to plug in the answers—for simplicity's sake, start with the integers. If $c = 6$, choice (B), then $3b + 2(6) = 18$, so $3b + 12 = 18$, $3b = 6$, and $b = 2$. The only other requirement given is that $bc \neq 0$, so 6 is, in fact, a possible value of c . If $c = 9$, as in choice (D), then $3b + 2(9) = 18$, so $3b + 18 = 18$, $3b = 0$, and $b = 0$. A value of 0 for b would violate the given requirement, so 9 is NOT a possible value of c .
6. C 30 apples at 40 cents apiece cost \$12. Buying 30 apples at 3 per dollar would cost \$10. Therefore, the sale price is \$2 less than the normal price.
7. A When $y = -1$, Quantity A is -2 and Quantity B is -20 . Eliminate choices (B) and (C). Plug in another value for y . When $y = -100$, Quantity A is -200 and Quantity B is $-2,000$. Quantity A is always greater.
8. B The two positive integers must have a product of 28, so find the factor pairs of 28: 1 and 28, 2 and 14, and 4 and 7. Only choice (B) gives a possible difference: $7 - 4 = 3$.
9. B Solve this problem by brute force, but be systematic about it. Set Y has a finite number of elements, so list them out and start finding the products when those elements are multiplied by positive multiples of 5. Set $Y = \{3, 5, 7, 11, 13, 17, 19\}$, so multiplying by 5—the first positive multiple of 5—yields 15, 25, 35, 55, 65, 85, and 95; that's 7 elements for set Z thus far. Multiplying by 10—the next positive integer multiple of 5—yields 3 more products, 30, 50, and 70. Multiplying by 15 yields two new products, 45 and 75; multiplying by 20 yields only one new product, 60. That's a total of 13 elements for set Z so far. You already have 75 as a member of set Z, so multiplying by 25 yields no new products; multiplying by 30 yields the final new product, 90. Set Z thus consists of 14 elements: set $Z = \{15, 25, 30, 35, 45, 50, 55, 60, 65, 70, 75, 85, 90, 95\}$. If you got choice (E), you may have mistakenly included 2 as an element of set Y.
10. B Plug in values for the variables, such as $u = 2$, $v = 4$, $x = 6$, $y = 8$, and $z = 10$. With these values, the expression equals $\frac{1}{6}$. Try halving each of the values to find which one would change the value of the expression to $\frac{1}{3}$. Halving v to 2 works; the answer is choice (B).
11. D Time to Plug In! If you make $m = 2$ and $n = 3$, then Quantity A becomes $\frac{2}{2 \times 3} = \frac{1}{3}$, and Quantity B becomes $\frac{3}{2 \times 3} = \frac{1}{2}$. Quantity B is bigger; eliminate choices (A) and (C). However, if you make $m = 3$ and $n = 2$, then the situation is reversed: Quantity A will be $\frac{1}{2}$, and Quantity B will be $\frac{1}{3}$. Eliminate choice (B); the answer must be choice (D).
12. D Try rounding your values before you calculate. The expression can be estimated as

$$\sqrt{\frac{(100)\left(\frac{1}{2}\right)^2}{\left(\frac{1}{4}\right)}} = \sqrt{\frac{100\left(\frac{1}{4}\right)}{\left(\frac{1}{4}\right)}} = \sqrt{\frac{25}{\left(\frac{1}{4}\right)}} = \sqrt{25 \times \frac{4}{1}} = \sqrt{100} = 10.$$
13. B The prime numbers less than 10 are 2, 3, 5, and 7—don't forget, 1 is not prime. Their sum is 17, and $3 \times 17 = 51$. The only prime numbers between 20 and 30 are 23 and 29, and their sum is 52. Quantity B is greater.
14. C It is easier to work with the factors of Tasha's favorite number, rather than with the number itself. Write out the number as $3 \times 3 \times$

17×17 and make a list of the divisors—or factors—in pairs. The pairs are: 1 and $3 \times 3 \times 17 \times 17$, 3 and $3 \times 17 \times 17$, 17 and $3 \times 3 \times 17$, 3×3 and 17×17 , and 3×17 and 3×17 . The final pair contains only one distinct factor, giving you a total of 9 factors.

1. D Try Plugging In on this one. If $x = 4$, then choice (A) is $\frac{1}{4}$ or 0.25, choice (B) is $\frac{1}{5}$ or 0.2, choice (C) is $\frac{4}{5}$ or 0.8, choice (D) is $\frac{4}{1} = 4 + \frac{1}{5} = 4 \times 5 = 20$, and choice (E) is $\frac{4}{4} = 4 \div \frac{4}{5} = 4 \times \frac{5}{4} = 5$. Choice (D) is the greatest.
2. C Rather than listing out all of the prime numbers up to 43, stay focused on the unique number, 2, the only even prime number. All of the choices are odd, and two odd numbers would yield an even sum, so you'll only be able to eliminate answers by adding 2 to an odd number. Each of the incorrect answers, therefore, is the sum of 2 and the previous prime number: Choice (A) is $2 + 5$; choice (B) is $2 + 17$; choice (D) is $2 + 29$; and choice (E) is $2 + 41$. The answer is choice (C).
3. E Plug in a value for r : The first integer multiple of 8 is 8 itself. Only choice (E) fails to yield an integer: $\frac{420}{8} = 52.5$.
4. 12 Ballpark that 960 is about 1,000, which is $10 \times 10 \times 10$. Then test a set of consecutive even integers near 10, such as $10 \times 12 \times 14 = 1,680$. This product is too large. Try $8 \times 10 \times 12 = 960$, giving you $z = 12$.
5. D Eliminate choices (A) and (E) because they are not divisible by 12. Eliminate choices (B) and (C) because they are not divisible by 17.
6. D The intervals between consecutive prime numbers does not follow a consistent, predictable pattern. Prove it by Plugging In: Try $f = 2$, $g = 3$, and $h = 5$. Now $f + g + h = 10$ and $3g = 9$. Quantity A is greater; eliminate choices (B) and (C). Now try $f = 7$, $g = 11$, and $h = 13$. This time, $f + g + h = 31$, and $3g = 33$. Quantity B is now greater. Eliminate choice (A), and you're left with choice (D).
7. D The factors of 96 are 1, 2, 3, 4, 6, 8, 12, 16, 24, 32, 48, and 96. Eight of these numbers are less than 20.
8. A and C
As soon as you see variables in the answer choices, set up your scratch paper to Plug In. Start with easy numbers like $p = 3$ and $q = 5$, and eliminate any answer choice that doesn't yield an odd result. Choice (A) is 15, so keep it. Choice (B) is 30, so eliminate choice (B). Choice (C) is 45, so keep it. Choice (D) is 258, and Choice (E) is 368, so you can eliminate both; if you recognize them as the sum of two odd numbers, you don't have to calculate either of them. It's a must be problem, so try another set of numbers in choices (A) and (C) to be sure; as long as p and q are both positive odd integers, choices (A) and (C) will always work.
9. C If a and b are integers with a product of -5 , then there are only 4 options: $a = 5$ and $b = -1$; $a = -5$ and $b = 1$; $a = 1$ and $b = -5$; and $a = -1$ and $b = 5$. The requirement that $a - b > 0$ eliminates the second and fourth options, leaving only $a = 5$ and $b = -1$ and $a = 1$ and $b = -5$. (I) and (II) are both true for these two cases and (III) is not true if $a = 1$, making choice (C) the answer.
10. C The first equation tells you that y cannot be a negative number. The second equation tells you that y cannot be a positive number. Therefore, y must be 0.
11. D Plug in values for x and y that fit the figure: Try $x = \frac{1}{6}$ and $\frac{2}{3}$. Now, plug these numbers into each of the choices and use POE. Only choice (D) is correct: $\frac{1}{6} \times \frac{2}{3} = \frac{2}{18} = \frac{1}{9}$, which is less than $\frac{1}{3}$.
12. C If the remainder is 3, then $5n$ must be 3 more than a multiple of 4, such as 4, 8, 12, or 16. Try adding 3 to these multiples to find a possible value for $5n$. $12 + 3$ yields 15 as a value for $5n$; $n = 3$. Quantity A is the remainder when 30 is divided by 4, or 2. Eliminate choices (A) and (B). Try a different number. If n is 7, then $5n$ is 35, which also has a remainder of 3 when divided by 4. In Quantity A, 70 divided by 4 has a remainder of 2. For any other numbers you try, choice (C) will be the answer.
13. D Plug in values for a and b . If $a = -2$ and $b = 2$, then Quantity B is greater. Eliminate choices (A) and (C). If $\frac{1}{2}$ and $b = \frac{1}{4}$, then Quantity A is greater. Eliminate choice (B).

1. E Plug in 12 for the number of people in the office, because the remainder is 0 when 12 is divided by 12. Because $\frac{3}{2} \times 12$ is 18, and the remainder when 18 is divided by 12 is 6, choice (E) must be correct.
2. A Try Plugging In. If $a = 15$, $b = 30$, and $c = 60$, Quantity A is 30 because c cannot divide into b even one time. Quantity B is 0 because 90 divided by 15 has no remainder. Eliminate choices (B) and (C). Try a new set of numbers to further narrow your choices. If $a = 30$, $b = 45$, and $c = 120$, Quantity A is 45, and Quantity B is 15. The answer is choice (A).
3. D, E, and F
It's an algebra question with numbers for answer choices, so set up your scratch paper to plug in the answers. Start with choice (C): If Emma is 17, then Merrick is 14, and Aliza is 22. That's too young, so eliminate choices (A), (B), and (C). Now try choice (D): If Emma is 20, then Merrick is 17, and Aliza is 25. That's old enough, so select choices (D), (E), and (F).
4. E Estimate that D is approximately 2.8 and A is approximately 0.8. So the answer is $2.8 \div 0.8$, or 3.5, which is closest to choice (E).
5. 41 Half of the integers from 1 to 100—inclusive—are even, so set X has 50 members. Set Y has 19 members, the integers divisible by 5 from 1 to 100 exclusive, so don't include 100. Of the 19 members of set Y, 9 are even and therefore, in set X. The 50 members of set X minus the 9 members that are also in set Y yields $50 - 9 = 41$ members.
6. C To solve this problem, Plug In for a and b , but don't forget your restrictions. If $a = -4$, then a value of $-\frac{1}{2}$ for b would yield a product greater than 0 but less than $|a|$. Only choice (C) works.
7. C The only number that is positive, even, and prime is 2. Because the number is divisible by 2, it must be even.
8. E First, list all of the factors of 210. The easiest way to do this is in pairs, starting with 1 and 210 (remember, the number itself is considered one of its factors). Count up from one and check to see if each number you count is a factor of 210.
- 1 and 210
2 and 105
3 and 70
5 and 42
7 and 30
10 and 21
14 and 15

When you reach 14, you'll see that you'll just repeat 15 and 14 if you keep counting, so you know you're finished. The question asked for the greatest and smallest positive difference between any two factors. (It's helpful that the question specified positive difference so you know you don't need to count negative differences, though once you look at the answer choices you can see that's not what the question is asking for). The way you listed the factors makes this easy because as you look down the list, the difference between factors decreases. So the greatest difference is between 210 and 1, and the smallest difference is between 14 and 15. The final answer is 209 and 1.

9. 3 Adding the numbers together won't take long, but there is a shortcut to this problem. Match up the smallest number of miles (1) with the largest number of miles (12), and then the second smallest (2) with the second largest (11), etc. until all the numbers are matched up.
- 1 12
2 11
3 10
4 9
5 8
6 7

The sum of each of these 6 pairs is 13, which means you could multiply 13 by $6 = 78$ to get the total number of miles. Next, find the prime factors of 78. We already know it's divisible by 13 and 6 (because we had multiplied those together to get 78). Given that 13 is prime, you now need to find the prime factors of 6, which are 2 and 3. All together we have 3 prime factors at the bottom of the prime factor tree, so that's our answer.

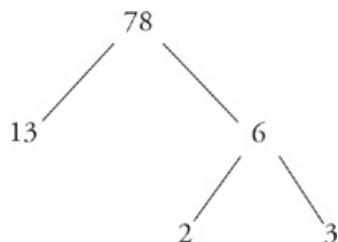

10. D Start by translating her earnings on her shares of Capital Growth Fund were three times half of her earnings on her investment in Venture Index Fund from English to math. Represent her earnings in Capital Growth Fund as C. Were translates to “ = .” Three times half is “ $3 \times \frac{1}{2}$,” and of is “ \times ” (multiplication). Represent Melania’s earnings from Venture Index Fund as V, and the resulting equation is $C = \frac{3}{2}V$. Total earnings on the two funds were \$1,250, so $C + V = \$1,250$, and since $C = \frac{3}{2}V$, that equation can be rewritten as $\frac{3}{2}V + V = \$1,250$, or $\frac{5}{2}V = \$1,250$. Solve this to find that $V = \$500$ earned on Venture Index Fund. Notice that this is a partial answer that is included among the answer choices. Continuing to solve, represent the amount of money invested in Venture Index Fund as x. Melania had three times as much money invested in Capital Growth Fund as in Venture Index Fund; therefore she had $3x$ dollars invested in Capital Growth Fund. She had a total of \$20,000 invested in the two funds; therefore $3x + x = \$20,000$. Solve to find that $x = \$5,000$ invested in Venture Index Fund. Now, plug in those numbers to the percent interest formula given in the problem, $\left(\frac{500}{5000}\right) \times 100$, which equals the credited answer, choice (D), 10. You will arrive at the remaining, wrong answer choices if you mistakenly solve for the percent interest earned on Capital Growth Fund, and/or you represent your answer as a multiplier, rather than a percent (i.e., 0.01 versus 10%).

11. A Let’s translate this question, one step at a time.

$$a = 3\sqrt{2} \quad b = 2\sqrt{3} \quad c = 2\sqrt{6}$$

$$x = (3\sqrt{2} + 2\sqrt{3})^2 = (3\sqrt{2} + 2\sqrt{3})(3\sqrt{2} + 2\sqrt{3}) =$$

$$(9)(2) + 6\sqrt{6} + 6\sqrt{6} + (4)(3) = 18 + 12\sqrt{6} + 12 + 12 = 30 + 12\sqrt{6}$$

$$y = 6(5 - 2\sqrt{6}) = 30 - 12\sqrt{6}$$

$$z = 2^2 \times 3^2 = 6^2 = 36$$

$$\frac{xy}{z} = \frac{(30 + 12\sqrt{6})(30 - 12\sqrt{6})}{36} = \frac{900 + 360\sqrt{6} - 144(6)}{36} = \frac{900 - 864}{36} = \frac{36}{36} = 1$$

Did you recognize the common quadratics? The product of x and y in the last chunk of the question contains one that could save you that intermediary step: $(x + y)(x - y) = x^2 - y^2$. Of course, it doesn’t take too much longer to write out the math.

12. A, B, and E

To solve this question, turn large numbers into small numbers by working with factors. The prime factors of 154 are 2, 7, and 11; the prime factors of 264 are 2, 2, 2, 3, and 11; and the prime factors of 250 are 2, 5, 5, and 5. The only numbers that must be a factor of m are those made up of factors contained in the other three numbers. You can’t recount factors that overlap in the different numbers, so you know that m is made up of, at least, three 2’s, one 3, three 5’s, one 7, and one 11. Now check the answers. The prime factors of 176 are 2, 2, 2, 2, and 11, which is one 2 too many, so choice (A) is not a factor; since the question asks you to identify which choices are not factors, choice (A) is part of the credited response. The prime factors of 242 are 2, 11, and 11, which is one 11 too many, so (B) is also not a factor. The prime factors of 275 are 5, 5, and 11, so choice (C) is a factor. The prime factors of 924 are 2, 2, 3, 7, and 11, so choice (D) is a factor. The prime factors of 2,500 are 2, 2, 5, 5, 5, and 5, which is one 5 too many, so choice (E) is not a factor. And, finally, the prime factors of 7,000 are 2, 2, 2, 5, 5, 5, and 7, so choice (F) is a factor. The correct answers are choices (A), (B), and (E).

13. B As soon as you see variables in the answer choices, set up your scratch paper to Plug In. If $x = 16$ and $z = 5$, then $16 \div 5 = 3$ remainder 1, so $y = 3$ and $q = 1$. Plug your values into the answer choices, and only choice (B) works: $\frac{16}{5} - 3 = \frac{1}{5}$.

- B To solve this question, find the prime factors: The prime factors of 154 are 2, 7, and 11, and the prime factors of 56 are 2, 2, 2, and 7. Thus, the product of 154 and 56 will have the prime factors 2, 2, 2, 2, 7, 7, and 11, or $(2^4)(7^2)(11^1)$. Line up your bases and exponents with the inequalities, and you get $a = 4$, $b = 2$, and $c = 1$ for the bases, and $x = 2$, $y = 7$, $z = 11$ for the exponents. Now $a^x b^y c^z = (4^2)(2^7)(11^1)$, which equals $16 \times 128 \times 1$, or 2,048. The correct answer is choice (B).
- B You can Plug In or solve on this problem. To Plug In, choose a value that fits one of the answer choices, such as $x = 2$, which would fit in the range for choice (C). If $x = 2$, then $|-3x + 1| = 5$, which is true, so we can eliminate any answer choice that doesn't include $x = 2$: choices (A), (D), and (E). Logically, it doesn't make sense that an inequality with a $<$ sign would have a \leq sign when it's been solved, but to be sure, check $x = -2$. In that case, $|-3x + 1| = 7$, and is not < 7 , so the answer must be choice (B). If you solve this problem, remember that you have to solve both $-3x + 1 < 7$, and $-3x + 1 > 7$. Also remember that you must flip the sign any time you multiply or divide both sides of an inequality by a negative number.
- 480 Make lists of the multiples for each number. Work on 240 first, then list the multiples of 160 until you find one on the list for 240.

240:	160:
240	160
480	320
720	480
960	

- 4 To solve this question, write it out. Since there are fewer numbers that yield a remainder of 2 when divided by 7, start there. The first such number is 2, and thereafter they increase by 7; the rest of the list is thus 9, 16, 23, 30, 37, 44, 51, 58, 65, 72, 79, 86, and 93. Rather than list out all the numbers that yield a remainder of 1 when divided by 3, just select the numbers that meet the requirement from the list you already have: Only 16, 37, 58, and 79 do, so there are 4 values for x .
- D Plug in values for j and k . Since every number is a multiple of itself, go ahead and start with $j = 12$ and $k = 21$; jk is now 252. You can use your on-screen calculator to determine that, of the answer choices, only 28 divides evenly into 252. Choice (D) is correct.
- 4, 6, 10, and 14
Don't forget that you can use your on-screen calculator. There's only one positive integer with no prime factors, the number 1. Therefore, $y = 1$, and $xz = 420$. Create a prime factor tree to get the prime factors of 420: 2, 2, 3, 5, and 7. Pick 3 distinct values from that list, such as 2, 3, and 5, and multiply them to find one possible value of x . One example is $2 \times 3 \times 5 = 30$, or one possible value for x . If $30z = 420$, then $z = 14$. Confirm that 14 is not prime, then enter it in the field. If you chose 2, 3, 7, then x is 42 and z is 10 and also correct, and so on.
- D and E
Remember to Plug In multiple times for must be questions. First, use an easy number, such as -1 , and try it in each choice:

	$w = -1$
$-3w$	3
$2w + 10$	8
w^4	1
w^0	1
$-w + 0.5$	1.5

All of the answers are positive, so don't eliminate anything. Can we eliminate anything by making w smaller? A number such as -10 will allow us to eliminate choice (B), but everything else is still positive. But can $w = 0$? Non-positive just means the number can't be positive—it doesn't mean it can't be zero.

	$w = 0$
$-3w$	0
$2w + 10$	10
w^4	0
w^0	1
$-w + 0.5$	0.5

- D You should Plug In on this question. Variables a and b can be consecutive numbers such as 6 and 12. Plug in consecutive multiples of 8 for x and y , such as 8 and 16. Finding the ratio of the averages is easy now; the averages of each pair of numbers will be the halfway point between the two numbers. For 6 and 12, the average is 9. For 8 and 16, the average is 12. The ratio of these averages is

$\frac{3}{4}$. Now, plug your original numbers into the answer choices and look for the one that equals $\frac{3}{4}$. Choice (A) gives you $\frac{4}{3}$ which is the reciprocal of what you want. Cross it off. Choice (B) gives you $\frac{3}{4}$ which is what you're looking for. But don't stop yet—keep checking all of the answers. Choice (D) also works with these numbers. No harm done, just try a different set of numbers and check the two remaining choices. Plug in some really unusual numbers, like 24 and 30 for a and b, and 80 and 88 for x and y. Now you are looking for an answer to give you $\frac{9}{28}$. Choice (B) no longer works, so choice (D) is your answer.

9. A, C, D, and E

The best way to approach a could be question is to consider many different kinds of numbers to plug in that could work in the problem. We will have to plug in a few times here, so let's start with easy numbers. For instance, let's try making every variable in the problem equal to 1. Immediately, choices (A) and (D) work. If we made $w = 1$ and $z = -1$, then choice (E) works as well. Try plugging in 0 for either w or z and choice (C) can also work. In the end, choices (B) and (F) are always going to have a positive value on the left side of the equation and a negative value on the right, and therefore will not be correct. An absolute value is always positive, so it can never equal something negative.

10. D and F

As soon as you see variables in the answer choices, set up your scratch paper to Plug In. Start with easy numbers like $p = 2$, $x = 3$, and $y = -4$. Of the answer choices, all work except choice (C), which can be eliminated. Now plug in different numbers: Since the variables are described as non-negative and non-positive, try making p, x, and y all 0. Now choices (A), (B), and (D) all yield false statements and can be eliminated. The correct answers are choices (D) and (F).

11. D First, rewrite 0.02 as a fraction, $\frac{2}{100}$. For $\frac{2}{3^x}$ to be less than $\frac{2}{100}$, $3x$ must be greater than 100. Plugging In the Answers is the easiest

way to get this right. Choice (E) is $3^4 = 81$ and the fraction is greater than 0.02; eliminate it. Choice (D) is $3^5 = 243$ and this makes the fraction less than 0.02. Therefore, the least value for x is 5. Be sure to answer what is asked. The inequality would be true if the denominator of $\frac{2}{3^x}$ were 101, which is choice (B); however, the question is asking for the least value of x, not of 3^x , so the correct answer is choice (D).

12. B and F

There are variables in the answer choices, so Plug In. Try $x = 78$. You can eliminate choices (A) and (D). Now try a weird number: 0. Eliminate choice (G). Try one more number: 156, which is double 78. This time you can eliminate choices (C) and (E). A number is divisible by itself and a multiple of a number is divisible by that number, so the correct answers are choices (B) and (F).

13. 6 Break down the left side of the equation into prime factors to make it easier to simplify. You should get

$$\frac{(3^2 \times 7^2 \times 2^2 \times 5^2) \times (3^3 \times 7^3) \times 7}{(2^4 \times 5^4 \times 3^4) \times 3} = 7^x$$

Then group all the like terms:

$$\frac{2^4 \times 3^5 \times 5^4 \times 7^6}{2^4 \times 3^5 \times 5^4} = 7^x$$

Everything cancels out on the left side except for 7^6 , which makes 6 your answer.



Fractions, Decimals,
and Percentages

FRACTIONS

You will see plenty of fractions on the GRE, but don't worry; everything you need to know about them you learned in second grade. You must be able to add, subtract, multiply, divide, and compare fractions. Here are the basics, with a couple of neat tricks thrown in.

Adding

In grade school, you learned to find the lowest common denominator. That still works. The Bowtie method is a convenient way to find the common denominator.

It looks like this.

$$10 = \frac{2}{3} + \frac{4}{5} = 12 = \frac{10}{15} + \frac{12}{15} = \frac{22}{15}$$

Just multiply across the bottom to get your common denominator. Multiply on the diagonal to figure out your numerators and then add across the top. It works the same way for subtracting.

$$\frac{3}{8} - \frac{1}{5} = \frac{15}{40} - \frac{8}{40} = \frac{7}{40}$$

Here's another helpful tip. If you have a fraction with addition or subtraction in the numerator, and a single number or variable in the denominator, you can split your original fraction into two separate fractions.

$$\frac{25+13}{19} = \frac{25}{19} + \frac{13}{19}$$

Comparing

The Bowtie method is also useful for comparing fractions; this comes in very handy on Quant Comp questions. Just multiply up on the diagonals to compare any two fractions. If you want to compare $\frac{5}{8}$ and $\frac{7}{12}$, for example, multiply 5 by 12 and 8 by 7, then compare. The

larger number, 60, belongs to the larger fraction, $\frac{5}{8}$. Make sure you do this work on your scratch paper and not in your head.

$$\frac{5}{8} \text{ vs } \frac{7}{12} \quad 60 = \frac{5}{8} \times \frac{7}{12} = 56$$

Reducing

In general, get in the habit of reducing all fractions to their simplest forms; it will make your life easier. Before you do, however, have a quick look at the answer choices to make sure your fractions need to be reduced. You don't want to do more work than necessary.

Remember the following rules:

- Do not reduce across a +, -, or = sign. You can reduce individual fractions, but you cannot reduce the numerator of one fraction with the denominator of another, if +, -, or = signs are involved.
- When multiplying fractions, you can reduce anything, including the numerator of one fraction with the denominator of another.
- In $\frac{20}{36}$, you can take fours out of both, not sevens. This is shown with the factoring and cancellation of the twos.

$$\frac{20}{36} = \frac{\cancel{2} \times \cancel{2} \times 5}{\cancel{2} \times \cancel{2} \times 3 \times 3} = \frac{5}{3 \times 3} = \frac{5}{9}$$

Dividing a fraction by a fraction is the same thing as multiplying the first fraction by the reciprocal of the second fraction. You may be able to do this in your head, but don't. Take the extra two seconds to lay it out on your scratch paper. It won't take you much more time, and you're less likely to make a careless error.

$$\frac{\frac{1}{2}}{\frac{3}{4}} = \frac{1}{2} \div \frac{3}{4} = \frac{1}{2} \times \frac{4}{3} = \frac{2}{3}$$

DECIMALS

Occasionally ETS will give you a question in fractions and the answers in decimals, or one side of a Quant Comp in decimals and the other side in fractions. To convert a fraction to a decimal, use long division.

$$\begin{array}{r} 0.428 \\ 7 \overline{)3.000} \\ \underline{28} \\ 20 \\ \underline{14} \\ 60 \\ \underline{56} \\ 4 \end{array}$$

Make sure you check your answer choices and eliminate as you go, so you don't waste time doing extra work. You will rarely have to divide a fraction out to more than two decimal places.

Converting

When converting from a decimal to a fraction, think of the decimal point as a 1 that goes on the bottom of your new fraction; then count up the number of digits that come after the decimal point and add the same number of zeros after the 1.

$$0.42 = \frac{42}{100} \qquad 0.003 = \frac{3}{1000}$$

Multiplying

When you multiply decimals, the answer must have the same number of decimal places as the total decimal places in the numbers you are multiplying. For example, if you multiply .04 by 0.2, the answer must have two places to the right of the decimal, because 0.4 and 0.2 have one decimal place each. The answer is 0.08. Just remember that when you multiply a decimal by a decimal, the answers will get pretty small pretty quickly.

Dividing

When you divide a decimal into a decimal, write it out as long division and convert the divisor into a whole number.

$$\begin{array}{l} \textcircled{1} \\ \underline{.2751} \\ .003 \end{array} \quad \begin{array}{l} \textcircled{2} \\ .003 \overline{) .2751} \end{array} \quad \begin{array}{l} \textcircled{3} \\ \underline{.003} \overline{) .2751} \\ 123 \quad 123 \end{array} \quad \begin{array}{l} 91.7 \\ 3 \overline{) 275.1} \\ \underline{27} \\ 005 \\ \underline{13} \\ 21 \end{array}$$

Since 0.003 is a very small number, it makes sense that it will go into 0.2751 (which is close to 0.3) nearly a hundred times. In fact, if you were Ballparking, you would notice that to get from 0.003 to a number close to 0.3 you would have to move your decimal point to the right two spaces. That is the same as multiplying by 100, so you would be looking for an answer choice that's close to 100. Because 0.2751 is a little bit less than 0.3, you want a number that's a little bit less than 100.

PERCENTAGES

How do you express $\frac{1}{2}$ as a percentage? 50 percent, right? How do you express $\frac{1}{2}$ as a decimal? 0.5, right? You may know that 25 percent, $\frac{1}{4}$ and 0.25 are all the same thing. They are all fractions and they all express a $\frac{\text{part}}{\text{whole}}$ relationship. The first tip for mastering percentages is realizing that they are really just fractions.

These are the most common fraction, decimal, and percentage equivalents; learn them, live them, love them.

Decimal	Fraction	Percentage
0.25	1/4	25%
0.5	1/2	50%
0.75	3/4	75%
1.0	4/4	100%
3.75	15/4	375%
0.33	1/3	33%
0.66	2/3	66%
1.0	3/3	100%
1.66	5/3	166%
0.2	1/5	20%
0.4	2/5	40%
0.6	3/5	60%
0.8	4/5	80%
1.0	5/5	100%
1.2	6/5	120%
2.4	12/5	240%
0.125	1/8	12.5%
0.250	2/8	25%
0.375	3/8	37.5%
0.5	4/8	50%
0.625	5/8	62.5%
0.75	6/8	75%
0.875	7/8	87.5%
1.0	8/8	100%
1.125	9/8	112.5%
2.5	20/8	250%

(Click [here](#) to view a larger image.)

Memorize these fractions and be comfortable switching from one format to another, because when a question asks you for 75 percent, it may be easier to think of the percentage as $\frac{3}{4}$. When a Quant Comp asks you whether $\frac{4}{5}$ or $\frac{6}{8}$ is bigger, it may be easier to think of them as 80 percent and 75 percent.

Translating

Complicated percentages are often expressed as word problems rather than math problems. For example, “42 is what percent of 28”? This problem can be translated, word for word, into a single-variable equation.

Here’s your translation guide.

Word	Symbol
percent	/100
of	* (times)
what	x, y, or z
is, are, was, were	=

Your translation is $42 = \frac{x}{100} \times 28$.

Stress-Free Tip Calculating

How often have you used this one? Your bill is \$28.50. You want to tip 20 percent. You know that 10% = \$2.85. Double it to get \$5.70, and you have 20 percent. You only want to leave 15 percent? Okay, what is half of 10 percent? Let’s call it \$1.43. Add that back to the 10 percent, and you have \$4.28, or 15 percent. You can do this with any number to quickly calculate exact percentages or to quickly ballpark answers.

Number	Percentage
1,246	100%
124.6	10%
12.46	1%

62.3	5%
373.8 (10% × 3)	30%
398.72 (10% × 3 + 1% × 2)	32%

Part to Whole

The last, and perhaps most common, method of quickly calculating percentages is to set up a ratio of part to whole. Remember that the word percent simply means of 100, so 42 percent means 42 parts out of a total of 100.

$$\frac{\text{part}}{\text{whole}} = \frac{x}{100}$$

With this set-up, the variable could go anywhere. ETS might give you the percentage and ask you for the whole. For example, “42 is 60 percent of what”?

$$\frac{42}{x} = \frac{60}{100}$$

To solve, simply cross-multiply: $4,200 = 60x$.

A question might ask you, “42 is what percent of 70”? In this case, the x goes over the 100.

$$\frac{42}{70} = \frac{x}{100}$$

Or a question might ask you, “What is 60 percent of 70”? In this case you know the percentage and the total, but not the part.

$$\frac{x}{70} = \frac{60}{100}$$

Cross-multiply and you can solve. You can always put a percentage into this format.

For more practice and a more in-depth look at The Princeton Review math techniques, check out our student-friendly guidebook, *Cracking the New GRE*.

DRILL 1

Question 1

$$3 \div \frac{6}{7} =$$

$\frac{36}{7}$

$\frac{2}{7}$

$2\frac{4}{7}$

3

$3\frac{1}{2}$

Question 2

$$\frac{\frac{1}{5} - \frac{1}{2}}{\frac{1}{5} + \frac{1}{2}} =$$

$-\frac{1}{2}$

-1

$-\frac{3}{7}$

$\frac{6}{5}$

2

Question 3

Quantity A

$$\frac{15}{16} + \frac{1}{256}$$

Quantity B

$$1 - \frac{1}{64}$$

- Quantity A is greater.
- Quantity B is greater.
- The two quantities are equal.
- The relationship cannot be determined from the information given.

Question 4

A deposit at a local bank earns between 2 percent and 5 percent simple interest in a year. If Shirley makes an initial deposit of \$800 at the bank, which of the following could be the amount of money in her account at the end of one year?

\$814

\$820

- \$842
- \$848
- \$860

Question 5

Quantity A

Quantity B

The change in price of a pair of shoes marked down by 50%

The change in price of a pair of boots marked down by 30%

- Quantity A is greater.
- Quantity B is greater.
- The two quantities are equal.
- The relationship cannot be determined from the information given.

Question 6

Joey works at a clothing store and receives an employee discount of 10 percent off the regular price of any item. What is the regular price of an item that Joey purchases for \$99?

- \$89.10
- \$108.90
- \$109.00
- \$109.90
- \$110.00

Question 7

Rohan began a savings account with a balance of \$200. His current balance is \$150.

Quantity A

Quantity B

The percent decrease from Rohan's original balance to his current balance

The percent increase that would return Rohan's current balance to his original balance

- Quantity A is greater.
- Quantity B is greater.
- The two quantities are equal.
- The relationship cannot be determined from the information given.

Question 8

If 20 percent of x is $5y$, and $y = 7$, what is 60 percent of x ?

- 105
- 115
- 125
- 145

175

Question 9

$$\frac{1}{48} + \frac{1}{48} + \frac{1}{12} + \frac{1}{8} + \frac{1}{4} + \frac{1}{2} =$$

$\frac{49}{48}$

1

$\frac{47}{48}$

$\frac{3}{4}$

$\frac{2}{3}$

Question 10

The Warm Muffin Bakery's cookie sales are always 60 percent of its muffin sales. What would be the increase in The Warm Muffin Bakery's cookie sales if its muffin sales increased from 10,000 to 20,000?

10,000

8,000

6,000

4,000

2,000

Question 11

Quantity A

$$\frac{7}{8} - 0.25$$

Quantity B

$$0.325 + \frac{1}{3}$$

Quantity A is greater.

Quantity B is greater.

The two quantities are equal.

The relationship cannot be determined from the information given.

Question 12

Which of the following inequalities is true?

$\frac{1}{11} < 0.08 < \frac{1}{9}$

$\frac{1}{10} < 0.11 < \frac{1}{8}$

$\frac{1}{7} < 0.17 < \frac{1}{6}$

- $\frac{1}{5} < 0.26 < \frac{1}{4}$
- $\frac{1}{3} < 0.30 < \frac{1}{2}$

Question 13

Company A's output of 245 widgets per week is 35 percent of Company B's weekly widget output.

Quantity A

700

Quantity B

Company B's weekly widget output.

- Quantity A is greater.
- Quantity B is greater.
- The two quantities are equal.
- The relationship cannot be determined from the information given.

Question 14

If $mn \neq 0$, $\frac{2+m}{mn} =$

- $\frac{2}{m} + \frac{2}{mn}$
- $2 + \frac{m}{mn}$
- $\frac{2}{mn} + n$
- $\frac{2}{mn} + \frac{1}{m}$
- $\frac{2}{mn} + \frac{1}{n}$

DRILL 2

Question 1

A car with all available options costs \$18,000, an increase of 20% from the base price of the car.

Quantity A

The base price of the car

Quantity B

\$14,400

- Quantity A is greater.
- Quantity B is greater.
- The two quantities are equal.
- The relationship cannot be determined from the information given.

Question 2

What percent is equivalent to 0.0025?

- $\frac{1}{25}\%$
- $\frac{1}{5}\%$
- $\frac{1}{4}\%$
- 4%
- 5%

Question 3

Which of the following fractions is closest in value to $\frac{5}{8}$?

- $\frac{2}{3}$
- $\frac{3}{4}$
- $\frac{7}{11}$
- $\frac{19}{23}$
- $\frac{23}{30}$

Question 4

A certain brand of imported cigars costs \$30 for a box of 20; when bought individually, the cigars cost \$2 each.

Quantity A

The percent saved when a box of cigars is purchased, rather than 20 individual cigars

Quantity B

$33\frac{1}{3}$

- Quantity B is greater.
- The two quantities are equal.
- The relationship cannot be determined from the information given.

Question 5

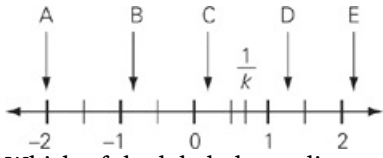

Which of the labeled coordinates on the number line above could represent the value of k ?

- A
- B
- C
- D
- E

Question 6

$$(4 \times 100) + (6 \times 1,000) + (2 \times 1) + (3 \times 10) =$$

- 2,346
- 4,632
- 4,623
- 6,324
- 6,432

Question 7

What is the value of $\frac{3}{\left(\frac{3}{4}\right)} - \frac{\left(\frac{3}{2}\right)}{3}$?

- $-\frac{7}{4}$
- $-\frac{3}{4}$
- 1
- 2
- $\frac{7}{2}$

Question 8

Quantity A

a

Quantity B

b

- Quantity A is greater.
- Quantity B is greater.
- The two quantities are equal.
- The relationship cannot be determined from the information given.

Question 9

$$\frac{\frac{x}{5} + \frac{x}{5} + \frac{x}{5} + \frac{x}{5}}{4} =$$

- 16x
- $\frac{24x}{5}$
- 4x
- $\frac{4x}{5}$
- $\frac{x}{5}$

Question 10

$$n > 0$$

$$\frac{6n}{15}, 0.3n, \frac{19n}{50}, \frac{n}{4}$$

Quantity A

The positive difference between the greatest and least values above

Quantity B

Three times the positive difference between the two least values above

- Quantity A is greater.
- Quantity B is greater.
- The two quantities are equal.
- The relationship cannot be determined from the information given.

Question 11

Halfway through the season, Antonio's scoring average per game was 20% higher than David's. The two scored the same number of points in the second half of the season.

Quantity AQuantity B

90% of Antonio's scoring average for the whole season

David's scoring average for the whole season

- Quantity A is greater.

- Quantity B is greater.
- The two quantities are equal.
- The relationship cannot be determined from the information given.

Question 12

The annual interest rate on a certain savings account increases from 1.25% to 1.5%. What percent increase in the annual interest rate does this change represent?

- 0.2%
- 0.25%
- 0.167%
- 20%
- 25%

Question 13

Which of the following is equal to $\frac{1}{5}$ of the reciprocal of 0.004 percent?

- 0.5
- 50
- 500
- 5,000
- 50,000

Question 14

Quantity A

The total value of 100 dollars after it is invested for m months at 8 percent simple annual interest

Quantity B

$$100 \left(1 + \frac{0.08}{m} \right) \text{ dollars}$$

- Quantity A is greater.
- Quantity B is greater.
- The two quantities are equal.
- The relationship cannot be determined from the information given.

DRILL 3

Question 1

27 percent of p is 100.

p is q percent of 100.

Quantity A

q

Quantity B

400

- Quantity A is greater.
- Quantity B is greater.
- The two quantities are equal.
- The relationship cannot be determined from the information given.

Question 2

Which expression is equivalent to $\frac{1}{y - \frac{1}{y}} - y$?

- $\frac{y^3 + y - 1}{y^2 - 1}$
- $\frac{2y - y^3}{y^2 - 1}$
- $\frac{-y^3}{y^2 - 1}$
- $y^3 + y - 1$
- $-y - 1$

Question 3

One cup of nuts that contains exactly half peanuts and half cashews is added to a bowl of nuts that is exactly one third peanuts, one third cashews, and one third almonds. This results in a three-cup mixture of nuts. What fraction of the new nut mixture is peanuts?

$$\frac{\boxed{}}{\boxed{}}$$

Question 4

Quantity A

16 percent of 83

Quantity B

83 percent of 16

- Quantity A is greater.
- Quantity B is greater.
- The two quantities are equal.

Question 5

Leah wants to shrink her photos to fit a computer screen. Her photos currently have a width of 1,024 pixels and a height of 768 pixels. If she reduces the width to 800 pixels, then to what height, in pixels, must she reduce the photos to preserve the same ratio of width to height?

- 1,066.7
- 600
- 576
- 544
- 500

Question 6

What is w if $\frac{1}{9}(w + 1) = \frac{1}{729}$?

Question 7

Maria removed $\frac{5}{6}$ of the cookies from a jar, and then Andrea removed $\frac{3}{8}$ of the remaining cookies from the same jar. Which of the following could NOT be the number of cookies originally in the jar?

Indicate all possible values.

- 6
- 15
- 30
- 60
- 200
- 210
- 340

Question 8

If $.002x + .004y = 4$, what is the value of y in terms of x ?

- $\frac{4 - 2x}{.04}$
- $\frac{4000 - .002x}{.04}$
- $4 - .5x$
- $1000 - .5x$
- $2(1000 - x)$

Question 9

What is the tenths digit of the quotient when thirty-five hundredths is divided by four thousandths?



Question 10

A group of freshmen, juniors, and seniors are going on a school trip. The number of seniors is 60% of the number of juniors, which is 50% of the number of freshmen. If there are at least 150 students on the trip, then which of the following could be the number of seniors?

Indicate all possible values.

- 21
- 22
- 24
- 25
- 27

Question 11

Between the first day of May and last day in June, the price per kilogram of Melange, a seasoning mix, first declined by 20 percent and then increased by 50 percent. During this same period, the price per liter of Blue, a spring water, first increased by 20 percent and then declined by 50 percent. If at the end of June, the prices were the same, then, at the beginning of May, the price per kilogram for Blue was what percent of the price per liter of Melange?

- 2
- 30
- 50
- 100
- 200

Question 12

A container is $\frac{4}{5}$ full. After 3 liters of its contents are poured out, the container is $\frac{3}{4}$ full. How many liters would need to be poured back in to refill the container?



Question 13

The selling price of a house was decreased by 12 percent to \$220,000. What was the original selling price of the house?

- \$193,600
- \$196,429
- \$221,200
- \$246,400
- \$250,000

DRILL 4

Question 1

In 2009, the price of each Econolux car increased by 10 percent from the 2008 price. In 2010, they decreased by 5 percent and now cost between \$18,000 and \$19,800. Which of the following could be the price of a 2008 Econolux car?

Indicate all possible values.

- \$17,030
- \$17,230
- \$18,180
- \$18,935
- \$18,955
- \$20,790

Question 2

$$\frac{(0.05)(0.5)}{(5)(0.005)} =$$

Question 3

Which of the following are greater than 1?

Indicate all possible values.

- $\frac{4(3 + 0.07)}{11.092}$
- $\frac{\sqrt{82} - 1.7^2}{\sqrt{34}}$
- $\frac{9978.4 - 0.0083}{101^2}$
- $\frac{\sqrt{143} \times \sqrt[3]{7}}{24.034}$

Question 4

If during a one-day period the Q train arrives at the station 30% less frequently than the B train, and the B train arrives 10% less frequently than the F train, then the Q train's frequency is what percent of the F train's frequency?

- 27
- 40
- 60
- 63
- 90

Question 5

$67,345 \times 10^{15}$ is equivalent to which of the following?

Indicate all possible values.

- 6.7345×1000^{13}
- 673.45×10^{16}
- 6.7345×10^{16}
- 67.345×100^{14}
- 0.0067345×10^{18}

Question 6

The sum $\frac{3}{10} + \frac{43}{100} + \frac{17}{1000}$ is equivalent to which of the following sums?

- $\frac{700}{1000} + \frac{4}{10} + \frac{7}{100}$
- $\frac{6}{10} + \frac{12}{100} + \frac{37}{1000}$
- $\frac{7}{100} + \frac{4}{10} + \frac{7}{1000}$
- $\frac{7}{100} + \frac{4}{1000} + \frac{7}{10}$
- $\frac{32}{100} + \frac{4}{10} + \frac{27}{1000}$

Question 7

An investment club has had an average rate of return of 15% per year for the past 6 years. If Teresa invests \$1000 today and neither adds nor subtracts money from the club, how much will Teresa have invested after 5 years assuming that the rate of return does not change?

- $1000 + 1.15^5$
- $1000(1.15)^5$
- $1000 + 0.15$
- $1000(0.15)^5$
- $1000(5)^{0.15}$

Question 8

If $\frac{\left(\frac{3}{x^2}\right)^2}{x^6} = 8^{-1}$, then what is the value of x?

Question 9

Ben's music album sold $\frac{5}{6}$ the number of copies as Regina's album. If Regina's album sold at least 1,500 copies more than Ben's album, how many copies of Ben's album were sold?

Indicate all possible values.

- 12,000

- 11,244
- 9,000
- 6,500
- 6,436
- 4,225

Question 10

Carmen wants to open a special savings account through her work. If Carmen invests \$7,000 at 6 percent simple annual interest in January, and no other money is added to or removed from the account, which of the following is true?

Indicate all possible values.

- At the end of April, Carmen will have earned \$105 in interest.
- At the end of the year, Carmen will have earned \$420 in interest.
- At the end of six months, Carmen will have earned \$35 in interest.
- At the end of three months, Carmen will have \$7,105 in the account.

Question 11

If each of three grocery stores receives $\frac{1}{4}$ of a farmer's potato crop, a farmer's market receives $\frac{1}{3}$ of the remaining, and a local fast food restaurant receives the remaining 200 pounds, how many pounds of potatoes were in the farmer's crop?

- 300
- 400
- 900
- 1,200
- 1,400

Question 12

The price of Mabel's car, not including interest, is 12 percent more than the price of Rose's car. Combined, Mabel and Rose's cars cost \$53,000. If Mabel's car loan interest rate was 5.20 percent, what was the total cost of Mabel's car, including interest?

Question 13

Evangeline must spend $\frac{3}{8}$ of her weekly salary on rent and $\frac{1}{6}$ of her remaining salary on food. Which of the following could be percentages of her weekly salary that Evangeline devotes to entertainment, while still enabling her to place $\frac{4}{9}$ of her salary into a savings account?

Indicate all such percentages.

- 0.5%
- 5.0%
- 7.5%

- 10.0%
- 15.0%
- 25.0%
- 50.0%

ANSWERS

Drill 1

1. E
2. C
3. B
4. B
5. D
6. E
7. B
8. A
9. B
10. C
11. B
12. B
13. C
14. E

- Drill 2
1. A
 2. C
 3. C
 4. B
 5. D
 6. E
 7. E
 8. B
 9. E
 10. C
 11. D
 12. D
 13. D
 14. D

Drill 3

1. B
2. B
3. $7/18$
4. C
5. B
6. $-80/81$
7. A, B, E
8. D
9. 5
10. C, E
11. E
12. 15
13. E

Drill 4

1. B, C, D
2. 1
3. A, B
4. D
5. C, D, E
6. E
7. B
8. 2
9. A, C
10. B, D
11. D
12. 29,456
13. A, B, C

Drill 1

1. E When dividing by a fraction, flip the fraction and multiply: $3 + \frac{6}{7} = 3 \times \frac{7}{6} = \frac{21}{6} = 3\frac{1}{2}$. Alternatively, you may estimate and realize that 3 divided by something slightly smaller than 1 must be slightly larger than 3.
2. C Use the Bowtie when adding or subtracting fractions: $\frac{1}{5} - \frac{1}{2} = \frac{2-5}{10} = -\frac{3}{10}$. Next, divide the fractions by flipping the numerator and denominator and multiplying: $-\frac{3}{10} = (-\frac{3}{10}) \times (\frac{10}{7}) = -\frac{3}{7}$.
3. B In Quantity A, $\frac{15}{16} + \frac{1}{256} = \frac{241}{256}$, and in Quantity B, $1 - \frac{1}{64} = \frac{63}{64}$. If you multiply the numerator and denominator of $\frac{63}{64}$ by 4, you obtain a common denominator: $\frac{63}{64} = \frac{252}{256}$. Clearly $\frac{252}{256} > \frac{241}{256}$, so Quantity B is greater.
4. B 5% of \$800 is \$40, thus, the maximum amount of money that could be in the account at the end of one year is \$840; eliminate choices (C), (D), and (E). Similarly, the minimum amount that could be in the account at the end of one year is \$800 plus 2% of \$800, or \$816; eliminate choice (A).
5. D Be careful: You're not given the original price of either pair of shoes, and because you can't assume they're the same price, try Plugging In a variety of values. If the shoes in both quantities originally cost 10 dollars, then the change in price of the shoes in Quantity A is 5 dollars, and the change in price of the shoes in Quantity B is 3 dollars; Quantity A is greater, so eliminate choices (B) and (C). If the shoes in Quantity B originally cost 20 dollars, though, then the change in price is 6 dollars. Quantity B is now greater, so eliminate choice (A), and you're left with choice (D), the correct answer.
6. E With his employee discount, Joey purchases an item for 90% of its regular price, so 90% of the regular price of this item is equivalent to \$99 or $\frac{90}{100}x = 99$. Solve for x to find that the regular price is \$110.
7. B The percent change formula is $\frac{\text{difference}}{\text{original}} \times 100$. Remember that the "original" is the amount before the change. So, in Quantity A, the difference is $200 - 150 = 50$, and the original is 200, which yields a 25% change. In Quantity B, the difference is also 50, but the number changes from 150 to 200, so the "original" is 150, which yields roughly a 33.3% change. Thus, Quantity B is greater.
8. A Begin by Plugging In 7 for y, so 20 percent of x is 35. You could go on to solve for x, but a shortcut would be to say that 60 percent of x is three times 20 percent of x, so multiply 35 by 3 to get 105.
9. B You have far too many fractions to add quickly with the Bowtie. Instead, convert all of the fractions to the common denominator of 48: $\frac{1}{48} + \frac{1}{48} + \frac{1}{12} + \frac{1}{8} + \frac{1}{4} + \frac{1}{2} = \frac{1+1+4+6+12+24}{48} = \frac{48}{48} = 1$.
10. C If The Warm Muffin Bakery sells 10,000 muffins, it sells 6,000 cookies. If the Warm Muffin Bakery then sold 20,000 muffins, it would sell 12,000 cookies. The cookie sales would thus increase by 6,000.
11. B Convert the fractions to decimals. So $\frac{7}{8} = 0.875$, making Quantity A 0.625. In Quantity B, $\frac{1}{3}$ is about 0.333, making Quantity B about 0.658. Quantity B is greater.
12. B Convert the fractions to decimals to see which inequality is correct. You can divide them out (remember, numerator divided by denominator), but it might help to have some common fraction/decimal equivalents memorized. Starting with choice (A), $\frac{1}{11} \approx 0.09$,

13. C Translate the question into a percent formula. So, "245 widgets per week is 35 percent of Company B's weekly widget output" means

$$245 = \frac{35}{100} \times B. \text{ Try Plugging In Quantity A into this formula. Does } \frac{35}{100} \times 700 = 245? \text{ Yes, so the quantities must be equal.}$$

14. E Plug In for the variables. Let $m = 3$ and $n = 5$, and $\frac{2+3}{3 \times 5} = \frac{5}{15} = \frac{1}{3}$. Only choice (E) works. Alternatively, you could manipulate the

fractions: $\frac{2+m}{mn} = \frac{2}{mn} + \frac{m}{mn} = \frac{2}{mn} + \frac{1}{n}$.

1. A The question asks for a percent increase from the original price; be careful not to find 20% of \$18,000, and reduce the higher total (\$18,000) by that amount. Instead, you'll need to find the amount that yields the higher total, when increased by 20%, though, it's much easier to just increase the price in Quantity B and compare it to the total in the problem: 10% of \$14,400 is \$1,440, so 20% must be \$2,880; adding this to the base price of \$14,400 yields a total of \$17,280. That's smaller than what you were looking for, so Quantity A is greater.
2. C Convert 0.0025 to a percent by sliding the decimal point two places to the right: 0.25%. Then convert 0.25 to a fraction to get $\frac{1}{4}$.
3. C There are two ways to go about this problem. One is to use the Bowtie method to compare fractions. $\frac{2}{3}$ versus $\frac{5}{8}$ yields a 16 versus 15. Pretty close. $\frac{3}{4}$ versus $\frac{5}{8}$ yields 24 versus 20. Not as close, so eliminate it. $\frac{7}{11}$ versus $\frac{5}{8}$ yields 56 versus 55, that's really close on a percentage basis because the numbers are bigger. Eliminate choice (A). $\frac{19}{25}$ versus $\frac{5}{8}$ yields 152 versus 115. Get rid of it. Choice (E) yields 18 versus 50. Get rid of it. Alternatively, you could also use long division, but if you do, there is no need to finish out the math for each answer. 5 divided by 8 = 0.625. $\frac{2}{3} = 0.66$. Keep it. When you start to divide 3 by 4, the first number you see is a 7. Don't continue to divide, just eliminate it because 0.7 is farther from 0.625 than 0.66. Choice (C) yields 0.63, so keep it and eliminate choice (A). The answer is 19 divided by 23 begins with 0.8, so get rid of it. The answer to 23 divided by 30 begins with 0.7 so get rid of that too.
4. B Twenty cigars bought individually would cost \$40, so apply the percent change formula— $\frac{\text{difference}}{\text{original}} \times 100$ —to determine Quantity A. In this case, the difference is \$10, and the original, because it's a percent decrease, is \$40: $\frac{10}{40} \times 100 = 25$, so Quantity A is 25%. Quantity B is greater.
5. D Try Plugging In a possible value for $\frac{1}{k}$. If $\frac{1}{k} = \frac{3}{4}$, then $\frac{4}{3}$, which is closest to coordinate D.
6. E This question is really asking about place value. Start with the greatest place: the thousands. So, $6 \times 1,000$ means a 6 in the thousands place. Eliminate choices (A), (B), and (C). Next, 4×100 means the next digit should be 4. Eliminate choice (D), and select choice (E).
7. E To calculate this expression, break it into pieces: $\frac{3}{\left(\frac{3}{4}\right)} - \frac{\left(\frac{3}{2}\right)}{3} = 3 \div \frac{3}{4} - \frac{3}{2} \div 3 = 3 \times \frac{4}{3} - \frac{3}{2} \times \frac{1}{3} = 4 - \frac{1}{2} = \frac{7}{2}$.
8. B Solve each equation by translating into algebra. The first is $a = \frac{40}{100} \times 45$. Reduce and multiply to find $a = 18$. The second is $18 = \frac{b}{100} \times 90$. Multiply both sides by 100 then divide by 90 to find $b = 20$. Quantity B is greater.
9. E Plug in a value for x: If $x = 20$, then the expression $\frac{\frac{20}{5} + \frac{20}{5} + \frac{20}{5} + \frac{20}{5}}{4}$ becomes $\frac{4+4+4+4}{4} = \frac{16}{4} = 4$. Now Plug in 20 for x in the answer choices; only choice (E) hits your target answer of 4. Alternatively, you could factor the expression: $\frac{\frac{x}{5} + \frac{x}{5} + \frac{x}{5} + \frac{x}{5}}{4} = \frac{4 \times \left(\frac{x}{5}\right)}{4} = \frac{x}{5}$.
10. C The first thing you need to do is to clean up these expressions. You have 15th, 50th, and decimals, so it is very difficult to compare

values. $\frac{6n}{15}$ can be reduced to $\frac{2n}{5}$. $0.3n$ is the same as $\frac{3n}{10}$. Change your first expression from $\frac{2n}{5}$ to $\frac{4n}{10}$. $\frac{19n}{50}$ is pretty close to $\frac{20n}{50}$, the first expression, but a bit smaller. Because $\frac{n}{4}$ is clearly the smallest expression and you need only concern yourself with the smallest, the second smallest, and the biggest, you can ignore $\frac{19n}{50}$. Convert $\frac{n}{4}$ to $\frac{5n}{20}$, and convert your other expressions to 20ths as well. You now have $\frac{8n}{20}$, $\frac{6n}{20}$, and $\frac{5n}{20}$. The difference between the smallest and largest is $\frac{3n}{20}$. Three times the difference between the two smallest is also 3. The answer is choice (C).

11. D Plug in some real numbers to compare quantities. For example, plug in 10 for the number of games in the season. For the first 5 games of the season, try an average of 10 points for David (for a total of 50 points), which makes an average of 12 points for Antonio (for a total of 60 points). Next, try a total of 0 points for each player for the second half of the season; now Antonio's average for the season is 6 points, and David's is 5. Because 90% of 6 is 5.4, Quantity A is greater, so eliminate choices (B) and (C). Finally, try a total of 100 points for each player for the second half of the season; now Antonio has scored a total of 160 points in 10 games, for an average of 16 points, and David has scored a total of 150 points in 10 games, for an average of 15 points. Because 90% of 16 is 14.4, Quantity B is now greater, so eliminate choice (A), and you're left with choice (D).

12. D The percent change formula is $\frac{\text{difference}}{\text{original}} \times 100$, so plugging the numbers from the problem into the formula yields $\frac{0.25}{1.25} \times 100 = \frac{25}{125} \times 100 = \frac{1}{5} \times 100 = 20$. If you selected choice (E), you may have used the wrong value as the original: Remember, in a percent increase, the original number is the smaller value.

13. D Solve this problem in chunks. To find the numerical value for 0.004 percent, divide by 100: $0.004 \div 100 = 0.00004$. The reciprocal of that is $\frac{1}{0.00004} = 25,000$. So $\frac{1}{5}$ of the result is $\frac{1}{5} \times 25,000 = 5,000$.

14. D Plug in values for m. When m = 1, Quantity B is larger. When m = 12, Quantity A is larger.

1. B To find exact values for p and q , apply percent translation: $\frac{27}{100} \times p = 100$, so $\frac{27p}{100} = 100$, $27p = 10,000$, and $p = 370.37$; p is q percent of 100, so $q = 370.37$ as well. Quantity B is greater. Alternatively, you could avoid the calculation altogether and Ballpark this one all the way through: 100 is more than 25% (or $\frac{1}{4}$) of p , so p must be less than 400—and so must q .
2. B This is a good problem for Plugging In. If $y = 2$, then the expression becomes equal to $-\frac{4}{3}$. Choice (B) is the only choice that gives you $-\frac{4}{3}$ when you replace y with 2.
3. **18** $\frac{7}{18}$ The total mixture contains three cups, so the second bowl must contain two cups. This 2-cup bowl of nuts divided into even thirds consists of $\frac{2}{3}$ cups peanuts, $\frac{2}{3}$ cups cashews, and $\frac{2}{3}$ cups almonds. Combining this with the 1-cup mixture of $\frac{1}{2}$ cup peanuts and $\frac{1}{2}$ cup cashews results in $\frac{7}{6}$ cups peanuts in a 3-cup mixture. So, $\frac{7}{6} = \frac{7}{18}$ of the new nut mixture is peanuts.
4. C To find 16 percent of 83, multiply 83 by 0.16. To find 83 percent of 16, multiply 16 by 0.83. Both expressions yield 13.28, so choice (C) is correct.
5. B Set up a proportion so that the original ratio equals the final ratio: $\frac{1024}{800} = \frac{768}{x}$. Cross-multiply and then divide both sides by 1024 to find $x = 600$.
6. **81** $-\frac{80}{81}$ One easy way to solve this problem is to multiply both sides of the equation by 9, which gives you $(w + 1) = \frac{9}{729}$, or $(w + 1) = \frac{1}{81}$. Now subtract 1 from both sides to get $-\frac{80}{81}$.
7. A, B, and E
 Anything that's a multiple of 30 will work here because of the two denominators of the two fractions in the question. Choices (C), (D), and (E) are all multiples of 30, but the remaining answers are not. You can also treat this as a PITA problem and try each answer. Take $\frac{5}{6}$ of each of the answer choices, then take $\frac{3}{5}$ of what's left. Do you wind up with an integer? If so, eliminate it and keep working until you've tried every answer.
8. D Sure, you could use algebra here, but most likely you won't wind up with an answer that looks anything like choice (D). Instead, try plugging in a value for x . Make x something easy such as 1000, which makes $y = 500$. Plug $x = 1000$ into each answer choice, and it turns out that only choice (D) gives you the correct value of 500.
9. 5 First, translate the English into math. Thirty-five hundredths is 0.35 and four thousandths is 0.004. Now, do the division on your on-screen calculator; the first place after the decimal point is the tenths digit, so the answer is 5.
10. C and E
 To solve this question, plug in the answers as the number of seniors to see if the rest of the class adds up to 150. Start with choice (C). If $S = 24$, then $\frac{60}{100}$ and $J = 40$; since $40 = 50\%$ of F , then $F = 80$; since the sum of the students is $24 + 40 + 80 = 144$, which is less than 150, try larger numbers and eliminate choices (A), (B), and (C). For choice (D), if $S = 25$, then $25 = \frac{60}{100} J$, thus there are 41.67 juniors, which is incorrect since it is impossible to have a fraction of a student. For choice (E), if $S = 27$, then $\frac{60}{100} J$, thus $J = 45$; since $45 = 50\%$ of F , then $F = 90$; since $27 + 45 + 90 = 162$, which is at least 160, choice (E) is the only correct answer.

11. E Since the problem doesn't give you prices, Plug In; since the question involves percents, use 100. If the starting price for Melange was \$100, then, after the 20% decrease, the price was \$80; increase that by 50%, or $\frac{1}{2}$, and the ending price was \$120. Since the ending prices for Melange and Blue were the same, the ending price for Blue was also \$120. Now, work backwards. Declining by 50% is the same as being cut in half; if Blue was \$120 after being cut in half, it must have been \$240 before the decrease. Since that \$240 was the result of a 20% increase, translate the question "240 is 120% of what" to get the equation $240 = \frac{120}{100} \times x$; solve for x to get the starting price for Blue, \$200. Finally, now that you have both starting prices, translate the question into $20 = \frac{x}{100} \times 100$, and solve for x to get your answer, 200.

12. 15 We know that the difference between $\frac{4}{5}$ and $\frac{3}{4}$ of the container is 3 liters, so set up the following equation to solve for the volume of the container:

$$\left(\frac{4}{5} - \frac{3}{4}\right)x = 3$$

$$\left(\frac{16}{20} - \frac{15}{20}\right)x = 3$$

$$\left(\frac{1}{20}\right)x = 3$$

$$x = 60$$

Since the container is still $\frac{3}{4}$ full, it has 45 liters in it. Therefore, you'll need to pour 15 liters back in.

13. E Plug in the answers. Subtract 12 percent from each answer choice to find the one that gives you 220,000. Start with choice (C):

\$193,600
 \$196,429
 $\$221,200 - .12(\$221,200) = 194,656$
 $\$246,400 - .12(\$246,400) = 216,832$
 $\$250,000 - .12(\$250,000) = 220,000$

1. B, C, and D

It's useful to use PITA in this problem. Note that increasing something by 10 percent is the same as multiplying by 1.10, and decreasing something by 5 percent is the same as multiplying by 0.95. Definitely use your on-screen calculator on a problem such as this. Because you are dealing with a range, it will save you time to work from the top down until you reach a correct answer, then work your way from the bottom up until you reach a correct answer. Each answer in between the smallest correct answer and the largest correct answer must also be correct.

2008	2009	2010	Between 18,000 and 19,800?
	$\times 1.1$	$\times .95$	
\$17,030	18,733	17,796	too small
\$17,230	18,953	18,005	yes
\$18,180			must also be correct
\$18,935	20,828	19,787	yes
\$18,955	20,851	19,808	too big
\$20,790	22,869	21,726	too big

2. 1 Sometimes dealing with fractions is easier than dealing with decimals, and sometimes vice versa. Here are both methods. When multiplying decimals, count how many total digits or decimal places there are to the right of the decimal point, then put the decimal point that many places to the left once you've done the multiplication. So $(0.05)(0.5) = 0.025$ (2 digits for 0.05 and 1 digit for 0.5, so 3 total digits and therefore 3 places to the left).

$$(5)(0.005) = 0.025$$

They equal the same thing, so the answer is 1. When dealing with fractions, just remember that for each decimal place, you add another zero on the bottom. So $0.05 = \frac{5}{100}$, because you put two zeroes on the bottom, one for each of the two digits to the right of the decimal point. Or, you could convert the decimals to fractions and then multiply:

$$\left(\frac{5}{100}\right)\left(\frac{5}{10}\right) = \frac{25}{1000}$$

$$(5)\left(\frac{5}{1000}\right) = \frac{25}{1000}$$

Again, you get the same fractions on the top and bottom.

3. A and B You can use your on-screen calculator, but it will probably be faster to ballpark on at least some of these—for example, think of $\sqrt{82}$ as slightly more than 9, or $\sqrt{34}$ as slightly less than 6. In order to figure out which fractions are greater than one, just figure out if the top part of the fraction is bigger than the bottom part:

$\frac{4(3+.07)}{11.092}$: top bigger than 12, bottom smaller, so choice (A) works;

$\frac{\sqrt{82}-1.7^2}{\sqrt{34}}$: top bigger than 6, bottom smaller, so choice (B) works;

$\frac{9978.4-.0083}{101^2}$: top smaller than 10,000, bottom bigger, so eliminate choice (C);

$\frac{\sqrt{143} \times \sqrt[3]{7}}{24.034}$: top smaller than 24—you might think of it as less than 12 times less than 2—bottom bigger, so eliminate choice (D).

4. D To solve this question Plug In. Since the question deals with percents, try 100. If the F train arrives 100 times per day, then the B will arrive 10% fewer times than 100: $B = (1 - \frac{10}{100})F = (\frac{90}{100})100 = 90$ times, and the Q will arrive 30% fewer times than 90: $Q = (1 - \frac{30}{100})B = (\frac{70}{100})90 = 63$ times. Translating the question “the Q train’s frequency is what percentage of the F train’s” gives $Q = (\frac{x}{100})F$ and thus $63 = (\frac{x}{100})100$, which means that the Q’s frequency is 63% of the F’s. The correct answer is choice (D).

5. C, D, and E

To solve this question, remember that for every space the decimal in the base number moves to right, the power of ten should decrease by 1, and vice versa. For choice (A), $1000^{13} = 10^{15}$, so the decimal should not have moved. In choice (B), moving the decimal 1 space to the right means that 10^{15} should decrease by 1 to become 10^{14} . Eliminate choices (A) and (B). For choice (C), moving the decimal 1 space to the left means that the power should increase by 1; this is correct. For choice (D), 100^{14} is equivalent to 10^{15} , so this is correct. For choice (E), moving the decimal 3 spaces to the left means that the power should increase by 3; this is

correct. The correct answers are (C), (D), and (E).

6. E To solve this question, convert the fractions into decimals and carefully add them. $\frac{3}{10} + \frac{43}{100} + \frac{17}{1000} = 0.3 + 0.43 + 0.017 = 0.747$; this is your target answer. Choice (A) equals $0.7 + 0.4 + 0.07 = 1.17$. Choice (B) equals $0.6 + 0.12 + 0.037 = 0.757$. Choice (C) equals $0.07 + 0.4 + 0.007 = 0.477$. Choice (D) equals $0.07 + 0.004 + 0.7 = 0.774$. Choice (E) equals $0.32 + 0.4 + 0.027 = 0.747$. The correct answer is choice (E).

7. B To solve this question, remember that the formula for finding the result of periodic increases at a certain rate is (Original Amount)(1 + rate)^{number of periods}. In this case, the final amount would be $1000(1.15)^5$. The correct answer is choice (B). If you forgot the formula, you could calculate the final amount after 5 years, and then calculate all the answers for a match.

8. 2 To solve this question, remember the rules of exponents. When an exponent is outside a parentheses, it gets multiplied to any exponents inside the parentheses; thus $(x^{\frac{3}{2}})^2 = x^3$. Next, since when two numbers of the same base are divided, the exponents are subtracted, x^3 divided by $x^5 = x^{3-5} = x^{-2}$. Since a negative exponent is equal to its reciprocal, then $x^{-2} = \frac{1}{x^2} = 8^{-1} = \frac{1}{8}$ and thus $x^3 = 8$. Thus, $x = 2$, the correct answer.

9. A and C To solve this question, plug in the answers. In choice (D), if Ben, B, sold 6500 copies and $B = \frac{5}{6}R$, then $6500 = \frac{5}{6}R$, so Regina, R, sold 7800 copies, thus giving a difference of $7800 - 6500 = 1300$. Since this is too small, eliminate choices (D), (E), and (F) and try larger numbers. In choice (C), if $B = 9000$, then $9000 = \frac{5}{6}R$, so $R = 10,800$, thus giving $10,800 - 9000 = 1800$; since this is bigger than 1500, keep choice (C). In choice (B), if $B = 11,244$, then $11,244 = \frac{5}{6}R$, so $R = 13,492.8$ copies; eliminate choice (B), as it is impossible to sell a fraction of an album. In choice (A), if $B = 12,000$, then $12,000 = \frac{5}{6}R$, so $R = 14,400$ and $14,400 - 12,000 = 2400$. Since this is bigger than 1500, keep choice (A). The correct answers are choices (A) and (C).

10. B and D

To calculate the interest earned, multiply the principal by the annual interest rate: in one year, Carmen will earn $\$7000 \times 0.06 = \420 in interest, so choice (B) works. To calculate her interest for any part of the year, divide $\$420$ by the appropriate fraction of a year. At the end of April, $\frac{1}{3}$ of the year has passed, so Carmen will have earned $\frac{1}{3} \times \$420 = \140 ; eliminate choice A. At the end of six months, Carmen will have earned $\frac{1}{2} \times \$420 = \210 ; eliminate choice (C). At the end of three months, $\frac{1}{4}$ of the year has passed, so Carmen has earned $\frac{1}{4} \times \$420 = \105 ; there will be a total of $\$7000 + \$105 = \$7105$ in the account, so choice (D) works.

11. D Since you know there are 200 lbs remaining after the grocery stores and farmer's market get their shares, you cannot plug in your own number. So plug in the answers, and start with middle choice (C):

Total	$-\frac{3}{4}$ to grocery stores	$\frac{1}{3}$ of remaining	remaining = 200?
300			
400			
900	225	75	150 – too small
1200	300	100	200
1400			

12. 29,456

First set up the first part of the question to calculate Mabel's car cost without interest. Let Mabel = m and Rose = r. So, $1.12r = m$ and $r = 53,000$. Substitute: Since $r + 1.12r = 53,000$, then $2.12r = 53,000$. Solve: $r = 25,000$ and $m = 28,000$. Now, you can

multiply m by the interest rate. $(28,000)(.052) = 1,456$ of interest. Add it to the price of the car to get $28,000 + 1,456 = 29,456$.

13. A, B, and C

The problem has percents in the answers and no real values in the question, so it's a Hidden Plug In; the hidden variable in this case is Evangeline's weekly salary. To find an easy number, try multiplying the denominators in the problem: $8 \times 6 \times 9 = 432$, so Evangeline makes \$432 per week. Now work the problems in bite-sized pieces. She spends $\frac{3}{8}$ of \$432, or \$162, on rent, leaving her with $432 - 162 = 270$. Of that, she spends $\frac{1}{6}$, or \$45, on food, leaving her with $270 - 45 = 225$. If she wants to put $\frac{4}{9}$ of her weekly salary, or \$192, into a savings account, then she can only spend $225 - 192 = 33$ on entertainment. Finally, use your on-screen calculator to determine that 33 is just over 7.6% of 432, so choices (A), (B), and (C) will all work.

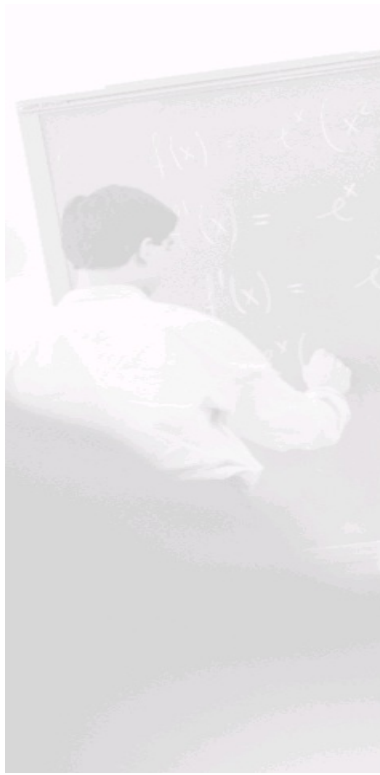

Ratios and Proportions

RATIOS AND PROPORTIONS

Much like averages, rates, and Quant Comp Plug Ins, ratios are all about organizing your information. That means recognizing when and how to effectively use your scratch paper.

USE A RATIO BOX

A ratio is simply a fraction. Rather than expressing a part-to-whole relationship, it expresses the relationship between two parts. The two parts combined make up the whole. If you have a bag with 5 red marbles and 4 blue marbles, your ratio of red to blue is 5 : 4. Ratios can be expressed as fractions, so you can also express the relationship as $\frac{5}{4}$. Either way your total number of marbles is 9, because 5 plus 4 is 9.

You can keep the same ratio of red to blue marbles as long as you increase your total to a multiple of 9. If you had 27 marbles total, you would have 15 red and 12 blue, but your ratio would still be 5 : 4. To keep it straight, use a ratio box.

The minute you see the word RATIO, draw a ratio box on your scratch paper.

Here's what the ratio box looks like.

Red Marbles	Blue Marbles	Total	
5	4	9	← Ratio Total
×3	×3	×3	← Multiplier
15	12	27	← Actual Total

In this case you know that the ratio of red to blue marbles is 5 : 4, but the actual numbers of red and blue marbles are 15 and 12. $\frac{4}{9}$ of the marbles are blue, and approximately 55 percent ($\frac{5}{9}$) of the marbles are red. Unless a question asks for fractions of marbles, the actual total of marbles must be a multiple of nine.

As usual, ETS will give you just enough information to fill out the chart. The question may give you the actual number of marbles, the ratio of red to blue, and then ask you for the actual number of blue marbles. Alternatively, the question may ask you what the new ratio will be if the number of blue or red marbles is increased. A really tricky question may state that some blue ones have been added, give you the new ratio, and then ask you for the actual total of red ones. No matter what is asked, a ratio is still a ratio; the ratio box will organize the information you're given and help you get the information you need.

RATIO AND RATES

Sometimes you will be given a simple ratio in the form of a rate. The question may tell you the number of widgets a factory can produce in an hour, the price of one gallon of gasoline, and the speed with which a silo fills with grain. You will then have to scale this rate up or down, depending on what is asked. Alternatively, you may have to find the number of widgets the factory will produce in ten hours, the price of a 30 gallon tank of gasoline, or the percentage of the silo that will be filled in two hours. To solve these rate problems, set them up as proportions on your scratch paper, check your units, and label everything.

Example:

A digital scanner can scan five lines every second. If each line is one eightieth of an inch, how many minutes will it take to scan a 4½ inch photo?

$$\begin{array}{l}
 \text{lines} \\
 \text{Inches}
 \end{array}
 \quad
 \frac{80}{1} : \frac{x}{4.5} \quad x = 360 \text{ lines total}$$

$$\begin{array}{l}
 \text{lines} \\
 \text{Seconds}
 \end{array}
 \quad
 \frac{360}{x} : \frac{5}{1} \quad x = 72 \text{ seconds}$$

$$\begin{array}{l}
 \text{Seconds} \\
 \text{Minutes}
 \end{array}
 \quad
 \frac{60}{1} : \frac{72}{x} \quad x = 1.2 \text{ minutes}$$

For more practice and a more in-depth look at The Princeton Review math techniques, check out our student-friendly guidebook, Cracking the New GRE.

DRILL 1

Question 1

A certain recipe calls for 2 cups of sugar and $3\frac{1}{2}$ cups of flour. What is the ratio of sugar to flour in this recipe?

$\frac{3}{10}$

$\frac{2}{5}$

$\frac{4}{7}$

$\frac{4}{5}$

$\frac{6}{7}$

CHARITABLE ANNUAL DONATIONS TO CHARITY GROUP X

Employees of Company:	Years 1980–1990		Years 1980–2000	
	Average (mean) annual donation per employee	Greatest single annual donation by an employee	Average (mean) annual donation per employee	Greatest single annual donation by an employee
A	24.3	1,000	34.6	1,000
B	18.2	500	40.2	500
C	45.5	300	45.5	2,000
D	34.6	2,000	34.6	2,000
E	34.7	1,000	32.4	1,000
F	150.3	2,000	100.8	2,000
G	23.7	500	23.7	500
H	34.7	500	34.7	1,000
I	74.5	5,000	80.2	5,000
J	85.6	3,000	85.6	3,000
K	126.7	5,000	104.4	5,000
L	234.4	3,000	234.4	3,000
M	422.4	400	455.2	2,000

(Click [here](#) to view a larger image.)

What is the approximate ratio of Company F's average annual donation to charity group X for the period 1980–1990 to that for the period 1980–2000?

- 1:1
 3:2
 3:5
 3:40
 5:2

Question 3

If a certain vitamin pill has 400 milligrams of magnesium, then how many grams of magnesium are in a bottle of 500 vitamin pills? (1 gram = 1,000 milligrams)

- 20
 200
 2,000
 20,000
 200,000

Question 4

$a = \frac{1}{6}$ and $\frac{6}{7} = \frac{5}{b}$, what is the value of $a + b$?

- $\frac{71}{210}$

- 3
- $\frac{187}{42}$
- 6
- $\frac{47}{6}$

Question 5

James can swim 750 yards in 10 minutes. If he swims at the same constant rate, how many minutes will it take him to swim 4.2 times this distance?

Question 6

b is a multiple of positive integer a.

Quantity A

The ratio of a to b

Quantity B

$\frac{1}{2}$

- Quantity A is greater.
- Quantity B is greater.
- The two quantities are equal.
- The relationship cannot be determined from the information given.

Question 7

Keri, Neill, and Rich use toilet paper in their apartment in a ratio of 3:2:2. Rich buys two cases of toilet paper online for everyone's use at 28 rolls per case, an average of \$3.50/roll and a \$14 delivery charge. If they each contribute to the cost of the toilet paper in direct proportion to the amount they use, how much must Keri contribute?

Question 8

$$36a = 25b$$

$$ab \neq 0$$

Quantity A

$\frac{5}{6}$

Quantity B

$\frac{a}{b}$

- Quantity A is greater.
- Quantity B is greater.
- The two quantities are equal.
- The relationship cannot be determined from the information given.

Question 9

By volume, cranberry juice makes up 12.5 percent of Bee's punch and 25 percent of Flo's punch. If 3 liters of Bee's punch are mixed with 6 liters of Flo's punch, approximately what percent of the mixture, by volume, is cranberry juice?

Indicate all such ratios.

- 6.25%
- 18.75%
- 20.83%
- 33.33%
- 50.00%

Question 10

At the beginning of the day, the ratio of cats to dogs at a boarding kennel was 10 to 11. Throughout the day, 4 dogs and 5 cats were admitted to the boarding kennel and no animals were released.

Quantity A

The number of cats in the boarding kennel at the end of the day

Quantity B

The number of dogs in the boarding kennel at the end of the day

- Quantity A is greater.
- Quantity B is greater.
- The two quantities are equal.
- The relationship cannot be determined from the information given.

Question 11

If $7(a - 1) = 17(b - 1)$, and a and b are both positive integers the product of which is greater than 1, then what is the least possible sum of a and b ?

- 2
- 7
- 17
- 24
- 26

Question 12

A machine works at a constant rate and produces a bolts in 15 minutes and b bolts in c hours.

Quantity A

b

Quantity B

$3ac$

- Quantity A is greater.
- Quantity B is greater.
- The two quantities are equal.
- The relationship cannot be determined from the information given.

Question 13

On a fishing trip, Robert caught salmon and halibut in a ratio of 4:5. If Robert caught 12 salmon, how many total fish did he catch?

DRILL 2

Question 1

If a high school's varsity tennis team is made up of 24 juniors and seniors, which of the following could be the ratio of juniors to seniors on the team?

Indicate all such ratios.

- 1:2
- 1:3
- 1:4
- 1:5
- 3:5
- 3:8

Question 2

Ann wants to make cookies, but she only has 2 eggs and the recipe calls for 3. If the recipe calls for 3 cups of flour, 1 cup of sugar, and $\frac{1}{2}$ cup of butter, how many cups of butter will she need to use?

CHARITABLE ANNUAL DONATIONS TO CHARITY GROUP X

Employees of Company:	Years 1980–1990		Years 1980–2000	
	Average (mean) annual donation per employee	Greatest single annual donation by an employee	Average (mean) annual donation per employee	Greatest single annual donation by an employee
A	24.3	1,000	34.6	1,000
B	18.2	500	40.2	500
C	45.5	300	45.5	2,000
D	34.6	2,000	34.6	2,000
E	34.7	1,000	32.4	1,000
F	150.3	2,000	100.8	2,000
G	23.7	500	23.7	500
H	34.7	500	34.7	1,000
I	74.5	5,000	80.2	5,000
J	85.6	3,000	85.6	3,000
K	126.7	5,000	104.4	5,000
L	234.4	3,000	234.4	3,000
M	422.4	400	455.2	2,000

(Click [here](#) to view a larger image.)

Question 3

For any Company X listed in the chart above, let ΔX be defined as the difference between the mean annual donation of employees of Company X in the period 1980–1990 and that for the same company in the period 1980–2000. Which of the following is closest to the ratio of ΔM to ΔB ?

- 2 to 1
- 3 to 2
- 1 to 1
- 2 to 3
- 1 to 2

Question 4

If Company A had, on average, 15 times as many employees in the period 1980–2000 as did Company K, then which of the following is closest to the ratio of the actual donations from Company A in 1980–2000 to the actual donations from Company K in the same period?

- 1:3
- 1:2
- 3:1
- 4:1
- 5:1

Question 5

A jar contains only marbles of three different colors: red, green, and yellow. The red and green marbles are in a ratio of 2:5, and the yellow and red marbles are in a ratio of 5:6. Which of the following could be the total number of marbles?

- 13
- 24
- 52
- 90
- 134
- 182

Question 6

If the ratio of b to c is 35 to 4, and the ratio of a to c is 3 to 7, then what is the ratio of a to b?

- $\frac{3}{35}$
- $\frac{4}{35}$
- $\frac{1}{5}$
- $\frac{1}{4}$
- $\frac{7}{15}$

Question 7

Jenny's factory produces gear shafts at the rate of 250 gear shafts per hour. She finds that she is short 3000 gear shafts on an order that must be completed in the next 10 hours. By what percent must Jenny increase her rate of production, in gear shafts per hour, in order to complete the order on time?

Question 8

In one day, Juan sends Keith three times as many messages as he sends Laurence, and Laurence sends Missy 4.5 times as many messages as he receives from Juan. If Missy received 18 messages from Laurence, how many messages does Keith receive from Juan?

- 3
- 12
- 16
- 18
- 56

Question 9

If the smallest angle of a triangle measures 45 degrees, which of the following could be the ratio of the three angles of the triangle?

- 2:3:3
- 3:4:5
- 3:5:7
- 9:10:17

9:11:13

15:17:18

Question 10

If $\frac{a}{b} = \frac{11}{6}$ and $\frac{b}{c} = \frac{4}{3}$, then what is the ratio of a to c ?

Question 11

Mariko can knit 5 rows of a scarf in x minutes. If there are 100 rows in each foot of the scarf, how many hours, in terms of x and y, will it take Mariko to finish a scarf that is y feet long?

$\frac{xy}{3}$

$\frac{1200}{xy}$

1200xy

$\frac{3}{xy}$

3xy

Question 12

If Elier can bake c cakes in h hours, then at this rate how many hours will it take him to bake 777 cakes?

777ch

$\frac{777h}{c}$

$\frac{h}{777c}$

$\frac{777c}{h}$

$\frac{c}{777h}$

Question 13

A 60 ounce package of trail mix contains x ounces of raisins, x + 8 ounces of peanuts, and 32 ounces of granola. If the ratio of peanuts to granola is 9:16, what is the value of x ?

ANSWERS

Drill 1

1. C
2. B
3. B
4. D
5. 42
6. D
7. 90
8. A
9. C
10. D
11. E
12. A
13. 27

Drill 2

1. A, B, D, E
2. $1/3$
3. B
4. E
5. C, F
6. B
7. 20
8. B
9. A, B, D
10. $22/9$
11. A
12. B
13. 10

Drill 1

1. C A ratio is a part-to-part relationship, but it can be expressed and manipulated just like a fraction—in this case, $\frac{3}{3\frac{1}{2}}$. None of the answers have a fractional value in the denominator, so you need to find a multiplier that will get rid of the fraction. In this case, just doubling the entire ratio will do the trick: $\frac{3}{3\frac{1}{2}} \times \frac{2}{2} = \frac{4}{7}$.
2. B Read the chart carefully and then ballpark. Company F's annual average donation was about 150 for 1980–1990 and about 100 for 1980–2000. Reduce 150:100 to 3:2.
3. B First, find that 400 milligrams \times 500 pills = 200,000 milligrams total. Then, convert to grams by dividing by 1,000 to find the answer: 200 grams. When doing multiple conversions, be sure to label carefully and watch for arithmetic errors.
4. D Cross-multiply to find the value of b, $\frac{35}{6}$. Then substitute in the values of a and b: $a + b = \frac{1}{6} + \frac{35}{6} = \frac{36}{6} = 6$
5. 42 To swim 4.2 times the original distance, James needs to swim for 4.2 times the original time. Multiply the original time of 10 minutes by 4.2 to get 42, the correct answer.
6. D Because you have variables, make your set-up on your scratch paper. Plug in different values for a and b. First, try 2 and 4: $\frac{2}{4}$ reduces to $\frac{1}{2}$, making the quantities equal. Eliminate choices (A) and (B). Next, try 2 and 6. $\frac{2}{6}$ reduces to $\frac{1}{3}$, which is less than $\frac{1}{2}$. Quantity B is now greater, so eliminate choice (C). You're left with choice (D).
7. 90 The three roommates spend a total of \$210 on toilet paper. If you make your ratio box you will see that your ratio total is 7 and your actual total is 210, so your multiplier is 30. Keri therefore needs to contribute \$90.00 to the cost of the toilet paper.
8. A Divide both sides by b, then divide both sides by 36 to find: $\frac{a}{b} = \frac{25}{36}$. Although $\frac{5}{6} \times \frac{5}{6} = \frac{25}{36}$, this does not mean that $\frac{25}{36}$ reduces to $\frac{5}{6}$. Use the Bowtie to compare the two fractions: 36 times 5 equals 180, while 6 times 25 equals 150. 180 is bigger, so Quantity A is greater.
9. C Estimate to solve this one. The answer must be between 12.5 percent and 25 percent because you are mixing two punches with these percentages—eliminate all choices except choices (B) and (C). Because there is more of Flo's punch, the answer must be closer to 25 percent than to 12.5 percent, so choice (C) is correct.
10. D Try Plugging In. If there are 10 cats at the beginning of the day, then there are 11 dogs; at the end of the day, there would be 15 cats and 15 dogs. In this case, Quantity A and Quantity B are equal. Eliminate choices (A) and (B). However, there could be 20 cats and 22 dogs at the beginning of the day; then there would be 25 cats and 26 dogs at the end of the day. In that situation, Quantity B is greater; eliminate choice (C). Only choice (D) remains.
11. E Because 7 and 17 are prime and have no common factor greater than 1, their least common multiple will be their product: $7 \times 17 = 119$. The least possible value for (a – 1), then, is 17, so a = 18; likewise, the least possible value for (b – 1) is 7, so b = 8. The least possible sum for a and b, therefore, is $18 + 8 = 26$. Be careful if you selected choice (A): Although Plugging In a value of 1 for both a and b would yield 0 on both sides of the equation, the problem specifies that the product of a and b be greater than 1.
12. A Plug in values. If a = 5 and c = 1, then b = 20. In that situation Quantity A is larger; eliminate choices (B) and (C). Plug In again to see if this is always the case. If a = 100 and c = 2, then b = 800. Quantity A is still larger. There isn't anything else you can try that would change the values, so choice (A) is the best answer.
13. 27 Make a ratio box and fill in what you know: the ratio and the total number of salmon. You then total number of fish in the ratio row, and find your multiplier in the salmon column. Multiply down to figure out the actual total number of fish, which is 27.

Salmon	Halibut	Total
4	5	9
3	3	3
12	15	27

1. A, B, D, and E

Set up your ratio box. The number given is the actual total number of players, so put 24 there. Then start Plugging In the Answers into your ratio row to see which could work. The ratio of 1:2 in choice (A) would yield a ratio total of 3; this works with a multiplier of 8, so you know choice (A) works. Choice (B) gives a ratio total of 4, which would work with a multiplier of 6; choice (B) works. Choice (C), however, gives a ratio total of 5; since 24 isn't a multiple of 5, it would yield a fractional multiplier, and thus fractional juniors and seniors. Eliminate choice (C). Choices (D) and (E) would work with multipliers of 4 and 3, respectively. Choice (F) yields a ratio total of 11, which will again yield a fractional multiplier, so eliminate choice (F).

2. $\frac{1}{3}$ Set up a ratio box. Put the recipe's original ratio of ingredients in the top row and start with 2 eggs in the "actual" row. This makes your multiplier $\frac{2}{3}$. Fill out the rest of the ratio box to determine the number of cups of butter.

Flour	Sugar	Butter	Eggs	Total
3	1	$\frac{1}{2}$	3	
$\frac{2}{3}$	$\frac{2}{3}$	$\frac{2}{3}$	$\frac{2}{3}$	
2	$\frac{2}{3}$	$\frac{1}{3}$	2	

3. B According to the given definition, ΔM is $455.2 - 422.4 = 32.8$, and ΔB is $40.2 - 18.2 = 22$. Round ΔM to 33, and the ratio of ΔM to ΔB is 33 to 22, which reduces to 3 to 2. Choice (B) is correct.
4. E To simplify this problem, ignore the chart column about the greatest single employee donation and plug in easy values for the number of employees for each company. Try 15 employees for Company A and 1 employee for Company K: Now you have a total donation of $15 \times 34.6 = 519$ per year from Company A, and a total donation of 104.4 per year from the single employee of Company K. The ratio is thus 519:104.4, which reduces almost exactly to 5:1, so choice (E) is correct. If you selected choice (A), you may have solved for the averages rather than the actual amount of the donations; if you selected choice (D), you may have solved for the period 1980–1990.
5. C and F Since red is common to the given ratios, you'll want to multiply the red:green ratio by 3 so that red is 6 in both. Now you can put it all together in one ratio—red:green:yellow = 6:15:5. More importantly, you can put them in one Ratio Box:

Red	Green	Yellow	Total
6	15	5	26

No need to finish the rest of the Ratio Box—you have all you need. Look for answer choices that are multiples of 26. Only choices (C) and (F) work.

6. B When you need to compare ratios, think of the ratios as fractions that need common denominators. The value of c in each ratio will need to become 28, and the other values will need to change accordingly. That will make $b:c = 105:28$ after multiplying the original values by 7, and $a:c = 12:28$ after multiplying the original values by 4. This means $a:b = 12:105$. Simplify, and you get 4:35.
7. 20 Jenny must complete 3000 gear shafts in 10 hours, which is a rate of 300 gear shafts per hour. Percent change is $\left(\frac{\text{difference}}{\text{original}}\right) \times 100$.

In this case, the difference is 50 and the original is 250, so the percent change is $\left(\frac{50}{250}\right) \times 100 = 20$. The question asks for percent

increase, so be sure to enter 20, and not 0.2.

8. B It's an algebra question with numbers for answer choices, so set up your scratch paper to plug in the answers. The answers represent the number of messages Keith receives from Juan, so label them K , or something similar, and give yourself columns for L , which is $K \div 3$, and M , which is $4.5 \times L$. Start with choice (C). If $K = 16$, then L is a fraction; since you can send a fractional message, eliminate choice (C)—and go ahead and eliminate choice (E), since it's also not divisible by 3. Next, try choice (B), since it's the middle of the remaining 3 answer choices. If $K = 12$, then $L = 4$ and $M = 18$. That's the correct number of messages for Missy, so choice (B) is

correct.

9. A, B, D, and F
For each choice, use a ratio box. The first part of each ratio represents 45 degrees. For choice (A), the multiplier will be 45 divided by 2, or 22.5. The ratio adds up to 8 ($2 + 3 + 3$), so check that $8 \times 22.5 = 180$. It does, so choice (A) works. For choice (B), based on 3 representing 45 degrees, the multiplier is 15. The ratio adds up to 12, and $12 \times 15 = 180$, so this choice works as well. Using this approach, choice (C) does not work: The multiplier is again 15, but 15×15 does not equal 180. Choice (D) works, with a multiplier of 5: $5 \times 36 = 180$. When you test the remaining two choices, neither one produces the 180 degrees you need for the triangle, so eliminate them.
10. $\frac{22}{9}$ The common element between both proportions is b, so that's what you'll want to start with. However, the numerical value of b does not match from proportion to proportion, so you'll essentially want to find a common multiple for both values of b. Both 4 and 6 are factors of 12, so use 12 as your common multiple. For the first proportion, you'll need to double it in order to make $b = 12$. When you do so, $a = 22$. For the second proportion, you'll need to triple it to make $b = 12$. Therefore, $c = 9$. Now that the two proportions have the same value for b, you know that a:c equals 22:9, which can be written as a fraction.
11. A As soon as you see variables in the answer choices, set up your scratch paper to Plug In. Start with $x = 5$, so it takes 1 minute to knit 1 row. Now make $y = 2$. A scarf 2 feet long means Mariko has to knit 200 rows, which will take 200 minutes; since the problem asks how many hours it will take, your target answer is $\frac{200}{60} = 3\frac{1}{3}$. Now plug your values into the answer choices; only choice (A) hits your target. Choices (C) and (E) are clearly too small, and choice (D) is a fraction, so you may not have to calculate all the choices.
12. B Plug in your own numbers for c and h. Let's say Elier can bake 14 cakes in 2 hours; this makes $c = 14$ and $h = 2$. That means he can bake 7 cakes per hour. At this rate, it will take him 111 hours to bake 777 cakes. Circle 111 as your target number. When you plug in your values, choices (A) and (D) are way too big. Choices (C) and (E) are way too small. Using your calculator, you can determine that choice (B) matches.
13. 10 Here's the ratio box you can set up. From the ratio with the granola and the actual ounces of granola provided you can solve for the multiplier, which is 2.

Raisins	Peanuts	Granola	Total
?	9	16	30
2	2	2	2
x	$x + 8$	32	60

Multiplying vertically, the number of peanuts is 18. You have $18 = x + 8$, so $x = 10$.



Exponents and Square Roots

EXPONENTS AND SQUARE ROOTS

For some reason, exponents and square roots always look scary; maybe it's the funny little symbols. ETS has a real gift for making them look challenging, but they are all based on the same set of basic rules.

EXPONENTS

If you see a^2 , it simply means $a \times a$. If you see a^3 , it means $a \times a \times a$, and so on. Hence, the golden rule of exponents is

When in doubt, expand it out.

x^2 times x^3 equals x^5 , because

$$x^2 \cdot x^3 = (x \cdot x)(x \cdot x \cdot x) = x^{2+3} = x^5$$

When you multiply numbers raised to powers, simply add the exponents.

You can continue this logic when you are dividing exponents.

$\frac{x^2}{x^3}$ equals $\frac{1}{x}$, because expanding out and canceling leaves you with only one x in the divisor.

$$\frac{x^2}{x^3} = \frac{x \cdot x}{x \cdot x \cdot x} = \frac{\cancel{x} \cdot \cancel{x}}{\cancel{x} \cdot \cancel{x} \cdot x} = \frac{1}{x} = x^{2-3} = x^{-1}$$

When you divide numbers raised to powers, simply subtract the exponents. Thus, x^{2-3} equals x^{-1} which is the same thing as $\frac{1}{x}$.

This same rule applies to exponents and parentheses as well.

$$(x^2)^3 = (x \cdot x)(x \cdot x)(x \cdot x) = x^{2 \cdot 3} = x^6$$

When you raise a number with a power to another power, simply multiply the exponents.

The one thing to remember with an exponent outside of a parenthesis is that the exponent applies to everything inside the parenthesis. Thus:

$$\left(\frac{2}{5}\right)^2 = \frac{4}{25} \text{ and } (4x)^2 = 16x^2.$$

Adding and Subtracting Large Exponents

If you see a problem that asks you to add or subtract large exponents, look for an opportunity to factor. This is particularly true on Quant Comp problems. Often, you don't need to solve; you just need to make the two columns look similar.

Here's an example:

<u>Quantity A</u>	<u>Quantity B</u>
$\frac{3^{30} - 3^{28}}{2^3}$	3^{28}

Quantity A involves the subtraction of two large exponents. Quantity B has a large exponent suspiciously similar to the ones in Quantity A. When a question like this appears, you know two things right away. First, you will never be asked to figure out the actual value of 3^{30} . The answer to this problem will come from knowledge and manipulation, not from calculation. Second, the number in Quantity B is a clue: 3^{28} exists in both columns. Your strategy is to isolate the information that is the same in both columns and examine the information that is different.

When large exponents are added or subtracted, look for opportunities to factor.

Start by trying to isolate the 3^{28} in Quantity A.

Here's what happens:

$$\frac{3^{30} - 3^{28}}{2^3} = \frac{3^{28}(3^2 - 1)}{2^3} = \frac{3^{28}(9 - 1)}{2^3} = \frac{3^{28}(\cancel{8})}{\cancel{8}} = 3^{28}$$

When you factor 3^{28} out of the expression on top, you are left with 3^2 minus 1. This you can solve; it equals 8. Low and behold, there is an 8

Exponent Rules

Here are some other things to keep in mind about exponents.

- Any number raised to the zero power equals one.
- Any number raised to the first power is itself.
- A negative number raised to an even power is positive.
- A negative number raised to an odd power is negative.
- Fractions less than one raised to higher powers get smaller; the higher the power, the smaller they get.

SQUARE ROOTS

Square roots are the same thing as exponents, but in reverse. Rather than making things exponentially larger, square roots make them exponentially smaller. There's not much you can do with square roots. You can add them or subtract them only when the roots are the same; thus $\sqrt{3} + \sqrt{3} = 2\sqrt{3}$ because now there are two of them. When the roots are different, though, you can't add or subtract them.

When you are multiplying square roots, you can combine things under a single symbol.

$$\sqrt{4} \times \sqrt{16} = \sqrt{4 \times 16} = \sqrt{64} = 8$$

You can also combine when dividing.

$$\frac{\sqrt{64}}{\sqrt{4}} = \sqrt{\frac{64}{4}} = \sqrt{16} = 4$$

Remember that even if the number under a square root sign is not a perfect square, it doesn't mean that there aren't some perfect squares in there. These you can factor out. For example, there is no even square root of 12, but 12 is a product of three and four. Three has no even square root, so it must stay under the sign. Four is a perfect square, though; you can take it out from under the sign and call it two.

$$\sqrt{12} = \sqrt{3 \times 4} = \sqrt{3} \times \sqrt{4} = \sqrt{3} \times 2 = 2\sqrt{3}$$

Remember that $2\sqrt{3}$ means two times the square root of three.

Negative Squares

There is one tricky thing about square roots: negative numbers. When you square 3, you get 9, but when you square -3, you also get 9. That means that when you're going in the other direction, you have two possible answers. Thus, if you're told that $x^2 = 9$, then $x = \pm 3$. However, on the GRE, the square root of a number is defined as the positive root only, so $\sqrt{9}$ equals 3, not ± 3 .

A square root only has a positive solution, but an exponent to the 2nd power has both a positive and a negative solution.

For more practice and a more in-depth look at The Princeton Review math techniques, check out our student-friendly guidebook, *Cracking the New GRE*.

DRILL 1
Question 1

$$a < 0$$

Quantity A

$$a^2$$

Quantity B

$$2a$$

- Quantity A is greater.
- Quantity B is greater.
- The two quantities are equal.
- The relationship cannot be determined from the information given.

Question 2

$$8z^4 = 96$$

Quantity A

$$2$$

Quantity B

$$z$$

- Quantity A is greater.
- Quantity B is greater.
- The two quantities are equal.
- The relationship cannot be determined from the information given.

Question 3

What is the value of $3^{3a} - 2$ when $a = 2$?

- 16
- 52
- 79
- 697
- 727

Question 4

Quantity A

$$x + y$$

Quantity B

$$(x + y)^2$$

- Quantity A is greater.
- Quantity B is greater.
- The two quantities are equal.
- The relationship cannot be determined from the information given.

Quantity A

$$\frac{5^{15}}{5^5}$$

Quantity B

$$\frac{5^{18}}{5^6}$$

- Quantity A is greater.
- Quantity B is greater.
- The two quantities are equal.
- The relationship cannot be determined from the information given.

Question 6

What is the value of $\sqrt{\sqrt{64}}$?

- $2\sqrt{2}$
- 4
- $4\sqrt{2}$
- 16
- 32

Question 7

Quantity A

$$(0.5)^3$$

Quantity B

$$\left(5\right)^3 \left(\frac{1}{2}\right)^3 \left(\frac{1}{5}\right)^3$$

- Quantity A is greater.
- Quantity B is greater.
- The two quantities are equal.
- The relationship cannot be determined from the information given.

Question 8

$$\sqrt{81+9} =$$

- 9
- 10
- $3\sqrt{10}$
- 12
- 30

Question 9

$$x > 0$$

Quantity A

Quantity B

$$\left(\frac{1}{3}\right)^x$$

$$\left(-\frac{1}{2}\right)^x$$

- Quantity A is greater.
- Quantity B is greater.
- The two quantities are equal.
- The relationship cannot be determined from the information given.

Question 10

Quantity A

$$-\sqrt{9}$$

Quantity B

$$\sqrt[3]{-27}$$

- Quantity A is greater.
- Quantity B is greater.
- The two quantities are equal.
- The relationship cannot be determined from the information given.

Question 11

What is the value of $\sqrt[3]{69}$ approximated to the nearest integer?

- 13
- 8
- 5
- 4
- 3

DRILL 2
Question 1

$$y > 0$$

Quantity A

$$\left(\frac{2}{y}\right)^3$$

Quantity B

$$\left(\frac{3}{y}\right)^2$$

- Quantity A is greater.
- Quantity B is greater.
- The two quantities are equal.
- The relationship cannot be determined from the information given.

Question 2

$$\left(\frac{1}{2}\right)^3 + \left(\frac{2}{3}\right)^2 + \left(\frac{1}{6}\right)^1 =$$

- $\frac{1}{6}$
- $\frac{1}{18}$
- $\frac{5}{36}$
- $\frac{53}{72}$
- $\frac{8}{6}$

Question 3

$$\frac{9^2 - 3^2}{6^2} =$$

- $\frac{1}{2}$
- 1
- 2
- 4
- 6

Question 4

Quantity A

$$\sqrt{\frac{1}{4^2}}$$

Quantity B

$$\frac{1}{4}$$

- Quantity B is greater.
- The two quantities are equal.
- The relationship cannot be determined from the information given.

Question 5

Quantity A

$$(x^3 + 1)^2$$

Quantity B

$$x^6$$

- Quantity A is greater.
- Quantity B is greater.
- The two quantities are equal.
- The relationship cannot be determined from the information given.

Question 6

$$(\sqrt{5} + \sqrt{7})^2 =$$

- 12
- $12 + 2\sqrt{3}$
- $12 + 4\sqrt{3}$
- $12 + \sqrt{35}$
- $12 + 2\sqrt{35}$

Question 7

If $\sqrt{x} = 4$, then $x^2 =$

- 2
- 4
- 8
- 16
- 256

Question 8

What is the value of $x^2 - 1$ when $9^x + 1 = 27^{x-1}$?

Question 9

Quantity A

$$(y - x)^7(y - x)^2$$

Quantity B

- Quantity B is greater.
- The two quantities are equal.
- The relationship cannot be determined from the information given.

Question 10

Quantity A

$$2^2(420)$$

Quantity B

$$2^5(105)$$

- Quantity A is greater.
- Quantity B is greater.
- The two quantities are equal.
- The relationship cannot be determined from the information given.

Question 11

If $b = \frac{c + d^2}{c}$ and $a = \frac{c}{d^2}$, what is b in terms of a ?

- $1 + \frac{1}{a}$
- $1 + a$
- $\frac{1}{1 + a}$
- $a^2 + 1$
- $\frac{a}{a + 1}$

DRILL 3

Question 1

If $-1 < a < 0$, $q = a - 1$, $r = a^2$, and $s = a^3$, then which of the following is true?

- $q < r < s$
- $q < s < r$
- $r < q < s$
- $s < q < r$
- $s < r < q$

Question 2

$$\sqrt{10y} = 5$$

$$z^4 = 81$$

Quantity A

z

Quantity B

y

- Quantity A is greater.
- Quantity B is greater.
- The two quantities are equal.
- The relationship cannot be determined from the information given.

Question 3

0.1 is how many times greater than $(0.01)^3$?

- 10^6
- 10^5
- 10^4
- 10^3
- 10^2

Question 4

If $x \geq 0$, then $\sqrt{0.49x^{16}}$ must be equal to

- $0.07x^8$
- $0.07x^4$
- $0.7x^{14}$
- $0.7x^8$
- $0.7x^4$

Quantity A de Quantity B \sqrt{de}

- Quantity A is greater.
- Quantity B is greater.
- The two quantities are equal.
- The relationship cannot be determined from the information given.

Question 6

If $m > 0$ and $n > 0$, which of the following is equivalent to $\frac{nm}{m^2} \sqrt{\frac{m^2}{n}}$?

- \sqrt{n}
- $\frac{nm}{\sqrt{n}}$
- $\frac{m^2}{n}$
- $\frac{n^2}{m}$
- $\frac{1}{nm}$

Question 7

Quantity A 20^7 Quantity B $\left(\frac{4^{13}}{4^6}\right)(5^4 \times 5^3)$

- Quantity A is greater.
- Quantity B is greater.
- The two quantities are equal.
- The relationship cannot be determined from the information given.

Question 8

Quantity A $0.8^2 + 0.8^2 + 0.8^2 + 0.8^2 1.6^2$ Quantity B 1.6^2

- Quantity A is greater.
- Quantity B is greater.
- The two quantities are equal.
- The relationship cannot be determined from the information given.

Which expression is equivalent to $\frac{2 - \sqrt{3}}{2 + \sqrt{3}}$?

- $-\frac{1}{5}$
- -1
- $\frac{4\sqrt{3} - 1}{7}$
- $4\sqrt{3} - 7$
- $7 - 4\sqrt{3}$

Question 10

b is an integer, and $0 \leq b \leq 2$

Quantity A

$$\left(b^2 + \frac{1}{2}\right)^b$$

Quantity B

$$20 + \frac{1}{4}$$

- Quantity A is greater.
- Quantity B is greater.
- The two quantities are equal.
- The relationship cannot be determined from the information given.

Question 11

$$ab = 12$$

$$b^2 = 16$$

Quantity A

a

Quantity B

b

- Quantity A is greater.
- Quantity B is greater.
- The two quantities are equal.
- The relationship cannot be determined from the information given.

DRILL 4
Question 1

$$(x + y)(x - y) = 0$$

$$xy \neq 0$$

Quantity A

$$6\sqrt{\frac{19}{2x^2}}$$

Quantity B

$$\sqrt{\frac{342}{y^2}}$$

- Quantity A is greater.
- Quantity B is greater.
- The two quantities are equal.
- The relationship cannot be determined from the information given.

Question 2

$$\sqrt{25 + 25 + 100} =$$

- $5\sqrt{5}$
- $5\sqrt{6}$
- 15
- 20
- $75\sqrt{2}$

Question 3

If $x < 1$, then 1^x could equal

- 0
- $\frac{1}{4}$
- $\frac{1}{2}$
- 1

Question 4

$$\sqrt[3]{8 \times 27 \times 64} =$$

Question 5

If $\frac{x}{12} = 2^{-5} \times 4^{\frac{1}{2}}$ then $x =$

If $\frac{8^r}{4^s} = 2^t$, then what is r in terms of s and t ?

- s + t + 1
- s + t + 5
- $\frac{2s + t}{3}$
- $\frac{2st}{3}$
- $\frac{s}{2} + \frac{t}{4}$

Question 7

What is y if $9^3 = 3^{2y} + 5$?

Question 8

If $72^4 = (16)(6^n)$, what is the value of n?

Question 9

$$(\sqrt{245} - \sqrt{75})^2 =$$

- $170 - 170 - 5\sqrt{8}$
- $170 - 170 - 70\sqrt{15}$
- $320 - 320 - 70\sqrt{15}$
- $318 - 318 - 35\sqrt{15}$
- 170

Question 10

If $x^2 - x\sqrt{2} + 3x\sqrt{3} = \sqrt{54}$ then x =
Indicate all possible values.

- $-\sqrt{2}$
- $-3\sqrt{2}$
- $-3\sqrt{3}$
- $\sqrt{2}$

Question 11

$$\text{If } 3\sqrt{\frac{x^{\frac{3}{4}}}{x^{\frac{13}{4}}}} = (x^{\frac{1}{4}} \cdot x^{\frac{5}{4}})^2 \text{ then } x =$$

DRILL 5
Question 1

$$y \neq 0$$

Quantity A

$$\frac{-y^3}{2}$$

Quantity B

$$\frac{y^2}{2}$$

- Quantity A is greater.
- Quantity B is greater.
- The two quantities are equal.
- The relationship cannot be determined from the information given.

Question 2

Which of the following is equal to $(\sqrt[3]{64} + \sqrt[3]{8})^2$?

- 6
- 20
- 36
- 64
- 100

Question 3

Which of the following expressions is equivalent to 17,640?
Indicate all such expressions.

- $2^3 \times 3^2 \times 5 \times 7^2$
- $2^3 \times 3^2 \times 7^2 \times 11$
- $(2 \times 3 \times 7)^2 \times 10$
- $5 \times 7 \times 7 \times 8 \times 9$
- $7 \times 7 \times 8 \times 9 \times 11$

Question 4

If $\sqrt[3]{x+3} = 4$, $x =$

Question 5

If $p \neq 0$, and $\frac{1}{p} = \sqrt{q}$, what is the value of p ?

- q
- \sqrt{q}

$\frac{\sqrt{q}}{q}$

$\frac{1}{q}$

$\frac{1}{q^2}$

Question 6

If j is a nonzero integer, which of the following must be greater than j ?
Indicate all possible values.

j^{-2}

j^{-1}

j^0

j^2

j^3

j^4

Question 7

$$(\sqrt{79} - 1)(\sqrt{79} + 1)(\sqrt{78} - 1)(\sqrt{78} + 1) =$$

Question 8

An empty, cube-shaped swimming pool is filled part way with x cubic feet of water. It is then filled the rest of the way with y cubic feet of chlorine. Which of the following, in feet, expresses the depth of the swimming pool?

$x + y$

$\frac{x + y}{3}$

$\sqrt[3]{x + y}$

$(x + y)^3$

$\frac{\sqrt[3]{x + y}}{3}$

Question 9

$$\frac{81^3 - 27^3}{3^7}$$

Question 10

For which of the following values of x is $\frac{4^x}{x^4}$ an integer?

Indicate all possible values.

2

- 3
- 4
- 5
- 6
- 7
- 8

ANSWERS

Drill 1

1. A
2. A
3. E
4. D
5. B
6. A
7. C
8. C
9. D
10. C
11. D

Drill 2

1. D
2. D
3. C
4. C
5. D
6. E
7. E
8. 24
9. D
10. B
11. A

Drill 3

1. B
2. D
3. B
4. D
5. D
6. A
7. C
8. C
9. E
10. D
11. D

Drill 4

1. C
2. B
3. D
4. 24
5. $\frac{3}{4}$ or any equivalent value, such as $\frac{6}{8}$, $\frac{9}{12}$, $\frac{12}{16}$, etc.
6. C
7. $\frac{1}{2}$
8. 8
9. C
10. C, D
11. 3

Drill 5

1. D
2. C
3. A, C, D
4. 61
5. C
6. D, F
7. 6006
8. C
9. 234
10. A, C, G

Drill 1

- A Try Plugging In. If $a = -3$, then Quantity A is $(-3)^2 = 9$ and Quantity B is $2(-3) = -6$. Notice that Quantity A must always be positive because anything raised to an even power is positive. Quantity B must be negative because a positive times a negative is always negative. Thus, Quantity A must always be greater.
- A Divide both sides by 8 to get $z^4 = 12$. Rather than finding the fourth root of 12, try plugging in 2 for z : $2^4 = 16$, so z must be less than 2. Of course, z may be negative, but any negative number is also less than 2.
- E Plug in 2 for a to find $3^{3(2)} - 2$ or $3^6 - 2$. When in doubt, expand it out. So, $(3 \times 3 \times 3 \times 3 \times 3 \times 3) - 2 = 729 - 2 = 727$.
- D Plug In! If $x = 2$ and $y = 3$, then Quantity A is 5 and Quantity B is 25. Quantity B is greater, so eliminate choices (A) and (C). Next, make x and y both 0. Both Quantities A and B are now 0, thus, they are equal. Eliminate choice (B), and you're left with choice (D).
- B Simplify each of the expressions by subtracting the exponents. You get 5^{10} in Quantity A and 5^{12} in Quantity B.
- A First, take the square root of 64, which is 8. $\sqrt{8} = \sqrt{4} \times \sqrt{2} = 2\sqrt{2}$. Choice (A) is correct.
- C Quantity A, $(0.5)^3$, equals 0.125. Quantity B, $(5)^3 \left(\frac{1}{2}\right)^3 \left(\frac{1}{5}\right)^3$, equals $(125) \left(\frac{1}{8}\right) \left(\frac{1}{125}\right)$; the first and third terms cancel to leave only $\frac{1}{8} = 0.125$. The quantities are equal. Alternatively, if you're comfortable with your exponent rules, you can combine and cancel the terms in Quantity B, and compare the quantities without calculating either one: $(5)^3 \left(\frac{1}{2}\right)^3 \left(\frac{1}{5}\right)^3 = \left(5 \times \frac{1}{2} \times \frac{1}{5}\right)^3$. Again, the first and third terms cancel to leave only $\left(\frac{1}{2}\right)^3$, which is the same as $(0.5)^3$.
- C First, add the numbers under the root symbol. To simplify $\sqrt{90}$ factor out the perfect square 9. $\sqrt{90} = \sqrt{9} \times \sqrt{10} = 3\sqrt{10}$. The answer is choice (C).
- D Evaluate the relationship between the quantities by plugging in values for x . If $x = 2$, then Quantity A is $\frac{1}{9}$ and Quantity B is $\frac{1}{4}$; Quantity B is greater, so eliminate answer choices (A) and (C). Now, if $x = 3$, then Quantity A is $\frac{1}{27}$ and Quantity B is $-\frac{1}{8}$; Quantity A is now greater, so eliminate choice (B), and you're left with choice (D).
- C In Quantity A, evaluate the root first, then attach the minus sign: $-\sqrt{9} = -3$; this is equivalent to Quantity B: $\sqrt[3]{-27} = -3$. Thus, the answer is choice (C).
- D $\sqrt[3]{69}$ means "the number that when you cube it, gives you 69". So plug in the answer choices, cubing each one until you find the value closest to 69. It is easier to start with the smaller values first. $3^3 = 27$; $4^3 = 64$; $5^3 = 125$. Clearly, 4^3 is closest to 69, so the answer is choice (D).

1. D Plug in values for y . If $y = 1$, then Quantity A is 8 and Quantity B is 9. In this case, Quantity B is larger, so eliminate choices (A) and (C). If $\frac{1}{2}$, then Quantity A is 64 and Quantity B is 36; eliminate choice (B). You are left with choice (D).
2. D First, use the exponent rules to find the values you need to add:
 $\left(\frac{1}{2}\right)^3 + \left(\frac{2}{3}\right)^2 + \left(\frac{1}{6}\right)^1 = \frac{1^3}{2^3} + \frac{2^2}{3^2} + \frac{1^1}{6^1} = \frac{1}{8} + \frac{4}{9} + \frac{1}{6}$. Then, because you have so many types of fractions, convert them all to the common denominator of 72: $\frac{9}{72} + \frac{32}{72} + \frac{12}{72} = \frac{53}{72}$. The answer is choice (D).
3. C Although it may be tempting to try some fancy factoring, this problem is more easily solved by calculating the individual exponential expressions: $\frac{9^2 - 3^2}{6^2} = \frac{81 - 9}{36} = \frac{72}{36} = 2$. Be careful if you got choice (B): You may have incorrectly subtracted $9^2 - 3^2$ in the numerator and gotten 6^2 .
4. C Simplify Quantity A: $\sqrt{\frac{1}{4^2}} = \frac{\sqrt{1}}{\sqrt{4^2}} = \frac{1}{4}$. The answer is choice (C).
5. D Plug in a value for x ; you're dealing with exponents, so keep your numbers small. If $x = 0$, then Quantity A is greater, so eliminate choices (B) and (C). If $x = -1$, though, then Quantity A = 0; Quantity B is now greater, so eliminate choice (A), and you're left with choice (D).
6. E You could use the common quadratic pattern $(x + y)^2 = x^2 + 2xy + y^2$. So, $(\sqrt{5} + \sqrt{7})^2 = \sqrt{5}^2 + 2$
 $\sqrt{5 \times 7} + \sqrt{7}^2 = 5 + 2\sqrt{35} + 7 = 12 + 2\sqrt{35}$. The answer is choice (E). Alternatively, you can just FOIL it. So,
 $(\sqrt{5} + \sqrt{7})^2 = (\sqrt{5} + \sqrt{7})(\sqrt{5} + \sqrt{7}) = 5 + \sqrt{5 \times 7} + \sqrt{5 \times 7} + 7 = 12 + 2\sqrt{35}$.
7. E First, square both sides of the equation to get $x = 16$. Then, square both sides of the equation again to get $x^2 = 256$. The answer is choice (E).
8. 24 Start by expressing both terms in the original equation as powers of 3: $9^x + 1 = 27^x - 1$ becomes $(3^2)^{x+1} = (3^3)^x - 1$. To raise a power to another power, multiply the exponents, so your equation becomes $3^{2x+2} = 3^{3x-3}$. Now that the bases are the same, set the exponents equal to each other and solve for x : $2x + 2 = 3x - 3$, so $x = 5$. Finally, remember to enter the correct value: The problem asks for $x^2 - 1$, so $5^2 - 1 = 25 - 1 = 24$.
9. D Try plugging in values for x and y . If $x = 1$ and $y = 3$, then Quantity A is 2^7 and Quantity B is 2^2 . Quantity A is greater, so eliminate choices (B) and (C). Then try $x = 1$ and $y = 1$; now both quantities are equal, so eliminate choice (A) and select choice (D).
10. B Compare the quantities, looking for ways that the numbers in one quantity can be rewritten using the numbers from the other quantity. In Quantity A, rewrite 420 as 4×105 . The 105 values cancel out, and the remaining multiples of 2 also cancel except for one 2 left in Quantity B. Choice (B) is correct.
11. A Plug in for c and d , in both equations, and solve for a and b . If $c = 8$ and $d = 4$, then $a = \frac{1}{2}$ and $b = 3$, your target answer. Now plug in $\frac{1}{2}$ for a in the answer choices; only choice (A) hits your target answer of 3.

1. B Plug In to solve this one, but don't forget your restrictions. If $a = -\frac{1}{2}$, then $q = -\frac{3}{2}$, $r = \frac{1}{4}$, and $s = -\frac{1}{8}$. Only choice (B) lists the values in the correct order.
2. D To find y , square both sides of the given equation: If $\sqrt{10y} = 5$, then $(\sqrt{10y})^2 = 5^2$, so $10y = 25$, and $y = 2.5$. To find z , do the opposite and take the square root of both sides of the given equation: If $z^4 = 81$, then $\sqrt{z^4} = \sqrt{81}$, so $z^2 = 9$, and $z = 3$ [eliminate choices (B) and (C)] or $z = -3$ [eliminate choice (A)]. The answer is choice (D).
3. B First, change the decimal at the end of the question to .000001. Next, set up your equation: $.01 = .000001x$. Then, use your calculator to carefully solve for $x = 100,000$. Choice (B) is correct.
4. D The term under the radical is a product, so you can separate the number and the variable $\sqrt{0.49x^{16}} = \sqrt{0.49} \times \sqrt{x^{16}}$. Just as the square root of 49 is 7, $\sqrt{0.49} = 0.7$; eliminate choices (A) and (B). Next convert $\sqrt{x^{16}}$ to $\sqrt{(x^8)^2}$; the radical and the outer exponent cancel out, and you're left with x^8 . Select choice (D).
5. D To solve this one, Plug In for d and e , but don't forget your restriction: $0 > d > e$. First, make $d = -2$ and $e = -8$; Quantity A is 16, and Quantity B is $\sqrt{16}$. Quantity A is greater, so eliminate answer choices (B) and (C). Next, make $d = -\frac{1}{8}$ and $e = -\frac{1}{2}$; now, Quantity A is $\frac{1}{16}$, and Quantity B is $\sqrt{\frac{1}{16}} = \frac{1}{4}$. Quantity B is now greater, so eliminate choice (A), and you're left with choice (D).
6. A Plug in $m = 2$ and $n = 4$, so $\frac{2 \times 4}{2^2} \sqrt{\frac{2^2}{4}} = \frac{8}{4} \sqrt{\frac{4}{4}} = 2\sqrt{1} = 2$, your target answer. When you plug in the values you chose for m and n for every answer, only choice (A) works.
7. C First, factor Quantity A into $4^7 \times 5^7$ to make it resemble Quantity B. Next, simplify the individual terms in Quantity B: $\left(\frac{4^{13}}{4^6}\right) = 4^7$, and $(5^4 \times 5^3) = 5^7$. The quantities are equal.
8. C Don't get caught up in tricks involving exponent rules—just calculate the quantities. In Quantity A, $0.8^2 = 0.64$, so $0.8^2 + 0.8^2 + 0.8^2 + 0.8^2$ equals 4×0.64 , or 2.56. In Quantity B, 1.6^2 also equals 2.56 (make sure you put the decimal in the right place), so the quantities are equal.
9. E You cannot have a square root in the denominator of a fraction. To rationalize (get rid of the root sign in) the denominator, multiply the numerator and denominator by $2 - \sqrt{3}$: $\frac{(2 - \sqrt{3})(2 - \sqrt{3})}{(2 + \sqrt{3})(2 - \sqrt{3})} = \frac{4 - 4\sqrt{3} + 3}{4 - 3} = \frac{7 - 4\sqrt{3}}{1}$. Choice (E) is correct.
10. D There are only 3 possible values for b : 0, 1, and 2. So just plug those values into Quantity A. Start with 0, because it's the easiest: Anything raised to the power of 0 is 1. Quantity B is greater, so eliminate choices (A) and (C). Next, try 1: $\left(1 + \frac{1}{2}\right) = \frac{3}{2}$. Quantity B is still greater, so no new answers can be eliminated. Finally, try 2: $\left(2^2 + \frac{1}{2}\right)^2 = \left(4 + \frac{1}{2}\right)^2 = \left(\frac{9}{2}\right)^2 = \frac{9^2}{2^2} = \frac{81}{4} = 20\frac{1}{4}$. The two quantities are equal, so eliminate choice (B) and select choice (D).
11. D Start by using the second equation to plug in values for b , and then use the first equation to find the corresponding value for a . In the equation: $b^2 = 16$, b could be 4, then a would be 3; Quantity B is greater, so eliminate choices (A) and (C). However, b could also be -4 , in which case a would be -3 ; Quantity A is now greater, so eliminate choice (B), and you're left with choice (D).

1. C If $(x + y)(x - y) = 0$ and $xy \neq 0$, then either $x + y = 0$ or $x - y = 0$; hence, $x = y$ or $x = -y$. Fortunately, the variables will be positive and will work out the same either way. Plug in values for x and y to simplify the comparison: Try making both x and y equal to 2. Now Quantity A is $6\sqrt{\frac{19}{2(2)^2}}$, or $6\sqrt{\frac{19}{2^3}}$; Quantity B is $\sqrt{\frac{342}{4}}$. At this point, manipulate Quantity B to make it look like Quantity A. Since Quantity A contains 19, test 19 as a factor of 342 in Quantity B: $\sqrt{\frac{342}{4}} = \sqrt{\frac{19 \times 9 \times 2}{2^2}}$; multiplying by $\frac{2}{2}$ under the radical yields $\sqrt{\frac{19 \times 9 \times 2 \times 2}{2^2 \times 2}}$, or $\sqrt{\frac{19 \times 36}{2^3}}$. Moving the perfect square 36 outside the radical yields $6\sqrt{\frac{19}{2^3}}$.
2. B The only thing to worry about here is not getting caught in the trap answer choice (D). Remember that you cannot take the roots before you add up what's under the root sign. If you add first, you'll find that you're looking for $\sqrt{150}$. 150 has factors of 25 and 6. You can take the square root of 25 (which is 5), but not of 6, so leave it under the root sign. Select choice (B).
3. D From the restriction in this problem, x could equal a positive fraction, 0, or any negative number. If you raise 1 to any power, it remains equal to 1. This also applies if x equals 0, because any number raised to the 0 power equals 1. Therefore, only possible correct answer is choice (D).
4. 24 Don't calculate that big number under the radical, since your on-screen calculator won't do cube roots anyway. Instead, remember that $\sqrt[3]{8 \times 27 \times 64} = \sqrt[3]{8} \times \sqrt[3]{27} \times \sqrt[3]{64} = 2 \times 3 \times 4$, so the answer is 24.
5. $\frac{3}{4}$ or any equivalent value, such as $\frac{6}{8}, \frac{9}{12}, \frac{12}{16}$ etc.

Remember that a negative exponent means "positive reciprocal," and thus $2^{-5} = \frac{1}{2^5}$. A fractional exponent asks you to find the root, so $4^{\frac{1}{2}} = \sqrt{4} = 2$. Therefore, the initial equation can be rewritten as $\frac{x}{12} = \frac{1}{2^5} \times 2$ or $\frac{x}{12} = \frac{1}{2^4}$. Simplifying again, $\frac{x}{12} = \frac{1}{16}$.

Multiply both sides by 12 to find that $x = \frac{12}{16} = \frac{3}{4}$, the final answer.

6. C If you're extremely comfortable working with exponents, start by converting everything to the same base so you can use the basic exponent rules: $\frac{8^r}{4^s} = \frac{(2^3)^r}{(2^2)^s} = \frac{2^{3r}}{2^{2s}} = 2^{3r-2s}$. Thus $2^{3r-2s} = 2^t$, and $3r - 2s = t$; solve for r , and $r = \frac{2s+t}{3}$. Alternately, you could dispense with all the algebra and Plug In numbers to make the equation true: If $r = 2$ and $s = 3$, for instance, $\frac{64}{64} = 2^t$, so $t = 0$. Plug your values for s and t into the answers, and only choice (C) hits your target answer of 2.
7. $\frac{1}{2}$ When working with exponents, everything must have the same base. Express 9 as 3^2 . Now the given expression is $(3^2)^3 = 3^{2y+5}$. When raising a power to another power, you multiply the exponents. This gives you $3^6 = 3^{2y+5}$. The bases are the same, so now you can set the exponents equal to each other and solve for y : $6 = 2y + 5$. The correct answer is $\frac{1}{2}$.
8. 8 Rewrite 72^4 in terms of prime factors. $72^4 = (9 \times 8)^4 = (3^2 \times 2^3)^4$. You can now distribute the 4 to get $3^8 \times 2^{12}$. Now break down the right side of the equation. $16 = 2^4$, so you can rewrite the right side as $2^4 \times 6^n$ or $2^4 \times (2 \times 3)^n$. The whole equation is therefore $3^8 \times 2^{12} = 2^4 \times 2^n \times 3^n$. That means that $3^8 = 3^n$ and $2^{12} = 2^4 \times 2^n$, so n must equal 8.
9. C This problem is simplified when you recognize that this is actually a common quadratic equation of the formula $x^2 - y^2 = x^2 - 2xy + y^2$. Therefore $(\sqrt{245} - \sqrt{75})^2 = 245 - 2(\sqrt{245})(\sqrt{75}) + 75$ simplifies to $320 - 2(\sqrt{245})(\sqrt{75})$. Rather than multiplying $(\sqrt{245})(\sqrt{75})$ out, check to see if these large numbers simplify to the multiples of perfect squares. As is usually the case on the GRE, they do. $\sqrt{245} = \sqrt{5 \times 49} = 7\sqrt{5}$ and $\sqrt{75} = \sqrt{3 \times 25} = 5\sqrt{3}$, so $2(\sqrt{245})(\sqrt{75}) = 2(7\sqrt{5})(5\sqrt{3}) = 70(\sqrt{15})$. Therefore,

10. C and D

Try plugging in each of the answers rather than solving the quadratic:

$$x = -\sqrt{2} \quad (-\sqrt{2})^2 - (-\sqrt{2})\sqrt{2} + 3(-\sqrt{2})\sqrt{3} = 2 + 2 - 3\sqrt{6} \neq \sqrt{54}$$

$$x = -3\sqrt{2} \quad (-3\sqrt{2})^2 - (-3\sqrt{2})\sqrt{2} + 3(-3\sqrt{2})\sqrt{3} = 9 \times 2 + 3 \times 2 - 9\sqrt{6} = 24 - 9\sqrt{6} \neq \sqrt{54}$$

$$x = -3\sqrt{3} \quad (-3\sqrt{3})^2 - (-3\sqrt{3})\sqrt{2} + 3(-3\sqrt{3})\sqrt{3} = 9 \times 3 + 3\sqrt{6} - 9 \times 3 = \sqrt{54}$$

$$x = \sqrt{2} \quad (\sqrt{2})^2 - (\sqrt{2})\sqrt{2} + 3(\sqrt{2})\sqrt{3} = 2 - 2 + 3\sqrt{6} = \sqrt{54}$$

11. 3 Here's how to simplify this equation using laws of exponents:

$$3 \sqrt[3]{\frac{x^{\frac{3}{4}}}{x^{-\frac{13}{4}}}} = (x^{\frac{1}{4}} \cdot x^{\frac{5}{4}})^2$$

$$3x \sqrt[3]{x^{\left(\frac{3}{4} - \left(-\frac{13}{4}\right)\right)}} = \left(x^{\frac{3}{2}}\right)^2$$

$$3 \sqrt[3]{x^{\frac{16}{4}}} = x^3$$

$$3 \sqrt{x^4} = x^3$$

$$3x^2 = x^3$$

$$3 = \frac{x^3}{x^2}$$

$$3 = x$$

1. D Plug in for y . If $y = 2$, then in Quantity A you have $-\frac{2^3}{2} = -4$, and in Quantity B you have $\frac{2^2}{2} = 2$. In this case, Quantity B is bigger than Quantity A, so you can eliminate choices (A) and (C). Plug in again using $y = -2$: in Quantity A you have $-\frac{(-2)^3}{2} = 4$, and in Quantity B you have $\frac{(-2)^2}{2} = 2$. In this case, Quantity A is bigger, so you can eliminate choice (B). The correct answer is therefore choice (D).
2. C First solve for the cube roots of 64 and 8. $\sqrt[3]{64} = 4$, and $\sqrt[3]{8} = 2$. Next, calculate the value inside the parentheses. You can now rewrite the equation as $(4 + 2)^2 = (6)^2 = 36$. The correct answer is choice (C).
3. A, C, and D
Based on the answer choices, it looks like you're being asked to find the prime factors of 17,640 and then re-write them in a few different ways. Instead of starting there, though, take a look at the number you're being asked to factor. Clearly, it's a multiple of 10. And if it's a multiple of 10, then, whatever else might factor in, a 5 and a 2 have to show up somewhere. Eliminate choices (B) and (E), neither of which contains a 5. From there, look for an opportunity to use your on-screen calculator easily: Choice (D) shouldn't be too hard to multiply (as there are no exponents) and works out to 17,640. Expand out the 8 ($2 \times 2 \times 2$) and the 9 (3×3) of choice (D) to compare to choice (A). They are equivalent. Finally, you may either use the on-screen calculator to check choice (C), or simply compare to choice (A) (they've combined a 2 and a 5, and compressed the remaining numbers since they all have the same power). In either case, you should get that it also works out to 17,640.
4. 61 Raise both sides of the equation to the third power, and you'll have $x + 3 = 64$, so $x = 61$.
5. C As soon as you see variables in the answer choices, set up your scratch paper to Plug In. Start with the number under the radical: If $q = 4$, then $\frac{1}{p} = 2$, and p , which is also your target answer, is $\frac{1}{2}$. Plug 4 into the answers for q , and only choice (C) is $\frac{1}{2}$.
6. D and F As soon as you see variables in the answer choices, set up your scratch paper to Plug In. Start with an easy number like $j = 2$; choices (A) and (B) are fractions and choice (C) is 1, so eliminate all three. Next, try a number like $j = -2$; now choice (E) is -8 , so eliminate it. Try more numbers if time permits; choices (D) and (F) will always work.
7. 6006 You can try to hammer this out on your calculator, but it's a lot easier to use the common quadratic $(x - y)(x + y) = x^2 - y^2$. Start with the first 2 terms: $(\sqrt{79} - 1)(\sqrt{79} + 1) = (\sqrt{79})^2 - 1^2$, or $79 - 1 = 78$. For the last 2 terms, $(\sqrt{78} - 1)(\sqrt{78} + 1) = (\sqrt{78})^2 - 1^2$, or $78 - 1 = 77$. The whole expression, then, equals $78 \times 77 = 6006$. If you don't recognize the common quadratic, you can get the same product by FOILING the first 2 terms and the last 2 terms separately and multiplying the results.
8. C Use Plugging In to solve the problem. The swimming pool has a total volume of $(x + y)$. You're trying to find the depth, or one side of the cube. Choose easy numbers. It helps to start with the depth, which is your target. If the depth is 2, then the total volume has to be 2^3 , or 8. You could choose $x = 7$ and $y = 1$, but really you only use $x + y$ in the answers, so all you need is $x + y = 8$. Now Plug In to find your target in the choices. Choice (A) = 8, which doesn't match. Choice (B) is a fraction, which doesn't match. Choice (C) is $\sqrt[3]{8}$ which does equal 2, so keep it. Choice (D) is 8^3 , which doesn't match. Choice (E) is $\frac{2}{3}$ which doesn't match.
9. 234 Rewrite the numerator in terms of powers of 3. $81 = 3^4$, so $81^3 = (3^4)^3$, or 3^{12} . $27 = 3^3$, so $27^3 = (3^3)^3$, or 3^9 . Therefore, you can rewrite the entire numerator as $\frac{3^{12} - 3^9}{3^7}$. Now you can factor the numerator so that you get $\frac{3^9(3^3 - 1)}{3^7} = 3^2(26) = 234$.

10. A, C, and G

This algebra question has numbers for answer choices, so set up your scratch paper to Plug In the Answers and look for an integer

answer. If $x = 2$, then $\frac{4^2}{2^4} = \frac{16}{16} = 1$, so choice (A) works. If $x = 3$, then $\frac{4^3}{3^4} = \frac{64}{81}$, so eliminate choice (B). If $x = 4$, then $\frac{4^4}{4^4} = 1$, so

choice (C) works. If $x = 5$, then $\frac{4^5}{5^4}$ isn't an integer, since you cannot cancel all the 5's in the denominator; eliminate choice (D). You

could calculate it, but it's easier to think in terms of reducing the fraction. Likewise in choice (E), $\frac{4^6}{6^4}$ isn't an integer, because each of the 6's in the denominator has a 2 you can cancel, but a 3 you cannot cancel. Eliminate choice (E) as well as (F), since it too is not an integer. Finally, $\frac{4^8}{8^4}$ is an integer: Expand it out to $\frac{4 \times 4 \times 4 \times 4 \times 4 \times 4 \times 4 \times 4}{8 \times 8 \times 8 \times 8} = \frac{4 \times 4 \times 4 \times 4 \times 4 \times 4 \times 4 \times 4}{4 \times 2 \times 4 \times 2 \times 4 \times 2 \times 4 \times 2}$ which cancels down to all 1's and 2's. Choices (A), (C), and (G) are correct.



Lines and Angles

LINES AND ANGLES

This is geometry 101. Before you get to shapes, such as circles and triangles, you must first have a solid grasp of lines, intersecting lines, parallel lines, and degree measurements.

There are a couple of key concepts you need to know.

- There are 180 degrees in a straight line.
- A perpendicular line forms a right angle.
- When two lines intersect, four angles are formed.
- Opposite angles are equal.

PARALLEL LINES

Line and angle questions will often involve parallel lines. Never assume two lines are parallel, no matter what they show you, unless you are told they are parallel or you can prove it.

When two parallel lines are intersected by a third line, two kinds of angles are formed, big ones and small ones. All big angles are equal, all small angles are equal, and any big angle plus any small angle will add up to 180 degrees.

On all geometry problems, use your scratch paper and follow these five steps.



Step 1: Draw your shape

In some cases the test will give you a shape, which you may or may not be able to trust, or it will give you a word problem and leave it up to you to envision the shape. As with every other part of the test, getting your hand moving is an important first step to entering the problem. Get your shape down on your scratch paper so that you can begin working with it there. On Quant Comp questions involving geometry, instead of plugging in more than once, you may have to draw your shape more than once.

Step 2

Step 2: Fill in what you know

Whether you are given the shape or not, you will be given a certain amount of information regarding the shape, such as the measure of some angles, lengths of some sides, area of some sides, or volume. Fill in what you know.

Step 3

Step 3: Make deductions

If you are given two angles of a triangle, find the third. If you are given the radius of a circle, find the area. Often this will be the entire problem. Geometry on the GRE is all about finding the missing piece of information. You will be given just enough information to find the piece that is missing.

Step 4

Step 4: Write down relevant formulas

If step three didn't get you the answer, you must still be missing a piece of information. Writing down the formula is a way to organize your information and to tell you what is missing. When you write your formulas down, fill in the information you have directly underneath the relevant part of the formula. It seems simple, but this way you can't make a mistake, and finding the missing piece of information becomes a simple case of solving for x .

Step 5

Step 5: Drop heights/draw lines

If you're still stuck, you may need to manipulate or subdivide your shapes. If you have triangles, draw in the height. Have you created a 30-60-90? A 45-45-90? Or a Pythagorean triple? Try subdividing the shape or, if it's a three-dimensional figure, dashing in the hidden lines.

For more practice and a more in-depth look at The Princeton Review math techniques, check out our student-friendly guidebook, *Cracking the New GRE*.

DRILL 1
Question 1

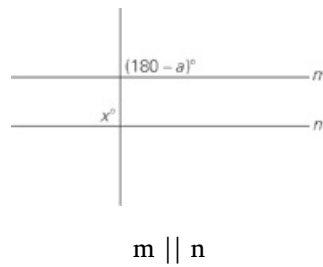

Quantity A

a

Quantity B

90

- Quantity A is greater.
- Quantity B is greater.
- The two quantities are equal.
- The relationship cannot be determined from the information given.

Question 2

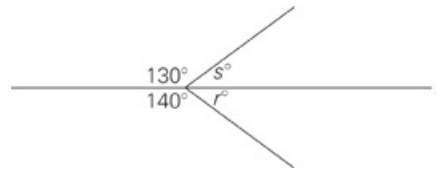

Quantity A

r

Quantity B

s

- Quantity A is greater.
- Quantity B is greater.
- The two quantities are equal.
- The relationship cannot be determined from the information given.

Question 3

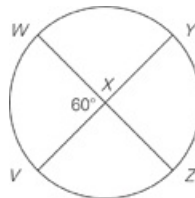

If X is the center of the circle above, then what is the sum of the measures of $\angle WXY$ and $\angle VXZ$?

- 60°
- 120°
- 220°
- 240°

Question 4

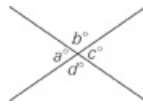

In the figure above, c is $\frac{4}{5}$ of d . What is the value of c ?

- 72
- 80
- 100
- 108
- 120

Question 5

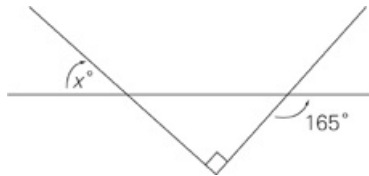

What is the value of x ?

- 15
- 55
- 65
- 75
- 115

Question 6

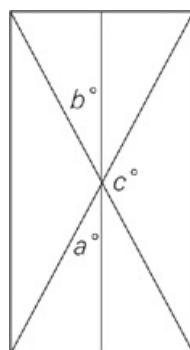

Quantity A

$a + b$

Quantity B

$180 - c$

- Quantity A is greater.
- Quantity B is greater.
- The two quantities are equal.

- The relationship cannot be determined from the information given.

Question 7

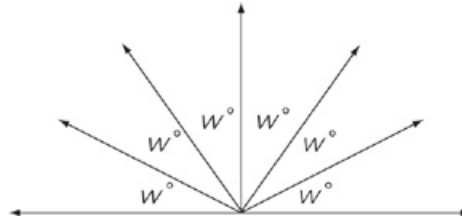

In the figure above, what is the value of w ?

- 10°
- 15°
- 30°
- 45°
- 60°

Question 8

What is the area of a regular hexagon with side length 8?

- 64
- $64\sqrt{3}$
- 78
- $78\sqrt{3}$
- $96\sqrt{3}$

Question 9

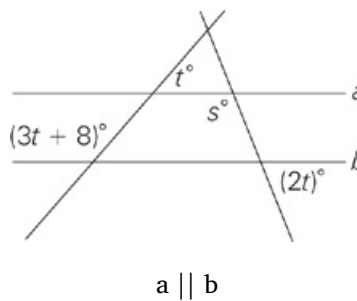

Quantity A

95

Quantity B

s

- Quantity A is greater.
- Quantity B is greater.
- The two quantities are equal.
- The relationship cannot be determined from the information given.

Question 10

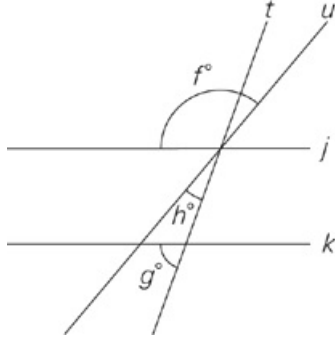

In the figure above, line j is parallel to line k . If $f = 130$ and $g = 70$, then $h =$

- 10
- 20
- 30
- 60
- 80

Question 11

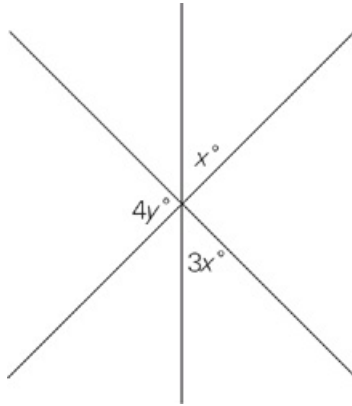

What is the value of y in the figure above, if $5x = 4y$?

- 25
- 50
- 60
- 80
- 100

Question 12

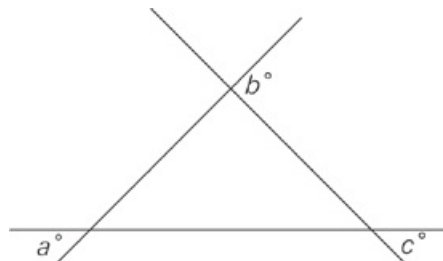

Quantity A

$$a + c$$

Quantity B

$$b$$

- Quantity A is greater.
- Quantity B is greater.
- The two quantities are equal.
- The relationship cannot be determined from the information given.

Question 13

A regular polygon with n sides has interior angles that measure p degrees each. The value of p when $n = 8$ is how much greater than the value of p when $n = 6$?

Question 14

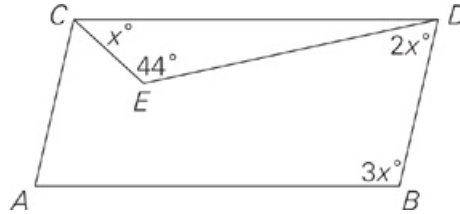

In the figure above, if AB is parallel to CD , then $\angle ABD =$

- 11°
- 22°
- 33°
- 46°
- 134°

DRILL 2
Question 1

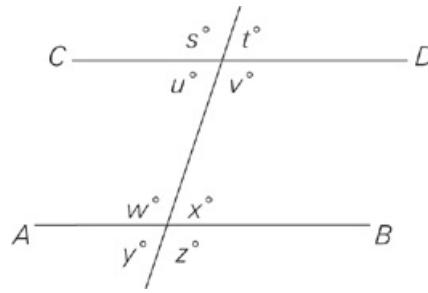

In the figure above, AB is parallel to CD. Which of the following must be equal to s ? Indicate all possible values.

- t
- u
- v
- w
- x
- y
- z

Question 2

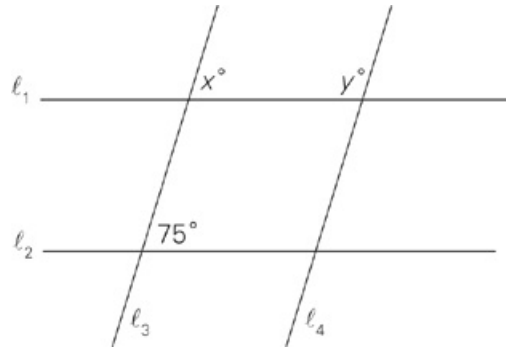

In the figure above, $l_1 \parallel l_2$ and $l_3 \parallel l_4$. What is the value of $x + y$?

Question 3

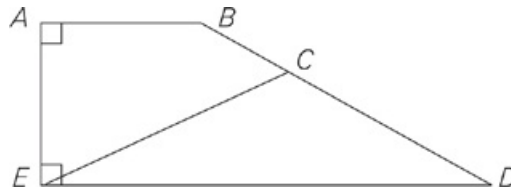

If $\angle ABC = 150^\circ$ and $\triangle CED$ is isosceles, what is the value of $\angle CED$, in degrees?

Question 4

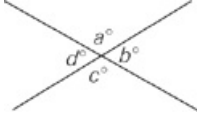

If $30 < a < 64$, which of the following could be the value of $b + d$?
Indicate all possible values.

- 32
- 108
- 147
- 232
- 247
- 289
- 328

Question 5

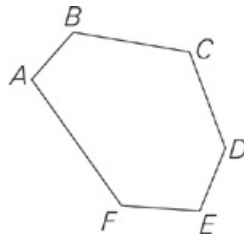

In the hexagon above, $\angle A = 101^\circ$, $\angle E = 111^\circ$, and all other angles are equal. What is the measure of $\angle F$?

- 82°
- 106°
- 120°
- 127°
- 222°

Question 6

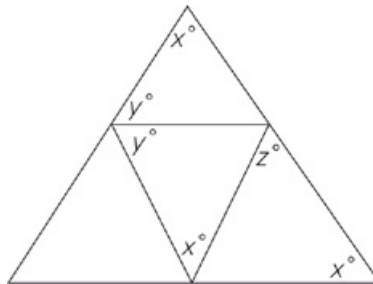

In the figure above, what is the sum of x and y in terms of z ?

- $z + 90$
- $\frac{z}{2} + 90$
- $180 - 2z$

Question 7

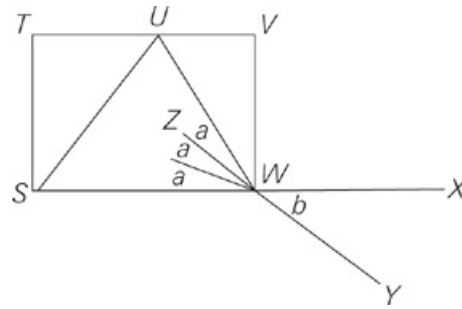

Note: Figure not drawn to scale.

In the figure above, STVW is a square, SX and YZ intersect at point W, and UW is twice as long as UV. What is the value of b?

- 20
- 40
- 60
- 120
- 180

Question 8

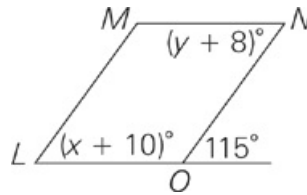

If LMNO is a parallelogram, what is the value of $x + y$?

- 75
- 92
- 110
- 128
- 150

Question 9

A and B are the endpoints of a line segment. Segment AB is crossed through point C by another line segment with endpoints D and E. If $\angle ACD > 90^\circ$, and the sum of $\angle ACE$ and $\angle BCD$ is x° , then which of the following must be true?

- $x < 90$
- $x > 90$
- $90 < x < 180$
- $x < 180$
- $x > 180$

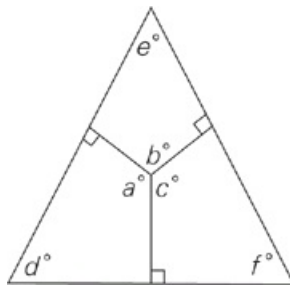

In the figure above $a + b + f =$

- $180 + (c + d + e)$
- $360 - (c + d + e)$
- $360 + (c + d - e)$
- $540 - (c + d + e)$
- $540 - (c + d - e)$

Question 11

If a regular polygon has x angles each measuring q degrees, then what is the value of q ?

- $\frac{180(x - 3)}{x}$
- $180(x - 3) + 180$
- $\frac{30x + 180}{x}$
- $\frac{180(x - 2)}{x}$
- $\frac{360}{x} - 10x$

Question 12

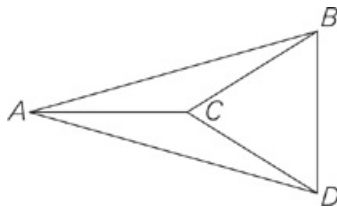

Triangles ABC, ACD, and ABD are all isosceles triangles. Point E (not shown) is the midpoint between points B and D. If the ratio of

$\frac{BC}{CE} = \frac{\sqrt{3}}{1}$, then what is the measure, in degrees, of $\angle CAD$?

- 10
- 15
- 30
- 45
- Cannot be determined from the information given

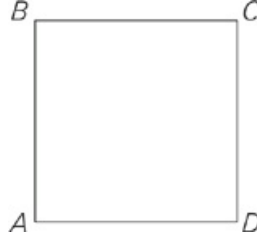

ABCD is a square. Points E and F, not shown, are the midpoints of \overline{BC} and \overline{CD} respectively. Line segments are drawn to connect points E and F to A. Which of the following must be true?

Indicate all possible values.

- $\angle CEF = 45^\circ$
- $\angle FEA > 45^\circ$
- $\angle EFA < 90^\circ$
- $\angle FAD = 30^\circ$
- $\angle AEB = 60^\circ$
- $\angle AFD = 45^\circ$

ANSWERS

Drill 1

1. D
2. B
3. D
4. B
5. D
6. C
7. C
8. E
9. A
10. B
11. A
12. C
13. 15
14. C

Drill 2

1. C, D, G
2. 180
3. 30
4. E, F
5. D
6. B
7. B
8. B
9. D
10. D
11. D
12. B
13. A, B, C

Drill 1

1. D Two parallel lines—with a line cutting through them—create big angles (bigger than 90°) and small angles (smaller than 90°). Any big angle plus any small angle equals 180° . In the figure, x appears to be a big angle and $(180 - a)$ appears to be a small angle. So $x + (180^\circ - a) = 180^\circ$, or $x = a$. But in fact, because you can't trust the figure, you don't know whether x (and therefore a) is really a big, small, or 90° angle. The answer is choice (D).
2. B Use the Rule of 180 to find $r = 40$ and $s = 50$.
3. D Because $\angle WXY$ forms a line with a 60° angle, it must be $180^\circ - 60^\circ = 120^\circ$; $\angle WXY$ and $\angle VXZ$ are vertical angles, so $\angle VXZ$ must be 120° as well. The sum of the measures of $\angle WXY$ and $\angle VXZ$ is $120^\circ + 120^\circ = 240^\circ$.
4. B The sum of c and d is 180, so you know that $\frac{4}{5}d + d = 180$. Solve this equation: $d = 100$. If $d = 100$, then $c = 80$. The answer is choice (B).
5. D Remember that a straight line measures 180° . Therefore, the angle inside the triangle next to the 165° angle measures $180^\circ - 165^\circ = 15^\circ$. A triangle contains 180° and a right angle measures 90° . The third angle in that triangle must measure $180^\circ - (90^\circ + 15^\circ) = 75^\circ$. Vertical angles are equal, so $x = 75$. The answer is choice (D).
6. C Plug in your own numbers, choosing easy values for the angle measures. If $a = 40$, and $b = 60$, then the angle in between them must measure 80° to complete the 180° in a straight line. That angle and the angle measuring c° are vertical, so $c = 80$ as well. Both quantities then equal 100; eliminate choices (A) and (B). Try a new pair of numbers for b and c , and you will realize that plugging in any values yields the same result, making choice (C) the answer.
7. C There are 180° in a straight line. The straight line is divided into six equal angles in this figure, so $180^\circ \div 6 = 30^\circ$.
8. E A hexagon has 6 sides. The total number of degrees in the interior of a polygon of n sides is given by $(n - 2)180 = (6 - 2)180 = 720$.
A regular polygon is one in which the sides and angles are all equal. Dividing 720° by 6 gives you 120° for each interior angle in the hexagon. Now draw the hexagon and a point in its center. Connecting the center to each vertex divides the hexagon into six equal triangles. These segments from the center to each vertex are all of equal length, so the triangles are isosceles. These segments also bisect each of the interior angles, so the base angles of these triangles each measure 60° . Thus, the remaining angle in each triangle (near the center of the hexagon) also measures 60° , and therefore these triangles are equilateral, with sides of length 8. The area of an equilateral triangle of side x is $\frac{x^2\sqrt{3}}{4} = \frac{8^2\sqrt{3}}{4} = 16\sqrt{3}$. Multiplying the area of each triangle by 6 gives you $96\sqrt{3}$; the answer is choice (E).
9. A First, solve for t : Lines a and b are parallel, so $(3t + 8) + t = 180$; $4t + 8 = 180$; $4t = 172$; $t = 43$. Lines a and b are parallel and you know that $2t + s = 180$, so $2(43) + s = 180$; $86 + s = 180$; $s = 94$. Quantity A is greater.
10. B If $f = 130$, then both large angles formed by lines t and k also measure 130° . The small angles formed by those two lines therefore measure 50° (notice that one of these angles is the left base angle of the triangle). If $g = 70$, then the angle above it (the other base angle of the triangle) must measure 110° to complete the 180° in a straight line. So far, you have 160° in the triangle. To complete the 180° total in the triangle, h must measure 20° . The answer is choice (B).
11. A The angle between the ones marked x° and $3x^\circ$ is vertical to the one that measures $4y^\circ$. These three angles form a straight line, so $x + 4y + 3x = 180$. Since $4y = 5x$, $x + 5x + 3x = 180$; $9x = 180$; $x = 20$. Therefore $4y = 5x = 100$; $y = 25$.
12. C Plug in values for the unknown angles. When $a = 60$ and $b = 130$, the angle vertical to a also measures 60° , and the angle adjacent to b within the triangle must measure $180^\circ - 130^\circ = 50^\circ$. The sum of the angles in a triangle is 180° . Therefore, the remaining angle measures $180^\circ - 60^\circ - 50^\circ = 70^\circ$. Angle c is vertical to the 70° angle, so $c = 70$. Quantity A is $60 + 70 = 130$ and Quantity B is 130; the quantities are equal. Eliminate choices (A) and (B). Plugging in a second set of numbers will show you that any set of numbers yields the same result, so the answer is choice (C). Alternatively, you could use algebra to determine that the three angles in the triangle measure a° , $(180 - b)^\circ$, and c° . Therefore, $a + (180 - b) + c = 180$. Subtract 180 from each side of this equation and add b to each side; $a + c = b$. The quantities are equal.
13. 15 The formula for the total interior angles of a polygon with n sides is $(n - 2)180$, so the interior angles of an 8-sided polygon total $6 \times 180 = 1080^\circ$. Since it's a regular polygon, divide that total by the 8 angles to determine that $p = 135$ when $n = 8$. For the 6-sided polygon, the total of the interior angles is $4 \times 180 = 720^\circ$, and each angle is $720 \div 6 = 120$. Thus $p = 120$ when $n = 6$, and $135 - 120 = 15$.

14. C Use the laws of parallel lines to fill in the diagram. $\angle ABD + \angle BDE + \angle CDE = 180^\circ$ because lines AB and CD are parallel. $\angle CDE = 180^\circ - x^\circ - 44^\circ$. Therefore, $3x + 2x + 180 - x - 44 = 180$. Solving for x gives you 11, and $\angle ABD = 33^\circ$.

- C, D, and G
Remember that when a line intersects two parallel lines, it makes large and small angles; all of the large angles are equal, as are all of the small ones. In this case, s is equal to the other large angle measures: v , w , and z . Choices (C), (D), and (G) work.
- 180 You don't actually have to do any math for this question. When parallel lines intersect, any big angle plus any little angle is 180° ; since x is a little angle and y is a big angle, the sum must be 180. However, you could also use the rules regarding opposite and corresponding angles, or the parallelogram rules, with the 75° in the corner. In this case, $x = 75$ and $y = 105$, so $75 + 105 = 180$.
- 30 If you draw a line down from B to the base of the figure, you can subtract the 90° that are left over from the 150° angle and you'll have 60° left. This makes a 30-60-90 triangle with vertex D. And if $\triangle CED$ is isosceles, that makes angle CED 30° as well.
- E and F Because they are supplementary angles, $a + b = 180$. So subtract the range of values for a from 180 to get $116 < b < 150$. You know that b and d are equal, so double b to get $232 < b + d < 300$. Only choices (E) and (F) fall within this range. (You could also Plug In the Answers on this question.)
- D The total number of degrees in a hexagon is 720; if you don't know the formula, $(s - 2) \times 180$, you can divide the hexagon into 4 non-overlapping triangles. Subtract the two known angles, leaving you with 508° for the four remaining angles. Since the remaining angles are equal, each angle is $508 \div 4 = 127^\circ$.
- B It's a geometry problem with variables in the answer choices, so draw the figure and set up your scratch paper to Plug In. Try $x = 60$ and $y = 70$; the missing angle in the small triangle on top is now 50° , as is the missing angle in the small triangle in the middle. Since z combines with the 2 angles you just found to form a line, $2(50) + z = 180$, and $z = 80$. The problem asked for the sum of x and y , so plug 80 in for z to all the answers and look for your target answer of 130. Only choice (B) works.
- B The question is asking for a specific amount and there are no variables in the answer choices, so PITA. Starting with choice (C), $b = 60$. By vertical angles, $b = 2a$, so $a = 30$. If $a = 30$, then $\angle SWU = 90$. This won't work because all four angles of a square equal 90° and $\angle SWU$ must be smaller than 90 . Eliminate choices (C), (D), and (E). Try a smaller value, such as in choice (B). Now $b = 40$ which means $a = 20$, $\angle SWU = 60$ and $\angle UWV$ is 30° . A right triangle in which the hypotenuse is twice one of the sides is a 30:60:90 triangle. That means that triangle UWV is a 30:60:90 triangle in which $\angle VUW$ is 60° and $\angle UWV$ is 30° . Per our calculations, that's what $\angle UWV$ is supposed to be, so the correct answer is choice (B).
- B Fill in the diagram little by little. Angle LON must be equal to 75 degrees, because $\angle LON + 115^\circ = 180^\circ$ to make a straight line. The shape is a parallelogram, so it must also be true that $\angle LON = \angle LMN$. There are 360 degrees in the whole parallelogram, and $\angle LON + \angle LMN = 150$, so there are $360 - 150 = 110$ degrees remaining in the parallelogram. Thus, $(x + 10) + (y + 8) = 110$. You can now simplify the expression to get $x + y = 92$.
- D For this problem it helps to draw the figure. When you do, exaggerate the angles as shown in the diagram below. From the diagram, $\angle ACE$ and $\angle BCD$ are both smaller than 90° . The sum of any two angles less than 90° will be less than 180° ; this sum is x from the question, making choice (D) correct. You can also plug in your own numbers to the diagram to test the choices. If $\angle ACD$ is 120° , then $\angle ACD$ and $\angle BCD$ are both 60° and add up to 120° , which is now the value of x . You can eliminate choices (A) and (E). To eliminate further, try a really big number such as 170° for $\angle ACD$. Angles $\angle ACE$ and $\angle BCD$ are now both 10° and add up to 20° , the new value of x . You can eliminate choices (B) and (C), leaving choice (D) as the correct answer.
- D As soon as you see variables in the answer choices, draw your figure and set up your scratch paper to Plug In. The sum of d , e , and f has to be 180, so try $d = 50$, $e = 60$, and $f = 70$. Similarly, the sum of a , b , and c has to be 360, so try $a = 110$, $b = 120$, and $c = 130$. Since the problem asked for $a + b + f$, your target answer is $110 + 120 + 70 = 300$. Now plug your values for c , d , and e into the answer choices; only choice (D) hits your target.
- D To solve this question, plug in some easy values for the variables. For example, if the polygon were a square, then $x = 4$. Since each angle would equal 90, $q = 90$, your target answer. Check all the answers by plugging in $x = 4$. Only $\frac{180(4-2)}{4} = 90$, so choice (D) is correct.
- B To answer this question, Plug In the Answers. Because $\frac{\overline{BC}}{\overline{CE}} = \frac{\sqrt{3}}{1}$, triangle BCE is a 30:60:90 triangle and BCD is an equilateral triangle with all angle measures equal to 60. Start with choice (C). If $\angle CAD = 30$, then since triangle ACD is isosceles, $\angle CAB = 30$ as well. Since both triangles ABC and ACD share \overline{AC} , and triangle ABC is isosceles, then $\angle CAB$ and $\angle CBA$ are both equal to 30 as well. The angles within triangle ABD should add up to 180. However, $\angle CAD + \angle CAB + \angle CDA + \angle CDB + \angle CBD + \angle CBA = 30 + 30 + 30 + 60 + 60 + 30 = 240$, which is too big; eliminate choices (C) and (D), which is bigger. Now try choice (B). If $\angle CAD = 15$, then $\angle CDA = 15$ as well, and $\angle CAB$ and $\angle CBA$ are both equal to 15 as well. Verify that the angles will add up to 180 for

correct answer.

13. A, B, and C

To solve this question, draw and label the figure. When drawn and labeled, the figure should look like this:

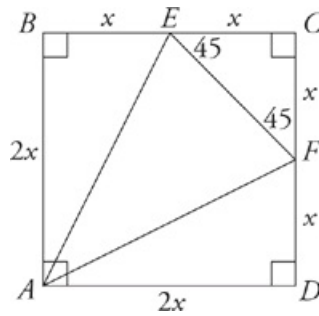

Since points E and F are midpoints of the sides of a square and $\angle C$ is a right angle, triangle ECF is a 45:45:90 triangle; thus choice (A) must be correct. Since $\angle CEF = 45^\circ$, if $\angle FEA$ also equaled 45, then $\angle CEA$ would be a right angle and would be perpendicular to \overline{BC} ; instead, since $\angle FEA + 45 > 90$, then $\angle FEA > 90$ and choice (B) must be correct. If $\angle EFA = 90$, then $\angle FEA = 90$, and thus $\angle EAF = 0$; since $\angle EAF > 0$, $\angle EFA < 90$, so choice (C) must be correct. If $\angle FAD = 30$, then triangle FAD would be a 30:60:90 right triangle with legs of x and $x\sqrt{3}$ and a hypotenuse of $2x$; since that is not the case, $\angle FAD \neq 30$; eliminate choice (D). If $\angle AEB = 60$, then triangle EAB would be a 30:60:90 right triangle with legs of x and $x\sqrt{3}$ and a hypotenuse of $2x$; since that is not the case, $\angle AEB \neq 60$; eliminate choice (E). If $\angle AFD = 45$, then $\angle FAD = \angle EAB = 45$, which would mean that $\angle EAF = 0$; since $\angle EAF > 0$, $\angle AFD$ cannot = 45; eliminate choice (F).



Triangles

TRIANGLES

Triangles on the GRE are suspicious. They are suspicious because of their tendency to fall into one of two categories: special right triangles and Pythagorean triples. Luckily, this also makes them suspiciously easy.

Triangles have sides, angles, and heights. The angles of any triangle will always add up to 180° . This means that if you have two angles, you can always figure out the third. If two angles of a triangle are equal (isosceles triangles) then the sides opposite those angles will also be equal. The same is true of the reverse; if the sides are equal, then the angles will be too. The height of a triangle is the line (not necessarily shown) from any point perpendicular to the side opposite that point. The height of a triangle is not necessarily drawn on a figure. Here are some examples.

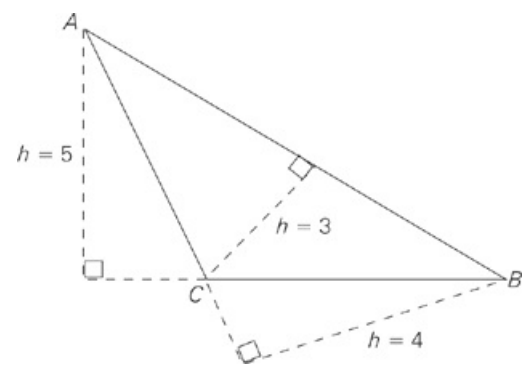

Note: The height is the dashed line.

In this case, if you use side CB as your base, your height will be five. If you use side AC as your base, your height will be four. You can use any side of a triangle as a base.

RIGHT TRIANGLES

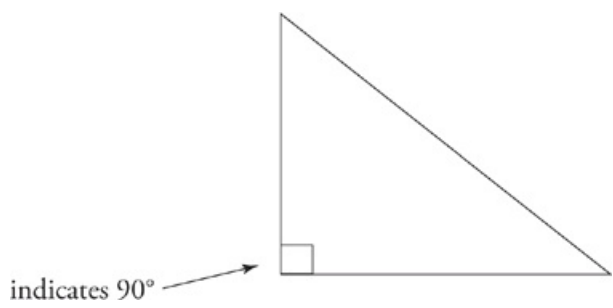

A right triangle means that one of the angles in a triangle is 90° . This will be noted on the figure. Never assume an angle is 90° unless you're told it is or you can prove it. The side opposite the 90° angle is called the hypotenuse. On right triangles you can apply the Pythagorean theorem, which states that $a^2 + b^2 = c^2$ where c^2 is the hypotenuse. This means that the sum of the squares of the two shorter sides will always be equal to the square of the longest side. If you are given the length of any two sides of a right triangle, you can always find the third. Don't forget to Ballpark and eliminate before you spend time figuring out the square root of one of the sides.

SPECIAL RIGHT TRIANGLES

Remember that the GRE is not a test of your ability to be a calculator. Rarely will you have to actually apply the Pythagorean theorem to find the third side of a triangle. More often, right triangles will turn out to be one of three common types called special right triangles. Because of this, be suspicious. When you see that a triangle has a right angle, start looking for clues that it is a special right triangle. Once you see it, the problem will go much faster.

30-60-90 Triangles

Take an equilateral triangle and fold it in half. The angle at the top has been bisected (cut in half). What was a 60° angle is now a 30° angle. The angles on the sides have not been touched; they are still 60° . The base of your triangle will be cut in half, and the angles where your fold hits the base will be 90° .

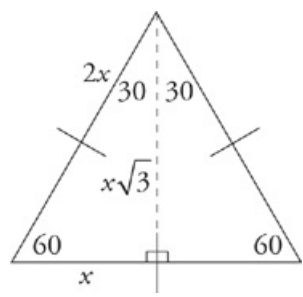

equilateral triangle in half—is x , then the longest side—the untouched one—will be $2x$. The middle side—the height of your equilateral triangle—is $x\sqrt{3}$. It's easy to get lost on a 30-60-90 triangle. Just remember that the longest side, $2x$, is opposite the 90° angle. If you see a right triangle pop up on a question and you see a $\sqrt{3}$ in the answer choices, look for this triangle. It is because of this triangle that you always know the area of an equilateral triangle because you always know the height.

Isosceles Right Triangles

When you cut a square in half on the diagonal, you create an isosceles right triangle. The untouched angles—one corner of the square—remains 90° . The other two angles have been bisected by the hypotenuse and are opposite the equal sides of the square. These angles are both 45° . If the two equal sides of this triangle have a side length of x , then the long side, the diagonal of the square, has a side length of $x\sqrt{2}$. This means that you always know the length of the diagonal of a square. Like the 30-60-90 triangle, if you know the length of one side, you know the length of the other two.

Remember that $\sqrt{2}$ is 1.4 (or Valentine's Day, 2/14) and $\sqrt{3}$ is 1.7 (St. Patrick's Day, 3/17). $\sqrt{2}$ is less than one and a half and $\sqrt{3}$ is less than two. This will help enormously with Ballparking. Also, so that you don't get confused, a 30-60-90 triangle has three different sides and three different angles, and the length of the middle side is $\sqrt{3}$. A right isosceles triangle has only two different side lengths and two different angles; the length of the longest side is the length of one of the equal sides times $\sqrt{2}$.

Pythagorean Triples

Some right triangles have whole numbers for all three sides. These are called Pythagorean triples. On a 3-4-5 triangle, for example, three squared is nine and four squared is 16, so they add to 25. If you double this triangle, you get a 6-8-10. The other most common Pythagorean triple is a 5-12-13.

When you see a right triangle, be suspicious

If you see a $\sqrt{3}$ or $\sqrt{2}$ anywhere in the problem, you know what you're looking for. If you see any of the numbers above (3, 4, 5, 6, 8, 10, 12, or 13), be very suspicious. If you see them paired with any of the other numbers, you most likely have your answer. Spotting a Pythagorean triple will save you lots of time—you won't have to do any calculating.

Step 1

Step 1: Draw your shape

In some cases the test will give you a shape, which you may or may not be able to trust, or it will give you a word problem and leave it up to you to envision the shape. As with every other part of the test, getting your hand moving is an important first step to solving the problem. Get your shape down on your scratch paper so that you can begin working with it there. On Quant Comp questions involving geometry, instead of Plugging In more than once, you may have to draw your shape more than once.

Step 2

Step 2: Fill in what you know

Whether you are given the shape or not, you will be given a certain amount of information regarding your shape such as the measure of some angles, lengths of some sides, area of some sides, or volume. Fill in what you know.

Step 3

Step 3: Make deductions

If you are given two angles of a triangle, find the third. You are given the radius of a circle, find the area. Often this will be the entire problem. Geometry on the GRE is all about finding the missing piece of information. You will be given just enough information to find the piece that is missing.

Step 4

Step 4: Write down relevant formulas

If step three didn't get you the answer, you must still be missing a piece of information. Writing down the formula is a way of both organizing your information and telling you what is missing. When you write your formulas down, fill in the information you have directly underneath the relevant part of the formula. It seems simple, but this way you can't make a mistake and finding the missing piece of information becomes a simple case of solving for x .

Step 5

Step 5: Drop heights/draw lines

If you're still stuck, you may need to manipulate or subdivide your shapes. If you have triangles, draw in the height. Have you created a 30-60-90? A 45-45-90? Or a Pythagorean triple? Try subdividing the shape or, if it's a three-dimensional figure, dashing in the hidden lines.

For more practice and a more in-depth look at The Princeton Review math techniques, check out our student-friendly guidebook, *Cracking the New GRE*.

DRILL 1
Question 1

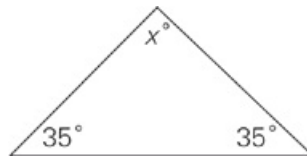

Quantity A

x

Quantity B

70

- Quantity A is greater.
- Quantity B is greater.
- The two quantities are equal.
- The relationship cannot be determined from the information given.

Question 2

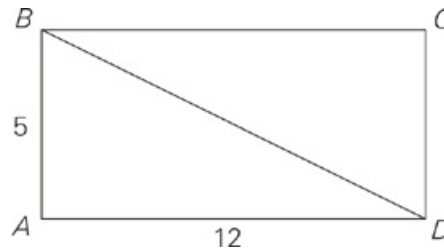

In the figure above, if ABCD is a rectangle, then what is the perimeter of $\triangle BCD$?

- 30
- 32
- 34
- 40
- 44

Question 3

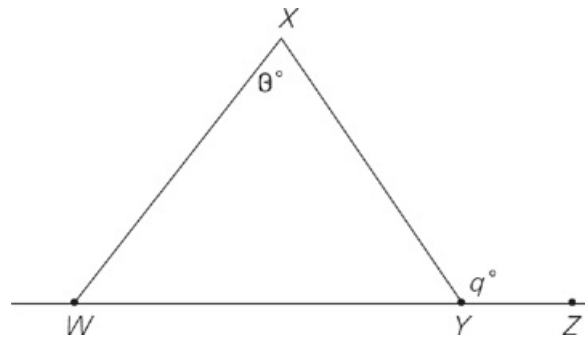

In the figure above, $WX = XY$ and points W, Y, and Z lie on the same line. What is the value of q ?

Question 4

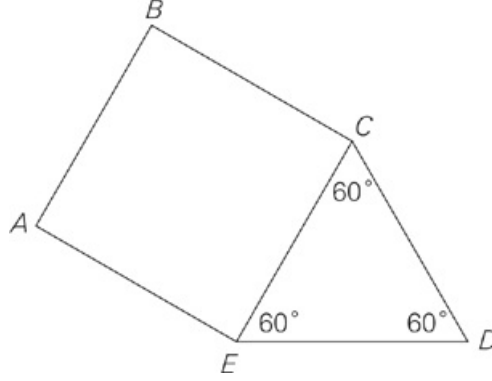

In square ABCE, $AB = 4$.

Quantity A

24

Quantity B

The perimeter of polygon ABCDE

- Quantity A is greater.
- Quantity B is greater.
- The two quantities are equal.
- The relationship cannot be determined from the information given.

Question 5

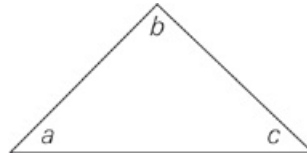

In the figure above, what is the value of $\frac{a + b + c}{30}$?

- 4
- 6
- 8
- 10
- 16

Question 6

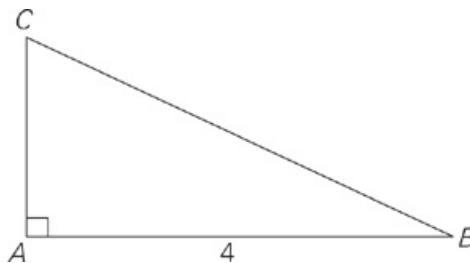

The length of line segment AC is $\frac{3}{4}$ the length of line segment AB.

Quantity A

BC

Quantity B

6

- Quantity B is greater.
- The two quantities are equal.
- The relationship cannot be determined from the information given.

Question 7

A ship captain sails 500 miles due south and then 1,200 miles due east.

Quantity A

1,350 miles

Quantity B

The minimum number of miles the captain must sail to return to his original position

- Quantity A is greater.
- Quantity B is greater.
- The two quantities are equal.
- The relationship cannot be determined from the information given.

Question 8

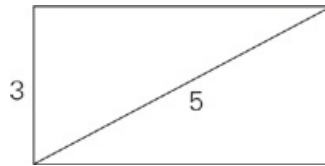

What is the area of the rectangle shown above?

- 4
- 6
- 8
- 10
- 12

Question 9

In triangle ABC, side AB has a length of 12, and side BC has a length of 5.

Quantity A

The length of side AC

Quantity B

7

- Quantity A is greater.
- Quantity B is greater.
- The two quantities are equal.
- The relationship cannot be determined from the information given.

Question 10

A hiker left her tent and traveled due east for 5 miles, then traveled due south for 24 miles, then due east for 5 miles, arriving at a hut. What is the straight-line distance from her tent to the hut?

- 20
- 26
- 28
- 29

Question 11

Two sides of a triangle are 4 and 8. Which of the following is a possible length of the third side of the triangle? Indicate all possible values.

- 3
- 4
- 5
- 6
- 7
- 8
- 12

Question 12

Triangle ABC is not equilateral, and angle ABC = 60 degrees.

Quantity A

Quantity B

The angle opposite the shortest side of the triangle

60 degrees

- Quantity A is greater.
- Quantity B is greater.
- The two quantities are equal.
- The relationship cannot be determined from the information given.

Question 13

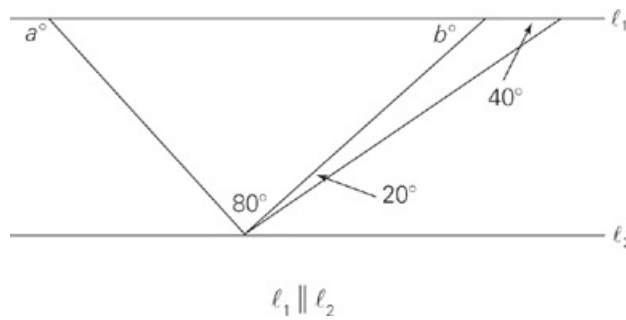

Quantity A

Quantity B

$a + b$

200

- Quantity A is greater.
- Quantity B is greater.

- The relationship cannot be determined from the information given.

Question 14

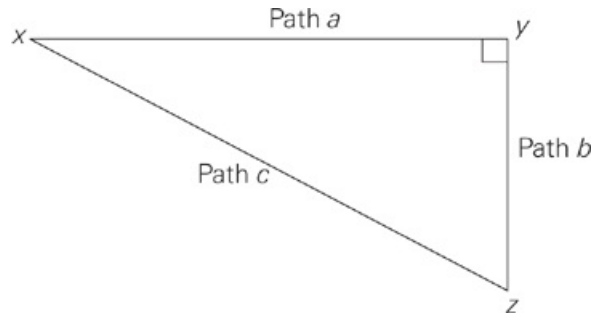

John and James walk from point x to point z (shown in the figure above). John walks directly from x to y on Path a and then directly from y to z on Path b. James walks directly from x to z on Path c. If Path a is 13 miles long and Path b is 5 miles long, John walks about how many miles longer than James?

- 2
- 3
- 4
- 5
- 6

Question 15

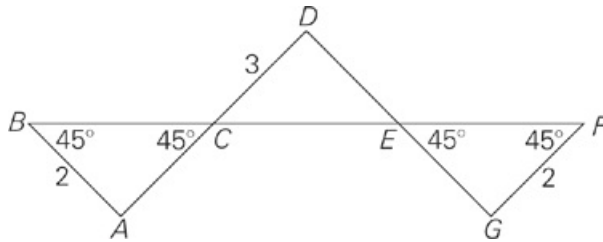

Quantity A

BF

Quantity B

$7\sqrt{2}$

- Quantity A is greater.
- Quantity B is greater.
- The two quantities are equal.
- The relationship cannot be determined from the information given.

DRILL 2
Question 1

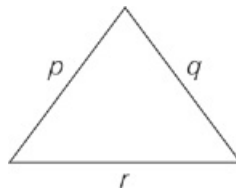

Quantity A

$$r$$

Quantity B

$$p + q - 1$$

- Quantity A is greater.
- Quantity B is greater.
- The two quantities are equal.
- The relationship cannot be determined from the information given.

Question 2

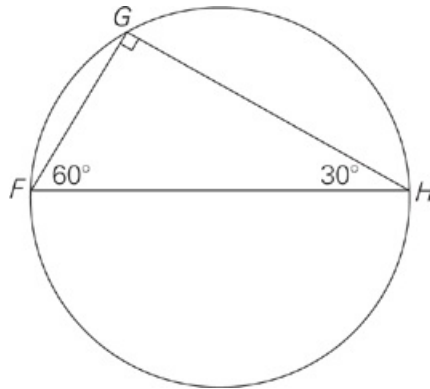

In the figure above, $FG = 4$, and FH is a diameter of the circle. What is the area of the circle?

- 4π
- 8π
- 12π
- 16π
- 20π

Question 3

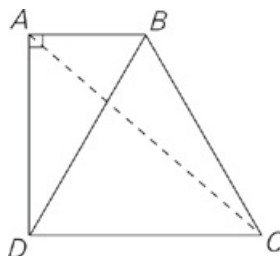

Quantity A

$$(AB)^2 + (AD)^2$$

Quantity B

$$(AC)^2$$

- Quantity A is greater.
- Quantity B is greater.
- The two quantities are equal.
- The relationship cannot be determined from the information given.

Question 4

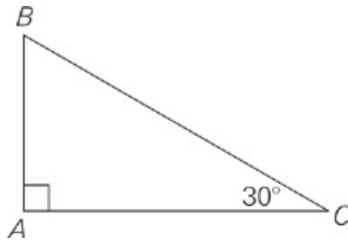

If the area of the above triangle is $8\sqrt{3}$, what is the length of side AB?

- 3
- 4
- $4\sqrt{3}$
- $6\sqrt{3}$
- $8\sqrt{3}$

Question 5

Mei is building a garden in the shape of an isosceles triangle with one side of 10. If the perimeter of the garden is 32, which of the following is a possible area of the garden?

- 32
- 48
- 50
- 60
- 64

Question 6

Quantity A

The area of an equilateral triangle with a side length of 4

Quantity B

The area of an isosceles right triangle with a hypotenuse of $4\sqrt{2}$

- Quantity A is greater.
- Quantity B is greater.
- The two quantities are equal.
- The relationship cannot be determined from the information given.

Question 7

Quantity A

The distance between Towns B and C

Quantity B

60 miles

- Quantity A is greater.
- Quantity B is greater.
- The two quantities are equal.
- The relationship cannot be determined from the information given.

Question 8

Point A is both in the interior of triangle B and on line C. If A, B, and C are in the same plane, in how many places does line C intersect triangle B?

- Zero
- One
- Two
- Three
- Five

Question 9

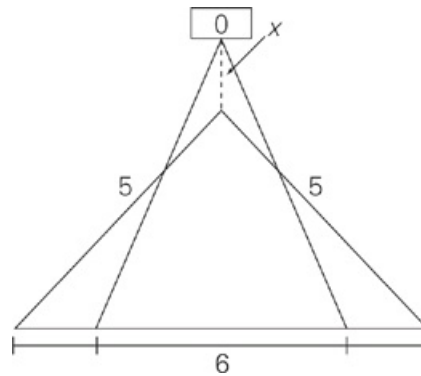

A photographer is using a tripod to steady his camera while taking pictures, as shown in the figure above. The legs of the tripod are 5 feet long and are currently 6 feet apart. If he pulls the legs another 2 feet apart, the top of the tripod drops x feet.

Quantity A

1

Quantity B

x

- Quantity A is greater.
- Quantity B is greater.
- The two quantities are equal.
- The relationship cannot be determined from the information given.

Question 10

If triangle ABC is equilateral and side AB has a length of s , then what is the area of triangle ABC in terms of s ?

- $\frac{s^2\sqrt{3}}{4}$

- $\frac{s^2\sqrt{3}}{2}$
- $\frac{s^2\sqrt{2}}{2}$
- $s\sqrt{3}$
- $s\sqrt{2}$

Question 11

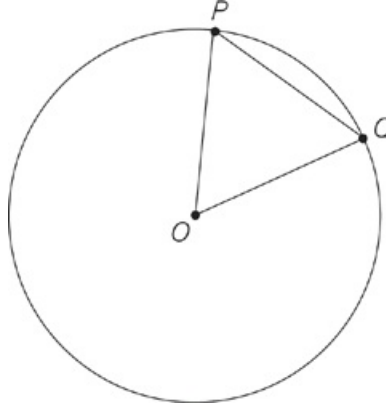

In the figure above, equilateral triangle OPQ is inscribed in the central angle of the circle and has perimeter 18. What is the area of circle O ?

- 6π
- 12π
- 18π
- 36π
- 72π

Question 12

Quantity A

The length of the side of a square with diagonal $\sqrt{50}$

Quantity B

The height of an equilateral triangle with side 6

- Quantity A is greater.
- Quantity B is greater.
- The two quantities are equal.
- The relationship cannot be determined from the information given.

Question 13

In a triangle, one angle is twice as large as the smallest angle, and another angle is three times as large as the smallest angle. What is the measure of the largest angle?

- 30°
- 45°
- 60°

75°

90°

Question 14

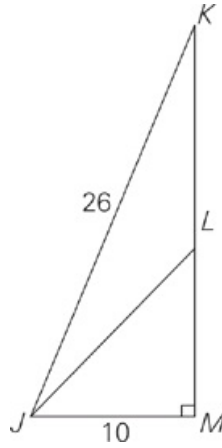

The area of $\triangle JKL$ is 65.

Quantity A

KL

Quantity B

LM

- Quantity A is greater.
- Quantity B is greater.
- The two quantities are equal.
- The relationship cannot be determined from the information given.

Question 15

Given four rods of length 1 meter, 3 meters, 5 meters, and 7 meters, how many different triangles can be made using one rod for each side?

- 6
- 4
- 3
- 2
- 1

DRILL 3

Question 1

How much greater, in square inches, is the area of a square with a diagonal of 8 inches than the area of a square with a diagonal of 4 inches?

- 4
- 24
- 32
- 48
- 96

Question 2

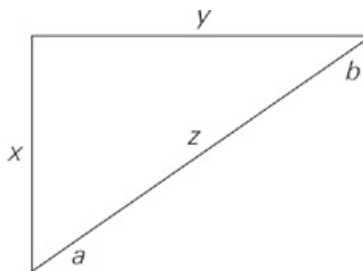

In the rectangle above, $a - b > b - a$.

Quantity A

$$z^2 - 2x^2$$

Quantity B

$$0$$

- Quantity A is greater.
- Quantity B is greater.
- The two quantities are equal.
- The relationship cannot be determined from the information given.

Question 3

The image of a star is projected onto a planetarium wall by a projector that sits atop a vertical 4-foot stand. If the projector is directed 30 degrees above the horizontal, and the image appears 16 feet above the level floor of the planetarium, then, in feet, how far is the projector from the wall?

- $12\sqrt{2}$
- $12\sqrt{3}$
- $16\sqrt{2}$
- $16\sqrt{3}$
- 24

Question 4

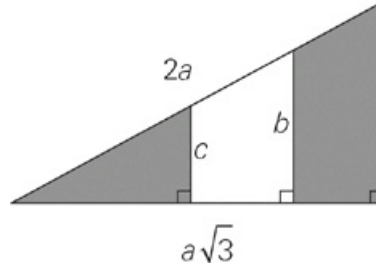

What is the area of the shaded region in the figure above, in terms of a , b , and c ?

- $\sqrt{3}(a^2 + b^2 + c^2)$
- $\frac{\sqrt{3}}{2}(a^2 - b^2 - c^2)$
- $\frac{\sqrt{3}}{2}(a^2 - b^2 + c^2)$
- $\frac{\sqrt{3}}{2}(a^2 + b^2 - c^2)$
- $\frac{\sqrt{3}}{2}(a^2 + b^2 + c^2)$

Question 5

A boat travels due east for 3 kilometers, makes a right turn and heads due south for 12 kilometers, and finally makes a left turn and travels due east again for 6 more kilometers. What is the distance between the boat's starting and ending locations?

Question 6

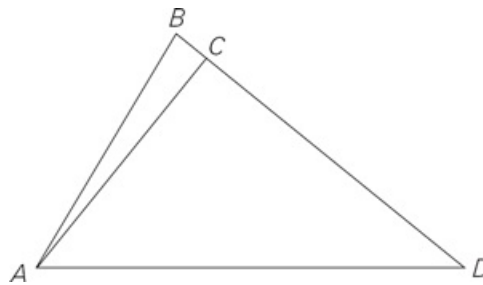

In triangle ABD pictured above, $\overline{AC} = 4$ and is perpendicular to \overline{BD} , which is equal to 125% the length of \overline{AC} . What is the area of triangle ABD?

Question 7

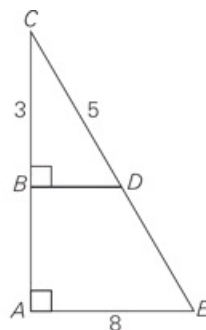

If BC is 3, CD is 3, and AE is 8, what is DE ?

- 3
- 4
- 5
- 6
- 10

Question 8

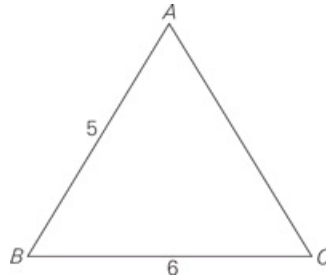

$\triangle ABC$ above is an isosceles triangle in which $AB = AC$. What is the area of $\triangle ABC$?

- 30
- 24
- 20
- 15
- 12

Question 9

A triangle has sides measuring 7 cm and 12 cm. Which of the following are possible values for the perimeter of the triangle? Indicate all possible values.

- 22 cm
- 24 cm
- 26 cm
- 28 cm
- 30 cm
- 34 cm
- 38 cm

Question 10

In right triangle LMN, the ratio of the longest side to the shortest side is 5 to 3. If the area of LMN is between 50 and 150, which of the following could be the length of the shortest side?

Indicate all possible values.

- 3
- 6
- 9

- 12
- 15
- 18

Question 11

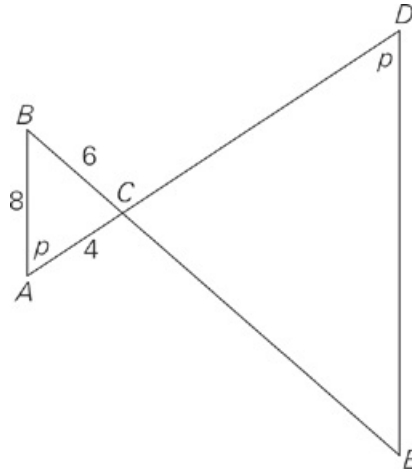

Note: Figure not drawn to scale

Which of the following are possible side lengths of triangle CDE?
Indicate all possible values.

- 2, 3, and 4
- 6, 8, and 10
- 6, 8, and 14
- 8, 12, and 16
- 12, 15, and 20
- 16, 24, and 32
- 16, 24, and 40

Question 12

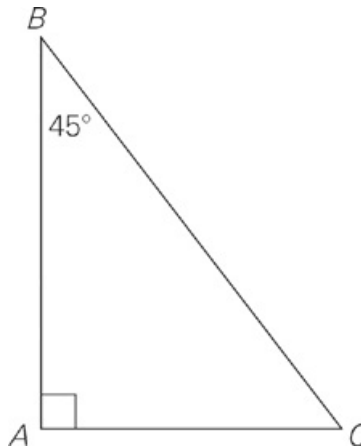

In the figure above, $BC = 8$. What is the area of triangle ABC?

Question 13

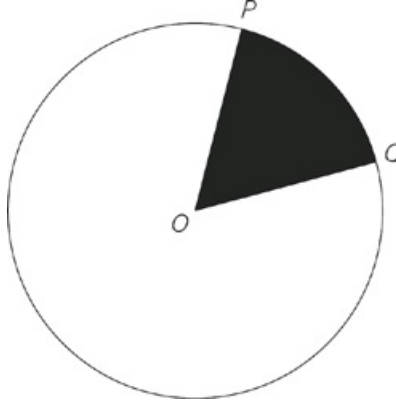

The circle above has center O and circumference 12π . If $\angle POQ = 30^\circ$, what is the area of the unshaded region?

Question 14

A parabola follows the function $f(x) = x^2 - 7x + 3$. Point A lies on the parabola at $(2, s)$, and point B lies on the parabola at $(6, t)$. What is the distance from A to B, rounded to the nearest hundredths place?

Question 15

Floyd is planting a garden in a triangular plot. One side of the plot measures $5\sqrt{3}$, and a second side measures $7\sqrt{11}$. Which of the following are possible values for the third side of the garden?

Indicate all possible values.

- $6\sqrt{2}$
- $8\sqrt{3}$
- $11\sqrt{5}$
- $17\sqrt{3}$
- $26\sqrt{2}$
- $17\sqrt{7}$

ANSWERS

Drill 1

1. A
2. A
3. 105
4. A
5. B
6. B
7. A
8. E
9. A
10. C
11. C, D, E, F
12. B
13. C
14. C
15. C

Drill 2

1. D
2. D
3. D
4. B
5. B
6. B
7. A
8. C
9. C
10. A
11. D
12. B
13. E
14. A
15. E

Drill 3

1. B
2. B
3. B
4. C
5. 15
6. 10
7. C
8. E
9. C, D, E, F
10. C, D
11. A, D, F
12. 16
13. 33p
14. 5.66
15. C, D

Drill 1

1. A The interior angles of a triangle add up to 180° , therefore, $x = 110$.
2. A In a rectangle, opposite sides are equal, and each angle measures 90 degrees. Triangle ABD is a 5-12-13 right triangle, so $BD = 13$. Furthermore, $BC = 12$, and $CD = 5$. To find the perimeter of any figure, add the lengths of the sides. In this case, $5 + 12 + 13 = 30$, so the answer is choice (A).
3. 105 There are 180 degrees in both a straight line and a triangle. In the figure, $\angle XWY$ and $\angle XYW$ are congruent and their measures add up to $180^\circ - 30^\circ = 150^\circ$, so each angle measures 75° . A straight line measures 180° , so $q = 180 - 75 = 105$.
4. A $\triangle CDE$ has equal angles, so it is equilateral. ABCE is also equilateral, as are all squares. To find the perimeter of any figure, add up all of the side lengths on the outside of the figure. In this case, 5 equal segments of length 4 result in a perimeter of 20, so Quantity A is greater.
5. B All three angles of the triangle add up to 180° . 30 goes into 180 six times. The answer is choice (B).
6. B AC has a length of 3, so you can use Pythagorean theorem, or recognize the Pythagorean triple, to find that BC has a length of 5. The answer is choice (B).
7. A Draw a right triangle representing the captain's route so far and the path back to his starting point:

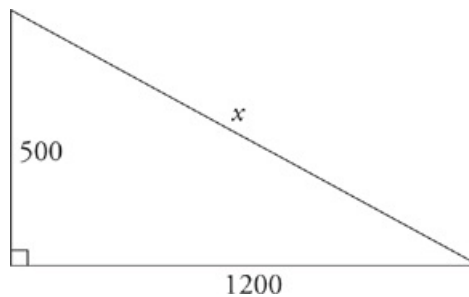

A right triangle with legs of 500 and 1,200 is a multiple of the familiar 5-12-13 triangle, so the hypotenuse—and the number of miles the captain must sail to return to his original position—is 1,300. The answer is choice (A).

8. E Recognize the 3-4-5 triple or use the Pythagorean theorem to find that the missing side length of the rectangle is 4. The area of the rectangle is $bh = 3 \times 4 = 12$, so the answer is choice (E).
9. A The Third Side Rule states that the third side in any triangle must be shorter than the sum of, and longer than the difference between, the other two sides. Hence, the third side of this triangle must be greater than 7, and less than 17. Quantity A is greater.
10. C First, draw the picture (see below). Notice that this makes two right triangles, each with legs of 5 and 12. Either recognize the 5-12-13 triple or use the Pythagorean theorem to see that the distance is $13 + 13 = 26$.

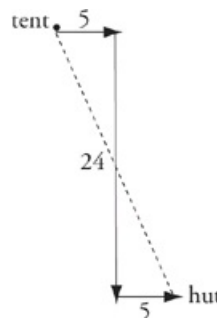

11. C, D, E, and F
The Third Side Rule states that the third side of any triangle must be greater than the difference between the other two sides and less than the sum of the other two sides. Therefore, the third side of the triangle in the question must be between 4 and 12, and you can eliminate any choices outside this range. The only choices in this range are 5, 6, 7, and 8, the correct answers.
12. B The smallest angle in a triangle is always opposite the shortest side. If angle ABC is 60 degrees, the other two angles total $180^\circ - 60^\circ = 120^\circ$. The triangle isn't equilateral, the remaining two angles cannot both be 60° . Therefore, the smaller angle must be less than 60° , and Quantity B is greater.
13. C Start by finding the remaining angles of the triangle on the right: If the two small angles add up to $20^\circ + 40^\circ = 60^\circ$, then the unmarked angle must be 120° , and b must be 60. The remaining angle in the triangle on the left must be 40° , and a must be 140. So Quantity A is $140 + 60 = 200$; the quantities are equal.

14. C Use the Pythagorean theorem to find the length of path C: $5^2 + 13^2 = c^2$. So path c is approximately 14 miles. John walks 18 miles, and James walks 14 miles, so the answer is choice (C).
15. C Although the figure may look complex, it's really just three 45-45-90 triangles attached end-to-end; BF is the sum of the long sides of the three triangles. If AB = 2, then AC = 2, and BC = $2\sqrt{2}$; similarly, EG and FG are 2, and EF = $2\sqrt{2}$. Two of the angles in triangle DCE are vertical angles with 45° angles in the other two triangles, so it must be a 45-45-90 triangle also—the legs are each 3, so CE = $3\sqrt{2}$. So $BF = 2\sqrt{2} + 2\sqrt{2} + 3\sqrt{2} = 7\sqrt{2}$; the quantities are equal.

- D According to the Third Side Rule, r must be less than the sum of p and q . Plug In to test if r is less than $p + q - 1$. Let $p = 5$ and $q = 4$. If $r = 2$, Quantity A is 2 and Quantity B is 8; Quantity B is greater, so eliminate choices (A) and (C). However, a value of 8 for r would also satisfy the Third Side Rule; now the quantities are equal, so eliminate choice (B) and select choice (D).
- D This is a 30-60-90 triangle, so $FH = 8$. If the diameter is 8, then the radius is 4, so the area is 16π .
- D Although the Pythagorean theorem dictates that $(AB)^2 + (AD)^2$ —the sum of the squares of two sides of a right triangle—is equal to the square of the hypotenuse, or $(BD)^2$, there's no way to determine the relationship between $(BD)^2$ and $(AC)^2$. Remember, figures are not drawn to scale on the GRE: Although it looks like AC is longer than BD , it's possible to redraw the figure so that either segment is longer; try varying the length of DC .
- B Plug in the answers, and be sure to note that this is a 30-60-90 triangle. In choice (B), if AB is 4 and AC is $4\sqrt{3}$, then the area is $\frac{1}{2}(4)(4\sqrt{3}) = 8\sqrt{3}$. So the answer is choice (B).
- B If the triangle is isosceles, it must have two equal sides; thus, the triangle could have sides of 10, 10, and 12 or sides of 10, 11, and 11. To find one of the possible areas, draw out your 10-10-12 triangle. With the height drawn in, it should look like this:

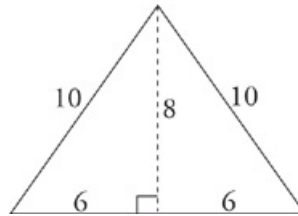

Note that the big triangle divides nicely into two of the familiar 6-8-10 triangles; you now have a triangle with a base of 12 and a height of 8, so the area is $\frac{1}{2} \times 12 \times 8 = 48$. The answer is choice (B).

- B In Quantity A, an equilateral triangle with a side length of 4 has a base of 4 and a height of $2\sqrt{3}$: remember, an equilateral triangle cut in half yields two 30-60-90 triangles. Thus, the triangle has an area of $\frac{1}{2} \times 4 \times 2\sqrt{3}$, or $4\sqrt{3}$. Remember that $\sqrt{3}$ is approximately 1.7, so $4\sqrt{3}$ is about 6.8. In Quantity B, “isosceles right triangle” means 45-45-90, so a long side of $4\sqrt{2}$ yields a base and a height both equal to 4, and an area of $\frac{1}{2} \times 4 \times 4$, or 8. Quantity B is greater.
- A If the towns do not lie on a straight line, they must lie on a triangle; Quantity A represents the third side of the triangle. According to the Third Side Rule this side must be greater than the difference between, and less than the sum of, of the other two sides. Thus, Quantity A lies between $110 - 40 = 70$ miles and $110 + 40 = 150$ miles, but is always greater than 60 miles; the answer is choice (A).
- C Draw a triangle with a point inside. Draw a line through the point to see how many places the line intersects with the triangle. There are many ways to draw the line, but each way intersects the triangle at two points.
- C Split the initial triangle into two right triangles. The figure should look like this:

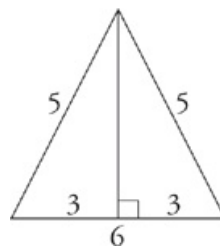

The smaller triangles are the familiar 3-4-5 triangles, with a height of 4. When the photographer pulls the legs another 2 feet apart, your figure looks like this:

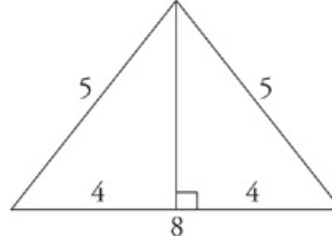

Again, the smaller triangles are 3-4-5 triangles, but now the height is 3. Because x is the change in the triangle's height, $x = 1$, so the quantities are equal.

10. A First, draw your figure and write out the area formula for triangles, $A = \frac{1}{2}bh$. Then, plug in a number for s ; try $s = 6$. In order to find the height of an equilateral triangle, you need to draw an altitude from the top vertex down the middle to the opposite base, creating two 30-60-90 right triangles. The height of this equilateral triangle is $3\sqrt{3}$, so the area formula is $\frac{1}{2} \times (6) \times (3\sqrt{3}) = 9\sqrt{3}$. Now plug 6 in for s in the answer choices. Eliminate choices (C) and (E) because they have the wrong root. Of the remaining answers, only choice (A) yields the target answer of $9\sqrt{3}$: $\frac{s^2}{4}\sqrt{3} = \frac{36}{4}\sqrt{3} = 9\sqrt{3}$.
11. D The triangle is equilateral, so dividing the perimeter by 3 gives you the length of 6 for each side. Angle POQ is the central angle of the circle, so sides OP and OQ are also radii of the circle. Thus, the area of the circle is $\pi r^2 = \pi 6^2 = 36\pi$, so the answer is choice (D).
12. B A square cut in half from corner to corner yields two 45-45-90 triangles, so a diagonal of $\sqrt{50}$ —also known as $5\sqrt{2}$ —gives a side of 5. The height of an equilateral triangle splits it into two 30-60-90 triangles, so a side of 6 gives a height of $3\sqrt{3}$. To compare, express both sides as square roots: 5 is equal to $\sqrt{25}$, and $3\sqrt{3}$ is equal to $\sqrt{27}$. Quantity B is greater.
13. E If x is the measure of the smallest angle, then the other two angles are $2x$ and $3x$. The sum of the angles is 180° , so $x + 2x + 3x = 180$. Solve the equation to find $x = 30$, which means the largest angle measures 90° .
14. A Triangle JKM is the familiar 5-12-13 triple, but doubled, so $KM = 24$. KL may look the same length as LM, but remember that figures are not drawn to scale. In any triangle, the height is always measured perpendicular to the base from the opposite vertex. So the height of triangle JKL is the length of JM, 10. You are given the area of triangle JKL, so plug all the information you know into the area formula for triangles: $A = \frac{1}{2}bh$; $65 = \frac{1}{2}(KL)(10)$; $KL = 13$. Subtracting KL from KM gives you LM: $24 - 13 = 11$; $LM = 11$. Quantity A is 13, and Quantity B is 11, so the answer is choice (A).
15. E According to the Third Side Rule for triangles, the longest side of a triangle must be shorter than the sum of the other two sides. Write out all the possible combinations of sides: 1, 3, 5; 1, 3, 7; 3, 5, 7; 1, 5, 7. The only possible combination of sides that obeys the Third Side Rule is 3, 5, 7.

1. B Draw your own figures. The diagonal of a square creates 45-45-90 triangles with sides in the ratio of $x : x : x\sqrt{2}$. So, the larger square has a diagonal of $x\sqrt{2} = 8$. Divide by $\sqrt{2}$ to find the side length, $\frac{8}{\sqrt{2}}$. The area is $\left(\frac{8}{\sqrt{2}}\right)^2 = 32$. The smaller square has a diagonal of $x\sqrt{2} = 4$. Divide by $\sqrt{2}$ to find the side length, $\frac{4}{\sqrt{2}}$. The area is $\left(\frac{4}{\sqrt{2}}\right)^2 = 8$. The area of the larger square is $32 - 8 = 24$ greater than that of the smaller square.
2. B Manipulate $a - b > b - a$ to get $a > b$; hence y , which is the same length as the side across from b , is shorter than x , which is the same length as the side across from a . The diagonal divides the rectangle into two right triangles. According to the Pythagorean theorem, $z^2 = x^2 + y^2$, so $z^2 - x^2 - y^2 = 0$ because $x > y$, $x^2 > y^2$. So in Quantity A you are subtracting more than $x^2 - y^2$ from z^2 . Therefore, $z^2 - 2x^2 < 0$, so the answer is choice (B).
3. B Draw your figure as a right triangle atop a rectangle. The hypotenuse represents the path of the image on the wall, and the rectangle's dimensions represent the height of the stand and its distance from the wall. It should look like this:

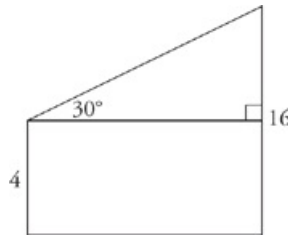

The triangle on top is a 30-60-90 triangle with a short side of $16 - 4 = 12$; so the side across from the other leg (the distance from the projector to the wall) is $12\sqrt{3}$ so the answer is choice (B).

4. C The ratio of the given leg to the hypotenuse is $\sqrt{3}$ to 2 in the largest right triangle, so it is a 30-60-90 triangle, and the length of the other leg must be a . The smaller two triangles also contain 90 degree angles, and all three triangles share the left vertex angle, making all three triangles similar with proportional sides. So, the horizontal leg of the smallest triangle is $cr\sqrt{3}$, and the horizontal leg of the medium sized triangle is $br\sqrt{3}$. To find the area of the shaded region, find the area of the large triangle, subtract the area of the medium sized one, and add back the area of the smallest one. Plug in values: $a = 4$, $b = 2$, $c = 1$. The area of the large triangle becomes $\frac{1}{2}(4\sqrt{3})(4) = 8\sqrt{3}$ The area of the medium triangle becomes $\frac{1}{2}(2\sqrt{3})(2) = 2\sqrt{3}$ The area of the smallest triangle becomes $\frac{1}{2}(\sqrt{3})(1) = \frac{\sqrt{3}}{2}$ The shaded area is $8\sqrt{3} - 2\sqrt{3} + \frac{\sqrt{3}}{2} = 6\sqrt{3} + \frac{\sqrt{3}}{2} = 6\frac{1}{2}\sqrt{3} = \frac{13\sqrt{3}}{2}$. When you plug in the three values into each answer, only choice (C) hits your target, making it the correct answer.

5. 15 To solve this question, picture a triangle:

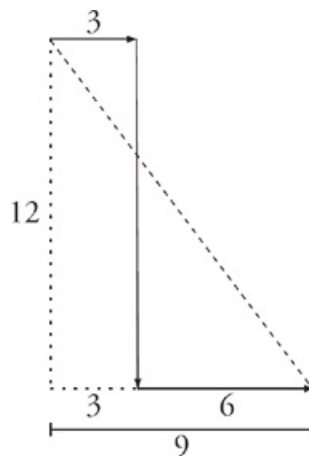

Since the boat travels a total of $3 + 6 = 9$ kilometers east, and a total of 12 kilometers south, we can use the Pythagorean theorem to find the total distance. Since $a^2 + b^2 = c^2$, then $9^2 + 12^2 = c^2$, and $81 + 144 = 225 = c^2$. Taking the square root of both sides

gives that $c = 15$, the correct answer.

6. 10 To solve this question, label everything. First label angle ACD as a right angle. Next, label $\overline{AC} = 4$. If $\overline{BD} = 125\%$ of \overline{AC} , then $\overline{BD} = \frac{125}{100} \times 4 = \frac{5}{4} \times 4 = 5$. Since \overline{AC} and \overline{BD} are perpendicular, \overline{BD} can be the base and \overline{AC} can be the height. Since the formula for the area of a triangle is $\text{Area} = \frac{1}{2}bh$ the area here equals $\frac{1}{2} \times 5 \times 4 = 10$ the correct answer is 10.
7. C This question is testing similar triangles. Do you recognize the 3-4-5 triangles? Triangle BCD is a 3-4-5 triangle, and triangle ACE is too, but it's a similar triangle—a 6-8-10 triangle. That means that CE is 10, which leaves 5 left over for DE.
8. E To find the area of this triangle, you must drop a line segment to make the height. If you call the midpoint of BC point X, you know that BX is equal to 3. If you see that this makes a right triangle with a side of 3 and a hypotenuse of 5, you can use the 3-4-5 triangle rule to get 4 for the height. Otherwise, use the Pythagorean theorem. After you find the height of 4, use the formula for area of a triangle. The base, 6, multiplied by the height, 4, gives you 24. Divide by 2 to get 12.
9. C, D, E, and F
The Third Side Rule tells you that the third side must be more than the difference of the two other sides and less than their sum. Therefore, the third side must be greater than 5 and less than 19. The two known sides already add up to 19. If you add this to the range for the third side, the perimeter of the triangle is then between 24 and 38 centimeters. Choices (C), (D), (E), and (F) correct.
10. C and D
Draw and label the figure, and then set up your scratch paper to plug in the answers. For a given short side, use the 5:3 ratio to find the long side, and use either the Pythagorean theorem or multiples of the familiar 3-4-5 triangles to determine the middle side; since LMN is a right triangle, the two shorter sides can be used as base and height to find the area. Start with choice (C). If the short side is 9, the middle side is 12 and the area becomes 54; this choice is correct, but just barely, and if you try smaller values you will fall out of the area's range. Eliminate choices (B) and (A). In choice (D), the short and middle sides are 12 and, 16 and the area is 96; this choice is correct. In choice (E), the short and middle sides are 15 and 20, and the area is 150. This is not in the area's range of 50 to 150, so eliminate it as well as choice (F), which would produce an even larger area. The correct answers are choices (C) and (D).
11. A, D, and F
Triangles ABC and CDE are similar triangles: The angles where the triangles meet are equal, as are the angles marked j° , so the remaining angles must be equal as well. Since similar triangles have proportional sides, any answer choice in the ratio of 4:6:8 will work. Choice (A) is 4:6:8 cut in half, so choice (A) works; remember the figure isn't drawn to scale, so don't worry about making CDE smaller than ABC. Choices (D) and (F) are 4:6:8 multiplied by 2 and 4, respectively, so both work as well. None of the remaining choices work: Choices (C) and (G), in fact, violate the Third Side Rule and aren't even triangles.
12. 16 According to the information given, this must be a 45-45-90 isosceles right triangle, and the relationship between the sides can be written as $x\sqrt{2}$. That means that $BC = x\sqrt{2}$, or $8 = x\sqrt{2}$. Solving for x , you get $x = \frac{8}{\sqrt{2}}$, so each of the legs of the triangle is equal to $\frac{8}{\sqrt{2}}$. The formula for the area of a triangle is $\frac{1}{2}(\text{base}) \times (\text{height})$, so the area of this triangle is $\frac{1}{2} \left(\frac{8}{\sqrt{2}} \right) \left(\frac{8}{\sqrt{2}} \right) = \frac{64}{4} = 16$.
13. 33π The formula for the circumference of a circle is $\text{circumference} = 2\pi r$, so if the circumference is 12π , then the radius must be 6. The formula for the area of a circle is $\text{area} = \pi r^2$ so the area of the circle is 36π . From the question you know that $\angle POQ = 30^\circ$. The entire circle has 360° , so the shaded region takes up $\frac{30^\circ}{360^\circ} = \frac{1}{12}$ of the entire circle. $(36\pi) \times \left(\frac{1}{12} \right) = 3\pi$, so the area of the shaded region is 3π . The shaded area formula is $\text{total area} - \text{shaded area} = \text{unshaded}$, so you have $36\pi - 3\pi = 33\pi$.
14. 5.66
Don't worry if the parabola seems unfamiliar—it's really just providing you with a way to find the y-values for the given x-values. Plugging 2 in for x gives you -7 for y, so point A is located at (2, -7); using the same process, you can find that point B is located at (6, -3). Plot the two points on a coordinate grid, and make a right triangle by adding a vertex at (2, -3) or (6, -7). Either way, you have a right triangle with short sides of 4, so it's a 45-45-90 triangle, and the long side is $4\sqrt{2}$. Use your on-screen calculator to determine the final approximate value, 5.66.
15. C and D
First calculate values for $5\sqrt{3}$ and $7\sqrt{11}$: The first is approximately 8.66, and the second is approximately 23.22. The third side of a triangle must be greater than the difference of the other two sides and less than the sum of the other two sides; hence, the third side of the garden must measure between 14.56 and 31.88. Calculating for the value of the roots, you will find that only choices (C) and (D) fall within this range.



Circles

CIRCLES

There are only three formulas you will need to solve circle problems.

$$\pi r^2, 2\pi r \text{ or } \pi d, \text{ and}$$
$$\frac{\text{angle}}{360} = \frac{\text{arc}}{\text{circumference}} = \frac{\text{area sector}}{\text{area circle}}$$

The radius is involved in all three formulas. Once you have the radius of a circle, you will know almost everything there is to know about that circle.

πr^2 measures the area of a circle. It's easy to remember because area, such as the area of a house or apartment, is always measured in units squared.

πd or $2\pi r$ measures circumference. If you know circumference, you know the radius, and if you know the radius you know the area. Most GRE circle questions ask you to find one or the other or require you to convert from one to the other. You must be able to do these tasks quickly and easily. If you write the formulas down on your scratch paper and fill in the information from the question directly underneath the relevant part of the formula, finding the answer shouldn't be a problem.

$\frac{\text{angle}}{360} = \frac{\text{arc}}{\text{circumference}} = \frac{\text{area sector}}{\text{area circle}}$ is one formula that they don't give you in any of the official GRE literature, but it can come in handy. It essentially means that angles, arcs, and areas are all proportional. If you were to divide a circle into quarters, the central angle—90 over 360—reduces to $\frac{1}{4}$. The resulting arc is $\frac{1}{4}$ of the circumference of the circle and the area of the sector is $\frac{1}{4}$ the area of the circle.

Pi, or π , equals 3.14159 ... or 3 and change. If you are given a circle with a radius of 5 and asked for the area, set π equal to 3 and Ballpark. Eliminate any answer choice which is less than or equal to 75, or greater than or equal to 100. You know that the correct answer will be far closer to 75 than it will be to 100.

The five-step approach to geometry problems applies to circles as well.

Step 1

Step 1: Draw your shape

In some cases the test will give you a shape, which you may or may not be able to trust, and in others it will give you a word problem and leave it up to you to envision the shape. As with every other part of the test, getting your hand moving is an important first step to entering the problem. Get your shape down on your scratch paper so that you can begin working with it there. On Quant Comp questions involving geometry, instead of Plugging In more than once, you may have to draw your shape more than once.

Step 2

Step 2: Fill in what you know

Whether you are given the shape or not, you will be given a certain amount of information regarding the shape such as the measure of some angles, lengths of some sides, areas of some sides, or volume. Put that information in the figure.

Step 3

Step 3: Make deductions

If you are given two angles of a triangle, find the third. If you are given the radius of a circle, find the area. Often this will be the entire problem. Geometry on the GRE is all about finding the missing piece of information. You will be given just enough information to find the piece that is missing.

Step 4

Step 4: Write down relevant formulas

If step three didn't get you the answer, you must still be missing a piece of information. Writing down the formula is a way of both organizing your information and telling you what is missing. When you write your formulas down, fill in the information you have directly underneath the relevant part of the formula. It seems simple, but this way you can't make a mistake. Finding the missing piece of information becomes a simple case of solving for x .

Step 5

Step 5: Drop heights/draw lines

If you're still stuck, you may need to manipulate or subdivide your circle into smaller shapes. If create triangles, draw in the height. Have you created a 30-60-90? A 45-45-90? Or a Pythagorean triple? Try subdividing the shape or, if it's a three-dimensional figure, dashing in the hidden lines.

Often, you will see circles in combination with other shapes. If you don't immediately see the correct path to the solution, look for the radius. Everything about a circle derives from there. It is possible that you will see a circle inscribed on a coordinate plane. The same rules apply. Use right triangles to find the end points of as many radii as you need to check the answer choices that you can't eliminate through Ballparking.

For more practice and a more in-depth look at The Princeton Review math techniques, check out our student-friendly guidebook, *Cracking the New GRE*.

DRILL 1
Question 1

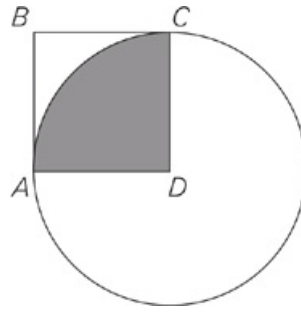

ABCD is a square with side length 2.

Quantity A

The area of the shaded region

Quantity B

π

- Quantity A is greater.
- Quantity B is greater.
- The two quantities are equal.
- The relationship cannot be determined from the information given.

Question 2

What is the degree measure of the smaller angle formed by the hands of a circular clock when it is 10:00?

Question 3

The area of circle C is 9π .

Quantity A

The radius of circle C

Quantity B

6

- Quantity A is greater.
- Quantity B is greater.
- The two quantities are equal.
- The relationship cannot be determined from the information given.

Question 4

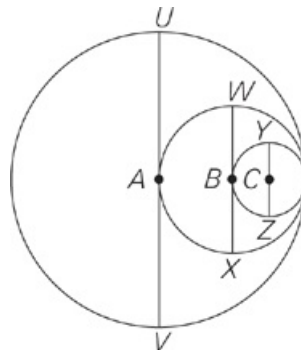

UV, WX, and YZ are diameters of the circles with centers A, B, and C, respectively. If $YZ = 2$, then what is the area of

the circle with center A?

- 4π
- 8π
- 9π
- 16π
- 64π

Question 5

Quantity A

The circumference of a circle with a diameter of 6

Quantity B

The circumference of a circle with a radius of 12

- Quantity A is greater.
- Quantity B is greater.
- The two quantities are equal.
- The relationship cannot be determined from the information given.

Question 6

Quantity A

Four times the area of a circular region with a circumference of 4π

Quantity B

The circumference of a circular region with an area of 64π

- Quantity A is greater.
- Quantity B is greater.
- The two quantities are equal.
- The relationship cannot be determined from the information given.

Question 7

An office needs to buy circular pizzas for 20 employees. If each pizza is cut into equal slices, and each slice has a central angle of 40° , what is the minimum number of pizzas that need to be ordered so that each employee gets at least two slices of pizza?

Question 8

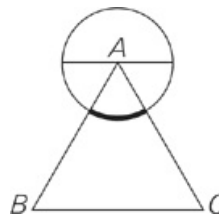

Triangle ABC is equilateral. If the circle with center A has a diameter of 6, what is the length of the darkened arc?

- $\frac{\pi}{2}$
- π

- 6
- 6π
- $6\sqrt{3}$

Question 9

A circle with center C has a radius of 6.

Quantity A

The ratio of the circumference of C to the radius of C

Quantity B

Half the diameter of C

- Quantity A is greater.
- Quantity B is greater.
- The two quantities are equal.
- The relationship cannot be determined from the information given.

Question 10

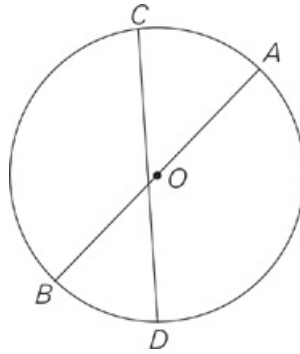

O is the center of the circle above.

Quantity A

Length of line segment AB

Quantity B

Length of line segment CD

- Quantity A is greater.
- Quantity B is greater.
- The two quantities are equal.
- The relationship cannot be determined from the information given.

Question 11

A circle of radius 3 is inscribed in a square. What is the product of the perimeter and area of the square?

Question 12

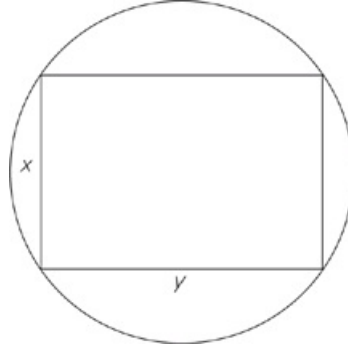

In the figure above, a rectangle is inscribed in a circle. Lengths x and y are both integers such that $x + y = 10$, and $1 < x < y$. Which of the following are possible values for the diameter of the circle?

Indicate all possible values.

- $\sqrt{10}$
- $\sqrt{2}$
- $2\sqrt{13}$
- $\sqrt{58}$
- $\sqrt{69}$
- $2\sqrt{17}$
- 10

Question 13

The height of a right circular cylinder is increased by p percent and the radius is decreased by p percent.

Quantity A

The volume of the cylinder if $p = 10$

Quantity B

The volume of the cylinder if $p = 20$

- Quantity A is greater.
- Quantity B is greater.
- The two quantities are equal.
- The relationship cannot be determined from the information given.

Question 14

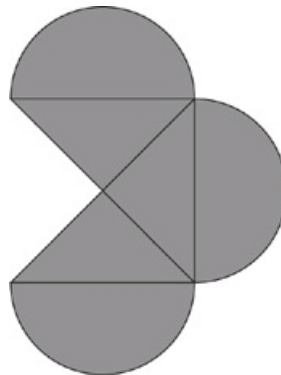

The diameters of the semicircles above are 8, and the diameter of the semicircle on the right is perpendicular to those of the other two semicircles. What is the total area of the shaded region?

- $12\pi + 64$
- $24\pi + 12$
- $24\pi + 48$
- $32\pi + 48$
- $32\pi + 64$

Question 15

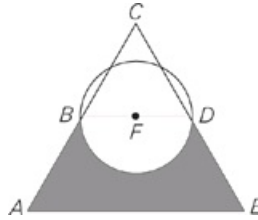

Triangle ACE is equilateral with side lengths of 8. Points B and D are the midpoints of line segments AC and CE respectively. Line segment BD is a diameter of the circle with center F. What is the area of the shaded region?

- $8\sqrt{2} - 4\pi$
- $12\sqrt{3} - 2\pi$
- $12\sqrt{3} - 4\pi$
- $16\sqrt{3} - 2\pi$
- $16\sqrt{2} - 4\pi$

Question 16

Quantity A

The area of a square with a perimeter of p

Quantity B

The area of a circle with a circumference of p

- Quantity A is greater.
- Quantity B is greater.
- The two quantities are equal.
- The relationship cannot be determined from the information given.

Question 17

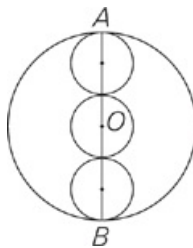

Line AB passes through the center of circle O and through the centers of each of the 3 identical smaller circles. Each circle touches two other circles at exactly one point each.

Quantity A

Quantity B

The circumference of circle O

The sum of the circumferences of the 3 smaller circles

- Quantity A is greater.
- Quantity B is greater.
- The two quantities are equal.
- The relationship cannot be determined from the information given.

DRILL 2

Question 1

A square has edges of length 12 inches.

Quantity A

24π

Quantity B

The area of the largest circle that can fit inside the square

- Quantity A is greater.
- Quantity B is greater.
- The two quantities are equal.
- The relationship cannot be determined from the information given.

Question 2

A circle with a circumference of 12π is divided into three sectors with areas in a ratio of 3:4:5. What is the area of the largest sector?

- 6π
- 9π
- 12π
- 15π
- 18π

Question 3

A circle is inscribed in a square with area 36. What is the area of the circle?



Question 4

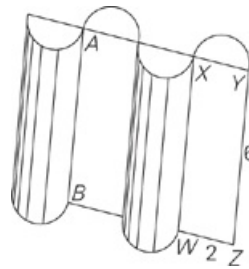

Rectangle WXYZ has a length of 6 and a width of 2. Rectangle AYZB bisects right cylinders ABC and D. If all the cylinders have the same radius, what is the combined volume of the four half-cylinders?

- 6π
- 9π
- 12π
- 18π
- 21π

Question 5

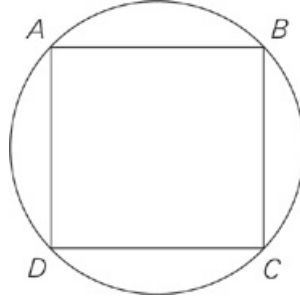

Inscribed square ABCD has a side length of 4. What is the area of the circle?

- 2π
- 4π
- 6π
- 8π
- 10π

Question 6

If the diameter of circle A is eight times that of circle B, what is the ratio of the area of circle A to the area of circle B?

- 4:1
- 8:1
- 16:1
- 32:1
- 64:1

Question 7

On a rectangular coordinate plane, a circle centered at $(0, 0)$ is inscribed within a square with adjacent vertices at $(0, -2\sqrt{2})$ and $(2\sqrt{2}, 0)$. What is the area of the region, rounded to the nearest tenth, that is inside the square but outside the circle?



Question 8

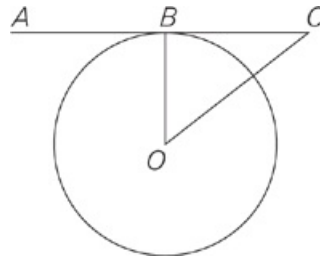

Line segment AC is tangent to the circle with center O and $CO = 5$.

Quantity A

Circumference of the circle

Quantity B

10π

- Quantity A is greater.
- Quantity B is greater.
- The two quantities are equal.

- The relationship cannot be determined from the information given.

Question 9

The area of Circle A is increased by a factor of x to create Circle B.
The area of Circle B is increased by a factor of x to create Circle C.

Quantity A

The ratio of the radius of Circle A to the radius of Circle C

Quantity B

$$\frac{1}{x}$$

- Quantity A is greater.
- Quantity B is greater.
- The two quantities are equal.
- The relationship cannot be determined from the information given.

Question 10

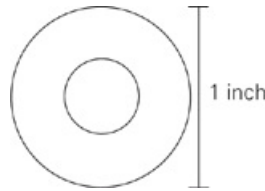

In the figure above, if the area of the smaller circular region is $\frac{1}{2}$ the area of the larger circular region, then the diameter of the larger circle is how many inches longer than the diameter of the smaller circle?

- $\sqrt{2} - 1$
- $\frac{1}{2}$
- $\frac{\sqrt{2}}{2}$
- $\frac{2 - \sqrt{2}}{2}$
- $\sqrt{2}$

Question 11

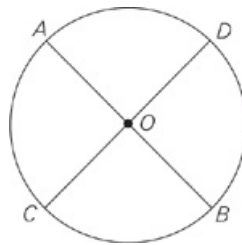

Quantity A

$AB + CD$

Quantity B

The circumference of the circle with center O

- Quantity A is greater.
- Quantity B is greater.

- The two quantities are equal.
- The relationship cannot be determined from the information given.

Question 12

Points A and B lie along the circumference of a circle with center O. A second circle with center M has a radius one-third as long as that of the circle with center O. If the area of sector AOB is equal to the area of the circle with center M, then what is the measure in degrees of $\angle AOB$?

Question 13

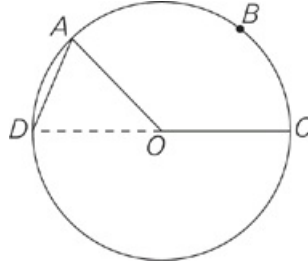

No line segment with endpoints on the circle with center O is longer than line segment DC.

$$OA = AD = 3$$

Quantity A

The area of sector OABC

Quantity B

9

- Quantity A is greater.
- Quantity B is greater.
- The two quantities are equal.
- The relationship cannot be determined from the information given.

Question 14

An interior designer decides to accent a wall with an evenly spaced row of stenciled circles. The wall is 31'6" long and the stencil has an area of 36π square inches. If the designer wants to leave a space of x inches between each circle and at either end of the row, and x is an integer, then what is the greatest possible number of circles that the designer can use?

Question 15

$\frac{1}{r}$ of a circular pizza has been eaten. If the rest of the pizza is divided into m equal slices, then each of these slices is what fraction of the whole pizza?

- $\frac{r}{m}$
- $\frac{r-1}{m}$
- $\frac{1}{m}$
- $\frac{m-1}{m}$

$\frac{m-r}{m}$

Question 16

A single slice cut from the center of a circular pizza has an edge length (from the center of the pizza to the edge of the crust) of 5", has an arc length of 1.25π ", and weighs 4 ounces. If a serving weighs 8 ounces, then, to the nearest integer, what is the largest number of servings that six 6" diameter pizzas can yield? (Note that servings must weigh 8 ounces, but they do not need to be equal in shape.)

- 1
- 4
- 6
- 8
- 9

ANSWERS

Drill 1

1. C
2. 60
3. B
4. D
5. B
6. C
7. 5
8. B
9. A
10. A
11. 864
12. C, D, F
13. A
14. C
15. B
16. B
17. C

Drill 2

1. B
2. D
3. 9π
4. C
5. D
6. E
7. 3.4
8. B
9. C
10. D
11. B
12. 40
13. A
14. 29
15. B
16. D

Drill 1

- C The side length of the square is the radius of the circle, so the area of the circle is $\pi r^2 = 4\pi$. Central angle CDA measures 90 degrees because ABCD is a square. 90 degrees represents $\frac{90}{360} = \frac{1}{4}$ of the circle, so the area of the shaded region will be $\frac{1}{4}$ of the area of the circle, π . The quantities are equal.
- 60 The clock is a circle of 360 degrees, and the 12 numbers create 12 equal intervals around the clock. Therefore, each interval between two consecutive numbers must equal 30 degrees. At 10:00, the two hands are two numbers apart, and create an angle of 60 degrees.
- B The formula for the area of a circle is πr^2 , where r is the radius of the circle. If you set this formula equal to the area of circle C, you get $\pi r^2 = 9\pi$. Dividing by π on both sides of the equation yields $r^2 = 9$, and taking the square root of both sides results in $r = 3$. The radius of circle C is 3, giving you choice (B) for the answer.
- D All diameters in a circle are of equal length. Draw a horizontal diameter in the smallest circle; it must be 2 units long. This diameter is also the radius of the circle with center B, whose diameter must therefore be 4 units long. Draw this diameter horizontally, and you realize that it is also the radius of the circle with center A, whose area is $\pi r^2 = 16\pi$.
- B The circumference of a circle with a diameter of 6 is $\pi d = 6\pi$. The circumference of a circle with a radius of 12 is $2\pi r = 24\pi$, so choice (B) is larger.
- C For this problem, use the circle formulas—Area = πr^2 and Circumference = $2\pi r$ —and do the problem one step at a time. For Quantity A, a circle with a circumference of 4π yields $4\pi = 2\pi r$, so $2r = 4$, and $r = 2$; thus, the area of the circle is $2^2\pi$, or 4π , and 4 times that is 16π . For Quantity B, a circle with an area of 64π yields $64\pi = \pi r^2$, so $r^2 = 64$, and $r = 8$; thus, the circumference of the circle is $2(8)\pi$, or 16π . The quantities are equal.
- 5 First, determine the number of slices that will satisfy the question: There are 20 employees that need at least two slices each, so you need a total of at least 40 slices. Next, determine how many slices each pizza has: Each slice has a central angle of 40° out of 360° , so each pizza has $\frac{360}{40} = 9$ slices. Since 4 pizzas would only provide 36 slices, you need one more pizza, so 5 is the correct response.
- B Each angle in an equilateral triangle measures 60° . The degree measure of the darkened arc is therefore 60° , which represents $\frac{1}{6}$ of the 360° in the circle. Thus, the length of the darkened arc will be $\frac{1}{6}$ of the circumference of the circle. If the diameter is 6, the radius is 3, so the circumference is $2\pi r = 6\pi$. $\frac{1}{6}$ of 6π is π .
- A For Quantity A, the circumference of C is $2\pi r = 2\pi(6) = 12\pi$; the radius is 6. So, the ratio is $\frac{12\pi}{6} = 2\pi$. For Quantity B, half the diameter is the same as the radius, 6. Ballpark that 2π is a little more than 6, making Quantity A greater.
- A Notice that chord AB goes through the center of the circle. Thus, AB is a diameter; a diameter is the longest chord in a circle. Chord CD does not go through the center of the circle, so AB must be longer than CD.
- 864 Draw the diagram of the circle in the square, and draw the radii of length 3 from the center straight up and down. This allows you to see that the side of the square is equal to the diameter of the circle and equals 6. The perimeter of the square equals the sum of all the sides, or 24, and the area of the square equals the side squared, or 36. Use your on-screen calculator to find that the product of the perimeter and the area of the square is 864.
- C, D, and F

Consider all the possible different integer pairs for the dimensions of the rectangle. You cannot try the integer pair of 1 and 9 or 5 and 5, because you know that $x < y$. If the rectangle has sides of 4 and 6, you can solve for the diagonal (equal to the circle's diameter) with the Pythagorean theorem, which gives you $\sqrt{52}$ or $2\sqrt{13}$, correct choice (C). If the rectangle has sides of 3 and 7, the diagonal is $\sqrt{58}$, correct choice (D). If the rectangle has sides of 2 and 8, the diagonal is $\sqrt{68}$, or $2\sqrt{17}$, correct choice (F).

14. C Draw a fourth triangle and semicircle, and you can see that the figure shown represents $1\frac{1}{2}$ circles and $\frac{3}{4}$ of a square. Because three diameters are perpendicular and congruent, they represent three sides of a square; the isosceles right triangles shown constitute three of the four triangles in the completed square. The area of a circle with diameter of 8 (and radius of 4) is $\pi r^2 = 16\pi$. $1\frac{1}{2}$ times this area is 24π . Eliminate choices (A), (D), and (E) because they do not contain 24π . The diameter of each semicircle is the length of the side of the square. The area of the entire square would be $s^2 = 8^2 = 64$. $\frac{3}{4}$ of this area is 48. Adding the two areas together gives you the expression in choice (C).
15. B To find the shaded region, subtract the unshaded region (the triangle and semicircle) from the entire triangle. The area of an equilateral triangle of side x is $\frac{x^2\sqrt{3}}{4} = \frac{8^2\sqrt{3}}{4} = 16\sqrt{3}$. Triangle BCD is also equilateral, and has sides of length 4, so its area is $\frac{4^2\sqrt{3}}{4} = 4\sqrt{3}$. The radius of the circle is 2, so the area of the semicircle is $\left(\frac{1}{2}\right)\pi r^2 = \left(\frac{1}{2}\right)\pi 2^2 = 2\pi$. So the answer is $16\sqrt{3} - 4\sqrt{3} - 2\pi = 12\sqrt{3} - 2\pi$.
16. B Plug in a value for p . If $p = 8$, then the side of the square is 2 and the area is 4. If the circumference of the circle is 8, then the radius is $\frac{4}{\pi}$, and the area is $\frac{16}{\pi}$ —approximately 5. Quantity B is larger. Plug in another value for p and you will find that Quantity B remains larger.
17. C Start by plugging in a radius for the smaller circles; try $r = 2$. The circumference of each circle is $2\pi r = 4\pi$, and the sum of all three circumferences is 12π . Because the diameter of circle O is equal to the sum of the 3 shorter diameters, the diameter of circle O is $4 + 4 + 4 = 12$, its radius is 6, and its circumference is 12π , so the quantities are equal.

1. B For Quantity B, the side of the square is the same length as the diameter of the circle. The diameter is twice the radius, so the radius is 6. Plug this into the formula for area: $A = \pi r^2$ to find that $A = 36\pi$. Quantity B is greater.
2. D The diameter of the circle is 12, so the radius is 6, and the area is 36π . The total number of parts in the ratio is $3 + 4 + 5 = 12$, so each part covers an area of $\frac{36\pi}{12} = 3\pi$. The largest ratio part is 5 times this amount, or 15π .
3. 9π First, draw the circle inside a square. Because the square has an area of 36, each side is 6. This means that the diameter of the circle is 6 and the radius is 3. Using the circle area formula, the answer is 9π .
4. C The four half-cylinders are equivalent to two cylinders of radius 1, whose total volume will therefore be $2(\pi 1^2 6) = 12\pi$. The answer is choice (C).
5. D Draw in either diagonal of the square, which also is the diameter of the circle. You have now created two isosceles right triangles, so the length of the diagonal/diameter is $4\sqrt{2}$, and the radius is $2\sqrt{2}$. The area of the circle is $\pi(2\sqrt{2})^2 = 8\pi$.
6. E Plug in 4 for circle B's diameter; thus circle A's diameter is 32. The radius of A is 2, and the radius of B is 16; circle B has an area of 4π and circle A has an area of 256π . The ratio is $256\pi:4\pi$, which reduces to 64:1.
7. 3.4 First, draw and label the figure. Each of the triangles formed by the origin and the two vertices has legs of $2\sqrt{2}$ and $2\sqrt{2}$. Since each one is an isosceles right triangle—in other words, a 45-45-90 triangle—the sides are in the ratio $x:x$: $x\sqrt{2}$, and the long side of each is $2\sqrt{2} \times \sqrt{2} = 4$. The long side of a triangle is also the side of the square, so the area of the square is 16. Since the side of the square is the same as the diameter of the circle, the diameter is 4, the radius is 2, and the area of the circle is 4π . The area inside the square but outside the circle, then, is $16 - 4\pi$; use an approximation for π to get $16 - (4 \times 3.14) = 3.44$. Rounded to the nearest tenth, the answer is 3.4.
8. B A tangent to a circle forms a right angle with a radius drawn to the point of tangency. If CO is the hypotenuse of $\triangle OBC$, then you know that the legs of the right triangle must be shorter than 5. Since OB is the radius of the circle, you know that the radius of the circle must be less than 5, so the circumference must be less than 10π .
9. C Try plugging in 5 for x . If circle A has an area of 9π , it has a radius of 3. Circle B then has an area of $9\pi \times 5 = 45\pi$. Circle C has an area of $45\pi \times 5 = 225\pi$, with a radius of 15. Therefore, the ratio of circle A's radius of 3 to circle C's radius of 15 is 1:5 or 1: x . Alternatively, note that circle C's area is the area of circle A times x^2 , making the ratio of the areas 1: x^2 . The ratio of the radii should be the square root of this ratio, because area is πr^2 , giving you the ratio 1: x . Both solution methods prove that the quantities are equal.
10. D The diameter of the larger circle, in inches, is 1, so the radius is $\frac{1}{2}$. Therefore, the area of the larger circle is $\pi\left(\frac{1}{2}\right)^2 = \frac{\pi}{4}$, and the area of the smaller circle is half this area, $\frac{\pi}{8}$. Setting this amount equal to the area formula allows you to determine the radius of the smaller circle: $\pi r^2 = \frac{\pi}{8}$; $r = \frac{\sqrt{2}}{4}$. Therefore, the diameter is $\frac{\sqrt{2}}{2}$. Subtract this amount from 1 (the diameter of the larger circle):

$$1 - \frac{\sqrt{2}}{2} = \frac{2 - \sqrt{2}}{2}$$
11. B Plug in a value for the radius of the circle, say $r = 2$, making the diameter 4; \overline{AB} and \overline{CD} are both diameters of the circle, so Quantity A is 8. The circumference of the circle is $4\pi \approx 12$, so Quantity B is greater.
12. 40 Draw and label the figures, and then set up your scratch paper to Plug In. If circle O has a radius of 6, it has an area of $\pi r^2 = 36\pi$; circle M, then, has a radius of 2 and an area of 4π . If sector AOB has an area of 4π out of a total area of 36π , then the sector takes up $\frac{4\pi}{36\pi} = \frac{1}{9}$ of the entire circle, and $\angle AOB$ represents $\frac{1}{9}$ of 360° . The correct answer is thus $\frac{1}{9} \times 360 = 40 \times 360 = 40$.
13. A Note that OD must be a diameter because it is the longest possible line segment crossing the circle. OA and OD (draw it in) are both radii, and therefore equal in length (3), and both of them are equal to AD. Therefore, triangle OAD is equilateral, and the measure of $\angle AOD$ is 60° . The central angle for sector OABC is 120° (the supplement to 60°), making this sector's area $\frac{1}{3}$ the area of the circle:

$\frac{1}{3}3^2\pi = 3\pi$. Because π is slightly greater than 3, 3π is slightly greater than 9, giving you choice (A) for the answer.

14. 29 Draw a rough sketch of the wall, the circles, and the spaces. Notice that there is one space for every circle, plus one more space at the end. The area of each circle is 36π , so $r = 6$, and the diameter of each circle is 12 inches. Convert the length of the wall into inches: $31 \times 12 = 373$ inches, plus the extra 6 inches equals 379 inches. You know that the wall is covered in a certain number of circles plus spaces. Let the distance covered by a circle and a space be represented as $(12 + x)$, and the number of circles be represented as y , so now you have $y(12 + x)$. You also know that there is an extra space, so add an extra x to the end, and this is now the total length of the wall. So, $y(12 + x) + 1 = 379$. The question tells us that x must be an integer, and that you need the greatest number of circles, and thus you want x to be as small as possible. Avoid solving the equation and try plugging in 1 for x , since it's the smallest positive integer. Now the equation becomes $y(12 + 1) + 1 = 379$, and you can solve for y . So, $13y + 1 = 379$ and $13y = 378$, leading to $y = 29$.
15. B To solve this one, Plug In for r and m : Try $r = 2$ and $m = 4$. If $\frac{1}{2}$ of the pizza has been eaten, and the remaining $\frac{1}{2}$ is divided into 4 equal slices, then each of those remaining pieces is $\frac{1}{8}$ of the whole pizza. Now plug in 2 for r and 4 for m in the answer choices; only choice (B) hits your target answer of $\frac{1}{8}$.
16. D The original slice is cut from a pizza with a diameter of 10, and therefore a circumference of 10π . This slice represents $\frac{1.25\pi}{10\pi} = \frac{1}{8}$ of the circumference and therefore $\frac{1}{8}$ of the area, $\frac{25\pi}{8}$ which weighs 4 ounces. A serving weighs 8 ounces, which covers double the area, $\frac{25\pi}{4}$. The area of the six pizzas is $(6)\pi 3^2 = 54\pi$. Dividing this by the area of one serving gives you the total number of servings that the six pizzas represent: $\frac{54\pi}{\left(\frac{25\pi}{4}\right)} = 8\frac{16}{25} = 8.64$. The six pizzas yield 8 servings.

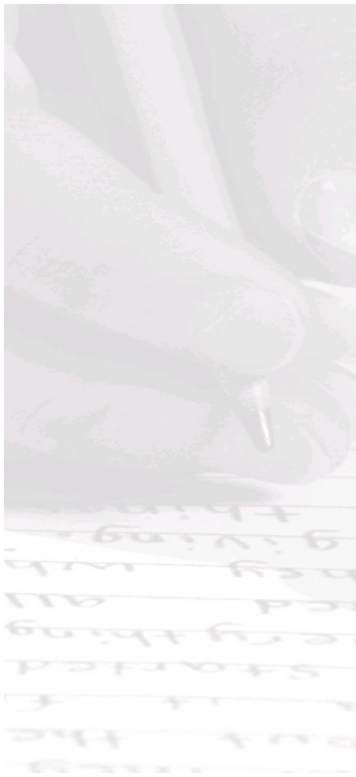

3D Figures

3D FIGURES

Three-dimensional figures on the GRE involve the same fundamental geometry that you will see elsewhere on the test. They just offer ETS new ways to combine the usual circles, triangles, and quadrilaterals. The five-step approach remains the same.

Step 1

Step 1: Draw your shape

In some cases the test will give you a shape, which you may or may not be able to trust, and in others it will give you a word problem and leave it up to you to envision the shape. As with every other part of the test, getting your hand moving is an important first step to entering the problem. Get your shape down on your scratch paper so that you can begin working with it there. On Quantitative Comparison questions involving geometry, instead of Plugging In more than once, you may have to draw your shape more than once.

Step 2

Step 2: Fill in what you know

Whether you are given the shape or not, you will be given a certain amount of information regarding your shape such as the measure of some angles, lengths of some sides, area of some sides, or volume. Put that information in the figure.

Step 3

Step 3: Make deductions

If you are given two angles of a triangle, find the third. If you are given the radius of a circle, find the area. Often this will be the entire problem. Geometry on the GRE is all about finding the missing piece of information. You will be given just enough information to find the piece that is missing.

Step 4

Step 4: Write down relevant formulas

If step three didn't get you the answer, you must still be missing a piece of information. Writing down the formula is a way of both organizing your information and telling you what is missing. When you write your formulas down, fill in the information you have directly underneath the relevant part of the formula. It seems simple, but this way you can't make a mistake. Finding the missing piece of information becomes a simple case of solving for x .

Step 5

Step 5: Drop heights/draw lines

If you're still stuck, you may need to manipulate or subdivide your shapes. If you have triangles, draw in the height. Have you created a 30-60-90? A 45-45-90? Or a Pythagorean triple? Try subdividing the shape or, if it's a three dimensional figure, dashing in the hidden lines.

FORMULAS

There are only three formulas that you need to know for three-dimensional figures. The volume of a rectangular solid is length times width, times height. Remember that it has eight sides should you need to know how to find the surface area. The formula for a right cylinder is easy to remember. Just take the area of the circle and multiply it by the height, pi times radius squared times height. You might occasionally need to know the super Pythagorean theorem, which is $a^2 + b^2 + c^2 = d^2$. This is used to find the diagonal distance between the farthest two vertices of a rectangular solid, but check to see if there is a Pythagorean triple involved before you end up calculating large numbers.

Pythagorean triples show up just as frequently on three-dimensional solids as they do on triangle questions.

For more practice and a more in-depth look at The Princeton Review math techniques, check out our student-friendly guidebook, *Cracking the New GRE*.

DRILL 1
Question 1

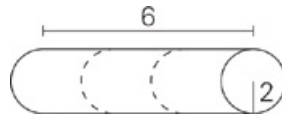

A right circular cylinder with a radius of 2 feet and a length of 6 feet is cut into three equal pieces. What is the volume, in cubic feet, of each of the three pieces?

- 2π
- 3π
- 8π
- 12π
- 24π

Question 2

Quantity A

Three times the total surface area of a cube with edge length of 1 centimeter

Quantity B

The total surface area of a cube with edge length of 3 centimeters

- Quantity A is greater.
- Quantity B is greater.
- The two quantities are equal.
- The relationship cannot be determined from the information given.

Question 3

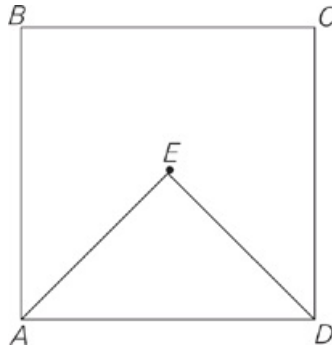

E is the center of square ABCD.

$$AB = 8$$

Quantity A

AE

Quantity B

4

- Quantity A is greater.
- Quantity B is greater.
- The two quantities are equal.

- The relationship cannot be determined from the information given.

Question 4

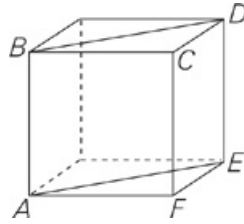

Each edge of the cube shown above has length n . What is the perimeter of quadrilateral ABDE?

- $2n(1 + \sqrt{2})$
- $n\sqrt{2}$
- $4n\sqrt{2}$
- $4n$
- $2n^2$

Question 5

ABCG and CDEF are squares with the same area touching at point C. $\angle BCD$ is a right angle.

Quantity A

3 times the length of AB

Quantity B

The length of AE

- Quantity A is greater.
- Quantity B is greater.
- The two quantities are equal.
- The relationship cannot be determined from the information given.

Question 6

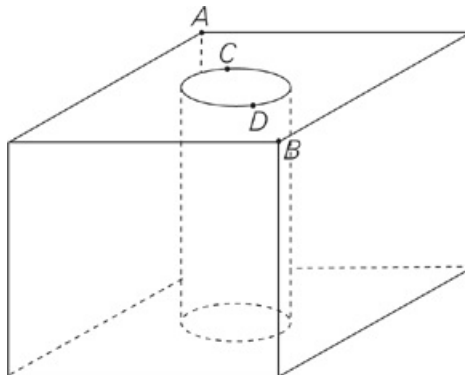

The figure above is a cube with edges of length 9. Points C and D lie on diagonal AB such that points A, C, D, and B are equally spaced. As shown, a right circular cylindrical hole is cut out of the cube so that segment CD is a diameter of the top of the hole. What is the volume of the resulting figure?

- $729 - 162$
- $729 - \frac{81\pi}{2}$

$729 - 9\pi$

729

Question 7

What is the total surface area of a cube with a volume of 512?

384

320

256

152

48

Question 8

The total surface area of a cube is 54.

Quantity A

Quantity B

The length of a diagonal of one face of the cube

3

Quantity A is greater.

Quantity B is greater.

The two quantities are equal.

The relationship cannot be determined from the information given.

Question 9

Cube C has an edge of 4 and cube D has an edge of 5.

Quantity A

Quantity B

The ratio of cube C's total surface area to its volume

The ratio of cube D's total surface area to its volume

Quantity A is greater.

Quantity B is greater.

The two quantities are equal.

The relationship cannot be determined from the information given.

Question 10

A certain building is a rectangular solid with a square base of side length 25m and a volume of $13,000\text{m}^3$. What is the volume, in cubic meters, of a building that has a square base with a side of 75m and the same height as the other building?

1,444.4

4,333.3

39,000

117,000

351,000

Question 11

Marty has a right circular cylindrical pool of diameter 12 feet and his neighbor, Rusty, has a right circular cylindrical pool of diameter 18 feet. If the depths of the pools are equal, then the volume of water in Rusty's pool is how many times that in Marty's pool?

- 1.5
 2.25
 2.5
 4
 4.25

Question 12

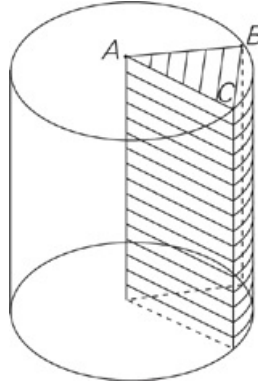

A is the center of the top face of the right circular cylinder in the figure above. If the degree measure of $\angle BAC$ is four times that of $\angle ACB$, and the height of the cylinder is equal to the diameter of its base, then the volume of the shaded region is what fraction of the volume of the entire cylinder?

Question 13

Jack is storing a rectangular box inside a cylindrical container. The container has a volume of 980π cubic inches and a height of 20 inches. Which of the following dimensions could the box have in order to fit inside the cylinder?

Indicate all possible values.

- 3 inches by 6 inches by 12 inches
 6 inches by 9 inches by 15 inches
 10 inches by 10 inches by 10 inches
 8 inches by 9 inches by 16 inches
 11 inches by 15 inches by 18 inches
 9 inches by 9 inches by 20 inches

DRILL 2

Question 1

The Pranger Metal Company makes solid cylindrical steel rods by melting down blocks of steel and pouring the melted steel into molds. Each cylindrical rod has a diameter of 14 inches and a height of 8 inches, and the dimensions of each steel block are 2 feet by 12 feet by 15 feet. If no steel is lost in the production process, how many complete cylinders can be made from a single block of steel?

Question 2

What is the surface area of a right rectangular cylinder with a radius of r and a height that is 1.5 times its diameter?

- $6\pi r^2 + 4\pi r$
- $7\pi r^2$
- $8\pi r^2$
- $3\pi r^3 + 2\pi r^2$
- $3\pi r^3 + 4\pi r$

Question 3

If the volume of a cube equals 64, what is the surface area of the cube?

Question 4

The diagonal of the face of a cube is less than $10\sqrt{2}$ cm. Which of the following could be the volume of the cube? Indicate all possible values.

- 27 cm³
- 64 cm³
- 125 cm³
- 476 cm³
- 729 cm³
- 1,000 cm³

Question 5

To pack her books, Rebekka requires a cube-shaped box with a volume of at least 2 cubic feet. Which of the following amounts could be the length of the edge of her box, in feet? Indicate all possible values.

- 1.1
- 1.2
- 1.3
- 1.4
- 1.5

Emily must ship a cylinder-shaped gift with a height of 11 inches and a volume of 176π cubic inches. What is the volume, in cubic inches, of the smallest rectangular box which can contain this cylinder?



Question 7

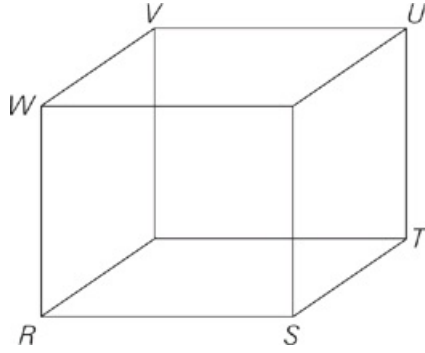

In the rectangular solid above, $RS = ST = TU = 7.5$. Which of the following is true?

- The surface area of the rectangular solid is 421.875
- The volume of the rectangular solid is 337.5
- WT (not shown) = UT
- The distance from V to S is 12.99

Question 8

A rectangular shipping container has dimensions of 23 feet by 29 feet by 37 feet. What is the longest distance between any two corners of the container, rounded to the nearest foot?

- 41
- 43
- 44
- 47
- 52

Question 9

What is the surface area, in square inches, of a box that measures 29 inches by 37 inches by 47 inches?



Question 10

If the volume of a cube is 125, then the total area of 2 of its faces is

- 20
- 25
- 40
- 50
- 75

Question 11

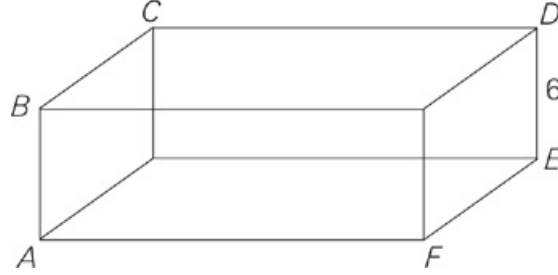

The volume of the rectangular solid above is 720. If $AF = 15$, which of the following is closest to the distance from C to F?

- 6
- 8
- 12
- 15
- 18

Question 12

A cylindrical object has a volume of 332.75π cubic inches, and its height is equal to its diameter. What is the radius of the object?

Question 13

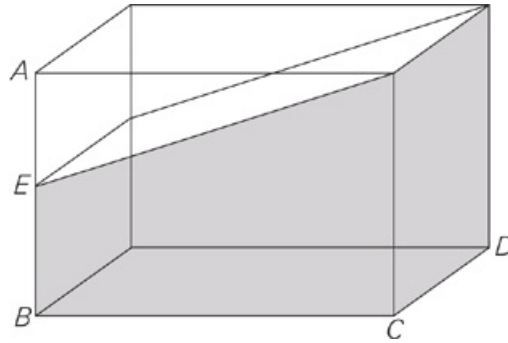

In the rectangular solid depicted above, $AB = 6$, $BC = 8$, $CD = 5$, and $AE > EB > 2$. Which of the following could be possible values for the volume of the shaded area?

- 60
- 70
- 150
- 170
- 180
- 240

ANSWERS

Drill 1

1. C
2. B
3. A
4. A
5. A
6. B
7. A
8. A
9. A
10. D
11. B
12. $\frac{1}{3}$
13. A, B, D, F

Drill 2

1. 505
2. C
3. 84
4. A, B, C, D, E
5. A, B
6. 704
7. D
8. E
9. 4,175
10. D
11. E
12. 5.5
13. D

Drill 1

- C The answer asks for $\frac{1}{3}$ of the whole volume, so begin by dividing the height of the trunk by 3 to find the volume of one of the sections of the trunk: $\frac{6 \text{ ft}}{3} = 2 \text{ ft}$. The volume formula for a cylinder is: $V = \pi r^2 h = \pi \times 2^2 \times 2 = 8\pi$.
- B Three times the surface area of a cube with edge length of 1 cm is three times the area of each square face times the number of faces: $3 \times (1 \text{ cm} \times 1 \text{ cm}) \times 6 \text{ faces} = 18 \text{ cm}^2$. The surface area of a cube with edge length of 3 cm is $(3 \text{ cm} \times 3 \text{ cm}) \times 6 \text{ faces} = 54 \text{ cm}^2$. Quantity B is greater.
- A The diagonal of a square is always longer than its side, so half a diagonal—segment AE—must be longer than half a side. Half the length of a side of this square is 4. Therefore, AE is larger than 4.
- A Plug in a value for n: Try $n = 3$. If each edge of the cube is 3, $AB = DE = 3$, and because the diagonal of a square forms two 45-45-90 triangles, $BD = AE = 3\sqrt{2}$. The total perimeter is $3 + 3 + 3\sqrt{2} + 3\sqrt{2} = 6 + 6\sqrt{2}$. Now plug in 3 for n in the answer choices; only choice (A) hits your target.
- A Draw it! You should end up with two squares oriented the same way touching at C. The squares have the same area, so their sides must be the same length. Plug in a side length for the squares to simplify the comparison—try 2. A square cut in half along its diagonal yields a pair of 45-45-90 triangles, so these two squares with sides of 2 each have diagonals of $2\sqrt{2}$. Diagonals AC and CE connect to form segment AE. Quantity A is $3 \times 2 = 6$, and Quantity B is $2\sqrt{2} + 2\sqrt{2} = 4\sqrt{2}$. Quantity A is greater.
- B You will be subtracting the volume of the cylinder from that of the cube, so the answer will contain π ; eliminate choices (A) and (E). To find the volume of the figure, start with the volume of the cube: $V = s^3 = 9^3 = 729$. The formula for volume of a cylinder is $V = \pi r^2 h$. The cylinder runs the length of the cube, so its height is the same as the length of the cube's edge, 9. Next, find the radius. The length of diagonal AB is $9\sqrt{2}$ (remember your special triangles—this is a 45-45-90 triangle!). The points between A and B are equally spaced, so the length of CD, the circle's diameter, is $\frac{1}{3}$ the length of AB, $3\sqrt{2}$. The radius is $\frac{1}{2}$ the diameter, or $\frac{3\sqrt{2}}{2}$. Plug the radius and the height into the formula: $V = \pi r^2 h = \pi \left(\frac{3\sqrt{2}}{2}\right)^2 (9) = \frac{81\pi}{2}$. Subtract this from the cube's volume for a final answer of $729 - \frac{81\pi}{2}$.
- A First, write out your formulas and draw a figure. The volume of a cube is $V = s^3 = 512$, giving you $s = 8$. The surface area of a cube is 6 times the area of each square face of the cube ($SA = 6s^2$), therefore, $6 \times 8^2 = 384$.
- A The surface area of a cube is 6 times the area of each square face of the cube ($SA = 6s^2$), or $54 = 6s^2$. So each side is 3. The diagonal of the square forms the hypotenuse of a right triangle. Remember that the hypotenuse of a right triangle is always longer than either leg. Therefore, the diagonal is larger than 3.
- A A cube has 6 identical faces, each with an area of s^2 , so the surface area of a cube is $6s^2$; the volume of a cube is s^3 . Quantity A is $\frac{6 \times 4^2}{4^3} = \frac{6}{4}$, and Quantity B is $\frac{6 \times 5^2}{5^3} = \frac{6}{5}$. Quantity A is greater.
- D First, eliminate choices (A) and (B) because the volume must increase when the side of the square base increases. Next, set up a proportion using the square base of the prism: $\frac{13,000}{25^2} = \frac{x}{75^2}$. Finally, cross-multiply and solve for x to get choice (D).
- B Try plugging in a value for the depth, 2 feet. Note that the radii are half the given diameters. Therefore, the volume of water held by Marty's pool is $V = \pi r^2 h = \pi(6)^2(2) = 72\pi$ and the volume of water held by Rusty's pool is $V = \pi r^2 h = \pi(9)^2(2) = 162\pi$. Dividing 162π by 72π yields 2.25.
- $\frac{1}{3}$ First, find the angle measures. Since AC and AB are radii of the circle, the triangle they form along with BC must be isosceles. Let the small angles, $\angle ACB$ and $\angle ABC$, be x, which makes $\angle BAC$ equal to $4x$; now $4x + x + x = 180$, so $x = 30$ and $\angle BAC$ must be 120° .

unnecessary. Since $\angle BAC$ represents $\frac{120}{360}$, or $\frac{1}{3}$, of the circular base, the shaded represents the same fraction of the entire circle. 

13. A, B, D, and F

First, find the dimensions of the cylinder. Because the cylinder's height is 20 and its volume is 980π , and $V = \pi r^2 h$, $980\pi = \pi (r^2)(20)$, and $r = 7$. The diameter of the cylinder is 14. Because the end of the cylinder is a circle with a diameter of 14, the largest box that could fit in the cylinder would have a square base with a diagonal of 14. Using the Pythagorean theorem, you can find that the length and the width of the largest possible box equal 14 divided by $\sqrt{2}$, or approximately 9.90. Therefore, the box's length and width must each be less than 10, and its height may be up to 20. Choices (A), (B), (D), and (F) match these criteria and work as the dimensions of the box.

1. 505 To find the number of cylinders that can be made from one block of steel, divide the volume of the block by the volume of a cylinder. Start by converting the dimensions of the block into inches: Each steel block is 24 inches by 144 inches by 180 inches, so the volume is $24 \times 144 \times 180 = 622,080$. The formula for the volume of a cylinder is $V = \pi r^2 h$, so the volume of each cylinder is $\pi \times 7^2 \times 8 = 1230.88$. Finally, $622,080 \div 1230.88 = 505.395$; the problem asked for complete cylinders, so the correct answer is 505.
2. C It's a geometry problem with variables in the answer choices, so draw the figure and set up your scratch paper to Plug In. Plug in an easy number like $r = 5$; label the radius 5 and the height 15, which is 1.5 times your diameter of 10. The surface area of a cylinder is made up of 3 smaller areas: 2 identical circular bases on top and bottom, and a rectangle that's the height of the cylinder on one side and the circumference of the base on the other. If $r = 5$, then the area of each base is 25π , or 50π for the 2 of them. The rectangle is $15 \times 10\pi = 150\pi$, so the total surface area is 200π , your target answer. Plug 5 in for r in the answers, and only choice (C) matches your target answer of 200π .
3. 84 Use the formula for the volume of a cube to find the length of each side: $V = s^3$, so $64 = s^3$, and $s = 4$. To find the surface area of a cube, find the area of each face of the cube and multiply by 6: Each side is 4, so each face has an area of $4 \times 4 = 16$, and the total surface area of the cube is $16 \times 6 = 84$.
4. A, B, C, D, and E
If the diagonal were exactly $10\sqrt{2}$, then the side of the cube would be 10. Because the diagonal is less than $10\sqrt{2}$, each side is less than 10. Therefore, the volume must be less than 10^3 , or 1,000. Any value less than 1,000 is correct.
5. A and B Plug in the answers to your on-screen calculator. When cubed, choices (A) and (B) are less than 2 cubic feet. The other three choices for the edge of the box produce volumes over 2 cubic feet.
6. 704 Because the cylinder's height is 11 and its volume is 176π , and $V = \pi r^2 h$, $176\pi = \pi(r^2)(11)$, and $r = 4$. The diameter of the cylinder is 8. The box will need a length of 8 and a width of 8 to accommodate the base of the cylinder, and a height of 11. The volume of the smallest box will equal $8 \times 8 \times 11$, or 704.
7. D Because all the edges are equal, the figure is a cube. The formula for the surface area of a cube is $6s^2$, where s is a side of the cube. Thus, the surface area of the solid is 337.5; eliminate choice (A). The formula for the volume of a cube is s^3 , so the volume of the cube is 421.875; eliminate choice (B). WT is a diagonal of the cube. The formula for the diagonal of a box is $a^2 + b^2 + c^2 = d^2$, where a , b , and c are the sides of the box and d is the diagonal. Thus, WT is 12.99 and does not equal UT . Eliminate choice (C). VS is also a diagonal of the cube, so its length is 12.99. The only correct answer is choice (D).
8. E Draw a rectangular box. The longest distance between any two corners is going to be the box's three-dimensional diagonal from a bottom corner to the top corner furthest away. You can solve this problem by using the Super Pythagorean theorem $a^2 + b^2 + c^2 = d^2$. $23^2 + 29^2 + 37^2 = 2,739 = d^2$. The square root is a little more than 52.
9. 4,175 Calculate the surface area of each side of the box. Two sides are each: $29 \times 37 \times 2 = 1,073$ square inches. Two other sides are $29 \times 47 \times 2 = 1,363$ square inches. The last two sides are $37 \times 47 \times 2 = 1,739$ square inches. The sum of the six sides is 4,175.
10. D The volume formula for a cube is $V = s^3$, so a volume of 125 yields a side of 5. One face therefore has an area of 25, and the total area of 2 faces is 50. If you selected choice (C), you may have found the perimeter rather than the area. If you selected choice (B), you may have forgotten to find the total for 2 faces, and if you selected choice (A), you may have done both.
11. E The distance from C to F is the diagonal of the box, so use the Super Pythagorean theorem: $a^2 + b^2 + c^2 = d^2$, where a , b , and c are the sides of the box and d is the diagonal. You have the length and height of the box, so use the volume formula to find the width: $720 = (15)(6)w$, so the width is 8. Now plug your numbers into the formula: $15^2 + 8^2 + 6^2 = d^2$, so $325 = d^2$, and $d = 18.03$.
12. 5.5 The volume of a cylinder = $\pi r^2 h$. Since the height equals the diameter: $332.75\pi = \pi(r^2)(2r)$. Solving for r gives you 5.5 as the final answer
13. D First, find the volume of the entire box, which equals $6 \times 8 \times 5 = 240$. Solve for the volume of the three-dimensional triangular shape on top and subtract it from the total volume to find the volume of the shaded part. The triangular shape has known dimensions of 8 by 5. The third dimension ranges based on the length of AE , with $3 < AE < 4$ because AE has to be bigger than EB . Therefore, the triangular shape's volume falls between one-half of $8 \times 5 \times 3 = 60$ and one-half of $8 \times 5 \times 4 = 80$. The shaded area's volume falls between $240 - 80 = 160$ and $240 - 60 = 180$. Only choice (D) works.

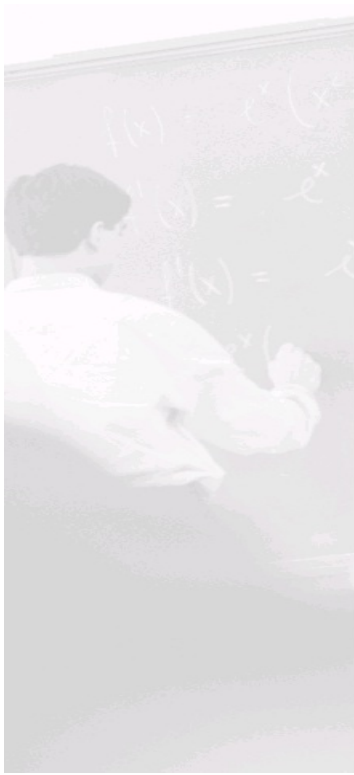

Charts and Graphs

CHARTS AND GRAPHS

The first step on a Charts and Graphs question is to get familiar with the data. You will often be given two or occasionally even three charts full of information. Just like in a Reading Comprehension question, you may have to scroll down to get to the second chart. Make sure that you always scroll down to see if there is a second chart. The questions would be pretty confusing if you missed a whole chart.

Pay careful attention to footnotes, parentheses, and small print. They almost always include information you will need to read the chart or to answer a question. Take note of the units as well. You won't need them when you calculate, but you will almost certainly see wrong answer choices that provide the right numbers with the wrong decimal points. If the chart gives you information in thousands or in millions make sure to count your zeros.

THE MATH

The math involved in chart questions is pretty fundamental. Typically it involves fractions, percentages, addition, multiplication, and subtraction. The addition, subtraction, and multiplication will be made more difficult by including large numbers with lots of zeros (information given in thousands, etc.), answer choices expressed in scientific notation, or information taken from multiple charts.

Ballpark Before You Calculate

Remember that the answer choices are part of the question. As you go through these drills, note the range in numbers given in your answer choices. The highest answer choices could be double or even five times the size of the smallest answer choice. These questions are ripe for Ballparking. In fact, they are even designed for it. While you will have to do more actual calculating on charts questions than anywhere else on the test, you should never have to calculate all five answer choices; in fact, rarely will you have to calculate more than two. When ETS asks you to find approximately some piece of information, what they're really saying is, "It's okay to Ballpark." If there is a large value range in the answer choices, you should be able to eliminate at least two if not three answer choices by Ballparking, leaving you with only two close answer choices to calculate.

Percent Change

There is one formula to keep in mind for Chart questions. That is the percentage change formula. If a question asks you to find the percentage increase, or percentage decrease, the formula is $\text{difference/original} \times 100$. For example, a question may give you the sales figures for company X for the years 1972 through 1986. The question may then ask you which period had the greatest percentage increase in sales. The answer choices will say 1979 to 1980, 1982 to 1983, etc. At least one answer choice will have a percentage decrease. You can eliminate that. One or two others will have very small increases, so you can eliminate those. The remaining answer choices may have the exact, or very close, numerical increases, but differing totals. You should realize that the same numerical increase on a smaller total will yield a greater percentage increase (if you increase the total by one, from five to six, that is a 20 percent increase, but if you increase the total by one from ten to eleven, that is only a 10 percent increase). If you have to calculate, use the percentage change formula. If the sales total in 1982 was 5.4 million and the sales total in 1983 was 6.8 million, then the difference was 1.4 million. Divide that by the original of 5.4 million and you get approximately .26. Multiply this by one hundred and you're left with a percentage increase of 26 percent. If you don't want to do the long division, reduce your fraction to $\pm \frac{1}{4}$ and look for answer choices about 25 percent.

SCRATCH PAPER

As always, scratch paper is key. Label everything. Not only will you be dealing with multiple pieces of information, but you may be able to use information you found for one question on another question based upon the same chart. Because you will be doing some calculating, that scratch paper can get messy and confusing. Block out some clean space to do your work and label every number you put down. This becomes especially important if you need to check your units. Wrong answers on Charts problems can often be directly traced to sloppy scratch paper and unlabeled information. Don't be messy.

For more practice and a more in-depth look at The Princeton Review math techniques, check out our student-friendly guidebook, *Cracking the New GRE*.

DRILL 1

Questions 1-3 refer to the following data.

NEW AND REFURBISHED YACHT SALES OF COMPANY J, 1994 TO 2004 AND MEDIAN SALE PRICE FOR SELECTED YEARS

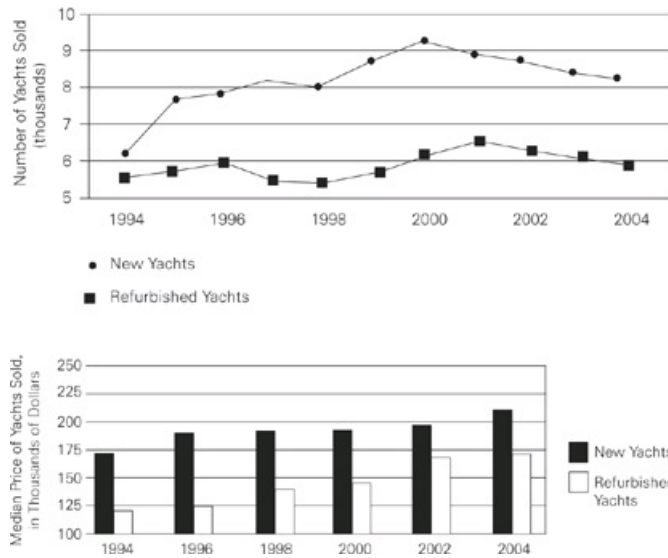

Question 1

According to the graph, which of the following could be the number of refurbished yachts sold in 1996?

- 7,750
- 5,900
- 5,590
- 5,400
- 5,390

Question 2

In which of the following years did Company J sell more refurbished yachts than in the previous year, but fewer new yachts than in the previous year?

- 1995
- 1997
- 1999
- 2001
- 2003

Question 3

In the year when the median price of new yachts sold by Company J was closest to the median price of refurbished yachts sold by Company J, how many thousand refurbished yachts did the company sell?

- 6.3
- 6.7

8.3

8.7

TOTAL BUDGET FOR THE CITY OF SPRINGFIELD
1992 AND 1998

INCOME SOURCES (IN THOUSANDS OF DOLLARS)

EXPENDITURES (IN THOUSANDS OF DOLLARS)

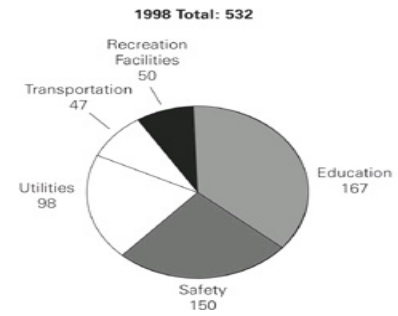
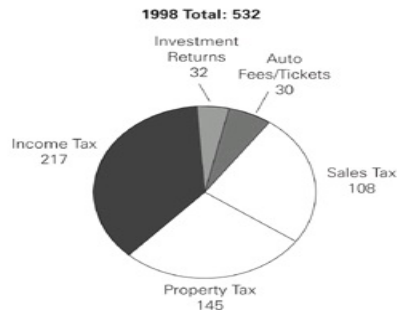
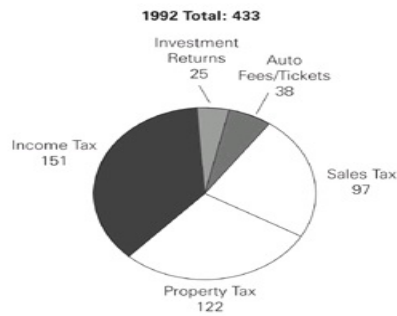

(Click [here](#) to view a larger image.)

Question 4

In 1998, the amount that the city of Springfield spent on safety was how many times the amount the city spent on recreation facilities?

- $2\frac{1}{4}$
- $2\frac{2}{5}$
- 3
- $3\frac{1}{4}$
- $3\frac{1}{2}$

Question 5

In 1992, approximately what percent of Springfield's income came from income tax?

- 50%
- 45%
- 40%
- 35%
- 30%

Question 6

What was the approximate percent increase in Springfield's total income from 1992 to 1998?

- 19%

- 23%
 - 36%
 - 42%
 - 48%
-

**AIRLINE DEPARTURES BY COUNTRY
IN 1990 AND 2001**

Country	1990 (percent)	2001 (percent)
United States	24.2	31.1
United Kingdom	10.8	9.5
France	9.1	5.0
Germany	5.5	6.2
Japan	4.3	3.1
Brazil	3.1	4.0
China	2.0	7.7
Spain	1.2	0.3
Australia	0.8	0.6
All Others	39.0	32.5
Total Number of Departures	12,050,205	18,205,301

Question 7

By approximately what percent did the total number of departures increase from 1990 to 2001?

- 33%
- 50%
- 66%
- 133%
- 150%

Question 8

If the nine individually listed countries (excluding those characterized as “All Others”) are ranked from highest to lowest by number of departures in 1990, how many countries ranked lower in 2001 than in 1990?

Questions 9-12 refer to the following data.

HAPPY PUPPY PET DEPOT SALES
BY PERCENT OF TOTAL ANNUAL SALES

■ 100% sales in 2002 = 10,000 animals
□ 100% sales in 2003 = 9,000 animals

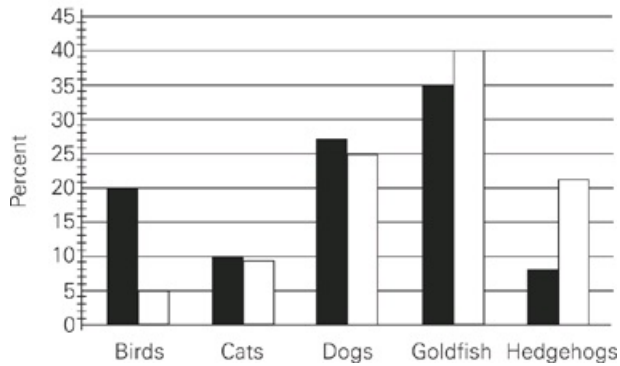

Question 9

In 2003, how many categories of animals individually accounted for more than 20% of the depot's annual sales?

Question 10

From 2002 to 2003, what was the increase in the total number of goldfish sold?

- 5
- 70
- 225
- 850
- 1,380

Question 11

By approximately what percent did total cat sales change from 2002 to 2003?

- 0%
- 1%
- 2%
- 5%
- 9%

Question 12

The total sales at Happy Puppy Pet Depot is calculated by adding the sales from Store A to those from Store B. Both stores sold an equal number of pets in 2002. If the sales of pets in Store A increased by 34% in 2003, by approximately what percent did sales decrease in Store B during the same year?

- 12%
- 34%
- 42%

- 66%
 - 97%
-

Questions 13-15 refer to the following data.

MEMBERSHIP OF THE NORTH COUNTY AUTO
MECHANICS AND AUTO SALES ASSOCIATIONS
IN 1998

Auto Mechanics Association		Auto Sales Association
	Gender	
345	Male	500
464	Female	400
809	Total	900
	Age	
23	Youngest	25
68	Oldest	72
34	Average	44
	Number of Children	
125	0	209
223	1	126
204	2	98
117	3	85
54	4	132
52	5	128
34	6 or more	122
	Highest Education Level	
129	Some High School	185
266	High School Graduate	419
307	College Graduate	202
87	Advanced Degrees	94

(Click [here](#) to view a larger image.)

Question 13

If 50 of the male members of the Auto Sales Association were replaced by 50 female members, what would be the ratio of male to female members in the Auto Sales Association?

- 1 to 1
- 1 to 2
- 1 to 3
- 2 to 1
- 3 to 1

Question 14

If 92 members of the Auto Sales Association were females with 5 children, how many members of the Auto Sales Association were males who did not have 5 children?

Question 15

If all the members of the Auto Mechanics Association who held advanced degrees and all the members of the Auto Mechanics Association who had at least 5 children voted for a measure, how many more votes were needed to gain a majority?

- 173
- 344
- 556
- 636
- It cannot be determined from the information given.

DRILL 2

Questions 1-3 refer to the following data.

NUMBER OF BOOKS SOLD BY BOOK STORE X IN 2005 LISTED BY MAJOR CATEGORY AND TARGET AUDIENCE

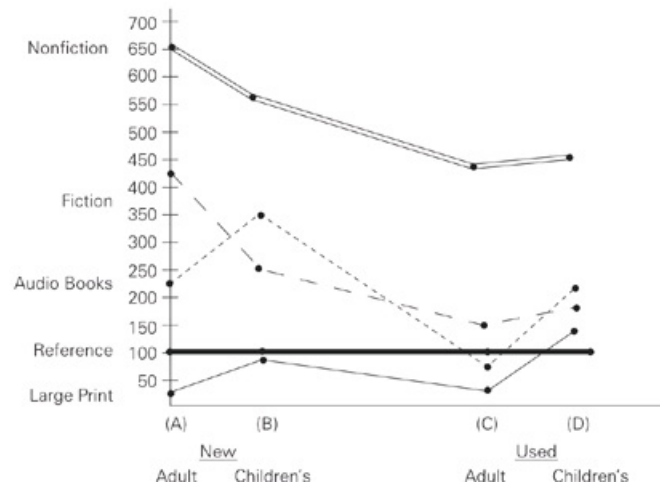

	New Adult (A)	New Children's (B)	Used Adult (C)	Used Children's (D)
Nonfiction	650	540	380	420
Fiction	430	250	120	170
Audio Books	220	330	50	200
Reference	100	120	90	80
Large Print	20	90	10	140

NUMBER OF NONFICTION BOOKS SOLD BY BOOK STORE X IN 2005

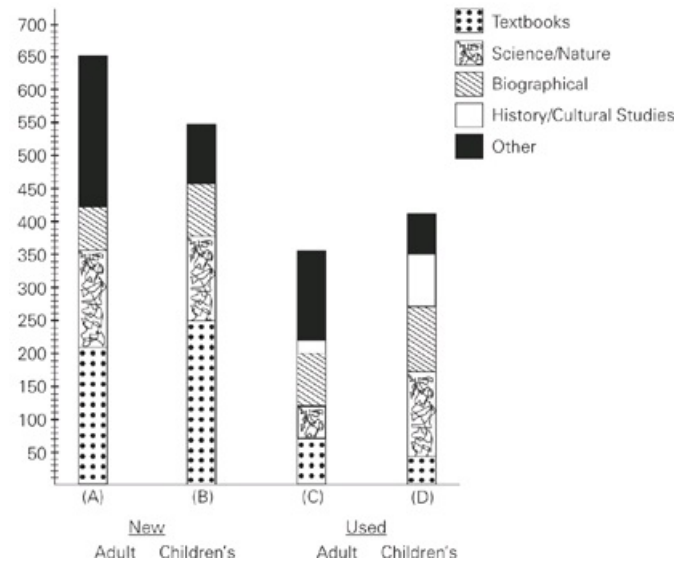

	New Adult (A)	New Children's (B)	Used Adult (C)	Used Children's (D)
Textbooks	210	240	80	40
Science/Nature	150	120	70	120
Biographical	60	80	30	90
History/Cultural Studies	50	90	20	70
Other	180	10	180	100

Question 1

For which major category of books was the number sold most nearly the same for each of the four groups?

- Nonfiction
- Fiction
- Audio Books
- Reference
- Large Print

Question 2

Approximately how many Used Adult Science/Nature books did Book Store X sell in 2005?

- 70
- 90
- 110
- 150
- 180

Question 3

Which of the following correctly lists the number of audio books sold for each of the four groups from greatest to least?

- B, D, A, C
 - B, A, D, C
 - A, D, B, C
 - A, C, B, D
 - D, A, C, B
-

INCOME AND EXPENDITURES AT UNIVERSITY F IN 2004

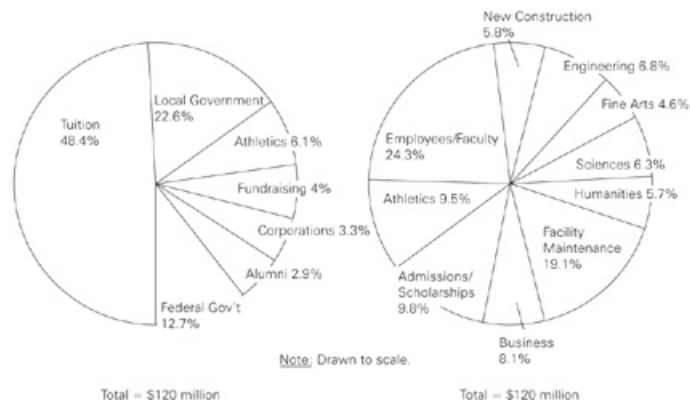

(Click [here](#) to view a larger image.)

Question 4

University F's expenditures in which of the following categories were most nearly equal to \$5.4 million in 2004?

- Fine Arts
- Facility Maintenance
- Humanities
- Athletics
- Business

Question 5

In 2004, $\frac{1}{2}$ of University F's new construction expenditures, $\frac{1}{4}$ of its facility maintenance expenditures, and $\frac{3}{5}$ of both the athletics and admissions/scholarships expenditures went towards the construction of a new gymnasium. Approximately how many millions of dollars did University F spend on the new gymnasium in 2004?

- \$13 million
- \$18 million
- \$20 million
- \$24 million
- \$30 million

Question 6

At University F in 2004, what was the closest approximation to the percentage of athletics expenditures NOT covered by athletics income?

- 32%
- 36%
- 42%
- 56%
- 64%

AVERAGE TEMPERATURE HIGHS AND LOWS FOR CITY X

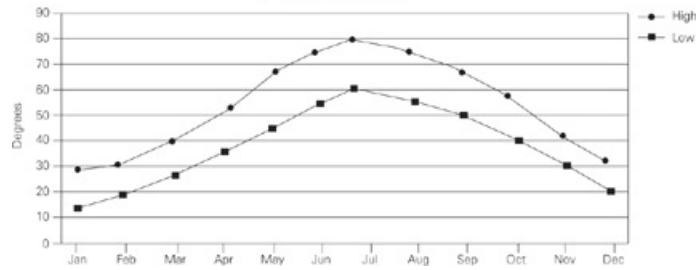

AVERAGE MONTHLY RAINFALL FOR CITIES X AND Y

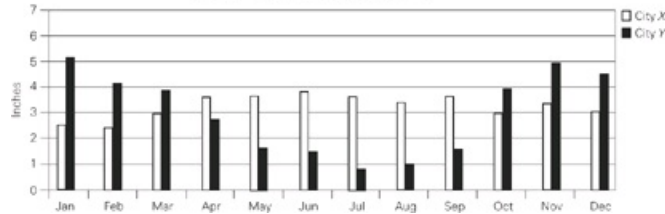

Question 7

During how many of the months in which City Y's average rainfall exceeded 3 inches was City X's average low temperature greater than or equal to 30 degrees?

- One
- Two
- Three
- Four
- All

Question 8

The "monthly midpoint" is calculated by taking the average (arithmetic mean) of a month's average high and low. Which of the following is the average monthly midpoint in City X for the 3-month period from July to September?

- 55.3
- 60.0
- 64.7
- 69.3
- 74.0

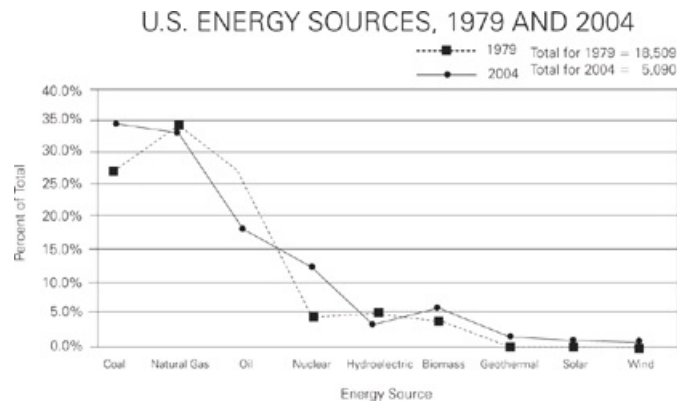

(Click [here](#) to view a larger image.)

Question 9

What is the approximate ratio of energy used from oil in 1979 to energy used from oil in 2004 ?

- $\frac{55}{1}$
- $\frac{35}{1}$
- $\frac{11}{7}$
- $\frac{25}{18}$
- $\frac{9}{10}$

Question 10

Which of the following can be inferred from the graphs?

Indicate all possible values.

- The number of power plants constructed in the U.S. between 1979 and 2004.
- The percent of total energy used from oil, coal, and natural gas sources was greater in 2004 than the percent of total energy used from the same sources in 1979.
- The amount of energy used from hydroelectric sources in 2004 was less than one fourth the amount of energy used from hydroelectric sources in 1979.

PRODUCTION OF GOLF EQUIPMENT AND SUPPLIES
 WORLD PRODUCTION 1994-1998
 (values are in millions of dollars)

Country	1994		1995		1996		1997		1998	
	Value	Percent of Total	Value	Percent of Total	Value	Percent of Total	Value	Percent of Total	Value	Percent of Total
United States	2,691	62.3	2,975	63.7	3,248	65.1	3,424	65.1	3,438	63.2
Japan	678	15.7	752	16.1	793	15.9	831	15.8	876	16.1
South Korea	376	8.7	383	8.2	384	7.7	426	8.1	457	8.4
Germany	177	4.1	159	3.4	180	3.6	179	3.4	201	3.7
Great Britain	125	2.9	140	3.0	135	2.7	153	2.9	169	3.1
Canada	125	2.9	103	2.2	105	2.1	100	1.9	125	2.3
Argentina	99	2.3	103	2.2	95	1.9	100	1.9	114	2.1
Other Countries	49	1.1	55	1.2	50	1.0	47	0.9	60	1.1
Total	4,320	100	4,670	100	4,990	100	5,260	100	5,440	100

UNITED STATES PRODUCTION

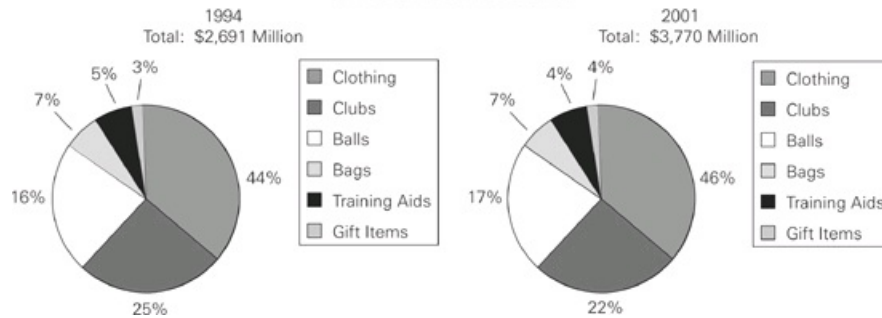

(Click [here](#) to view a larger image.)

Question 11

In 1994, the value of clubs produced in the United States was approximately what percent of the value of golf equipment and supplies produced in the world?

- 33%
- 25%
- 16%
- 13%
- 9%

Question 12

In 1994, the total production for golf equipment and supplies from which country was nearest in value to the combined production of balls, bags, and gift items in the United States in the same year?

- Japan
- North Korea
- Germany
- Great Britain
- Canada

Question 13

From 1996 to 1998, the value of golf equipment and supplies produced by South Korea increased by approximately what percent?

- 1%
 - 7%
 - 16%
 - 19%
 - 27%
-

HONEY PRODUCTION IN REGION Z:
1980 TO 1986

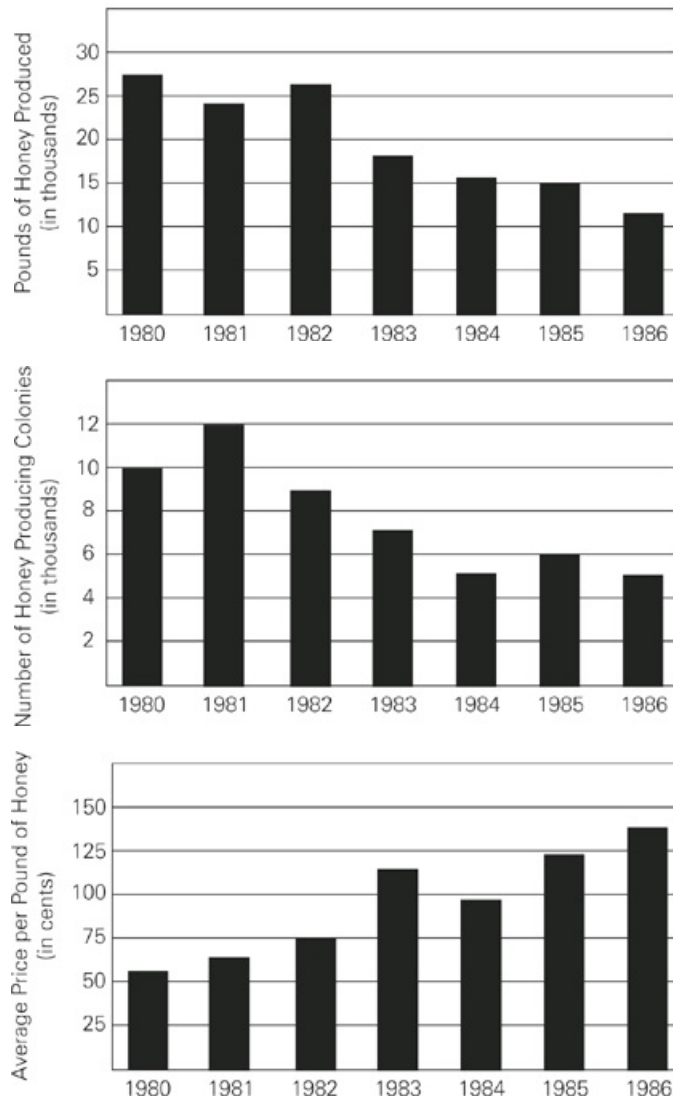

Question 14

What was the approximate value, in dollars, of the honey produced in Region Z in 1985?

- 19,000
- 15,000
- 6,000
- 580
- 124

Question 15

By approximately what percentage did the number of colonies in Region Z decrease from the year with the highest number to that with the lowest number?

- 140%
- 60%
- 40%
- 30%

DRILL 3

Questions 1-3 refer to the following data.

2002 AIRPLANE INVENTORY FOR AIRLINES A AND B
BY YEAR OF PURCHASE
(as a percent of the 2002 inventory)

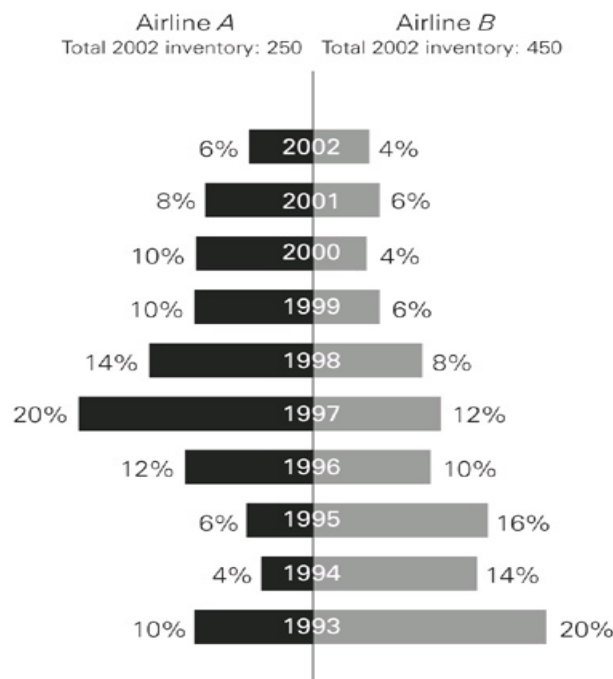

Question 1

What was the total number of inventoried airplanes purchased by both airlines from 1997 to 1999?

- 110
- 117
- 175
- 227
- 315

Question 2

In 1994, Airline A bought 25 airplanes. All of these airplanes either remained in Airline A's inventory or were sold to another airline. What percent of these airplanes were sold to another airline?

- 4%
- 10%
- 40%
- 60%
- 90%

Question 3

Which of the following can be inferred from the graph?
Indicate all possible values.

- Airline A had fewer customers than Airline B over the period shown.

The 2002 Airline B's inventory of planes purchased in 1993 was twice that purchased by Airline A in the same year.

If all airplanes were purchased new, then the median age of an airplane in Airline B's inventory in 2002 was greater than that of an airplane in Airline A's inventory in 2002.

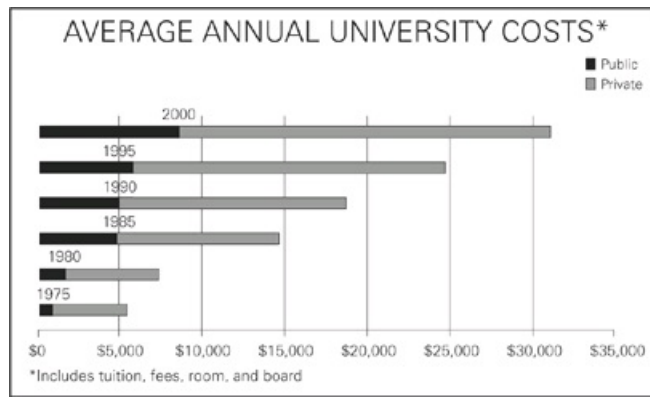

Question 4

In 2005, the ratio of the average annual cost to attend a private university to the average annual cost to attend a public university was the same as it was in 1990. If the average annual cost to attend a public university in 2005 was \$11,000, what was the average annual cost to attend private university in that year, to the nearest \$1,000?

- \$18,000
- \$24,000
- \$29,000
- \$32,000
- \$34,000

Question 5

By approximately what percent did the average annual cost to attend a private university increase from 1980 to 2000?

- 27%
- 73%
- 138%
- 267%
- 367%

Question 6

The average annual cost to attend a private university increased at a constant rate from 1995 to 2000, and 2.5 million students attended private universities in 1998. If 2 million students attended private universities in 1990, then by approximately what percent did the total dollar amount spent on private universities increase from 1990 to 1998?

- 25%
- 30%
- 55%
- 70%
- 90%

Questions 7-8 refer to the following data.
The following charts represent April 2008 plant sales at the Friendly Nursery.

The following charts represent April 2008 plant sales at the Friendly Nursery.

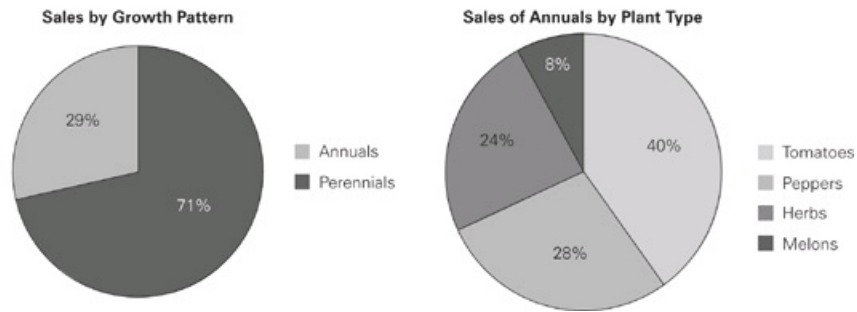

(Click [here](#) to view a larger image.)

Question 7

Which of the following is most nearly the percent of plants sold at Friendly Nursery in April 2008 that were herbs?

- 70%
- 40%
- 24%
- 18%
- 8%

Question 8

In April 2008 there were four varieties of tomatoes available at Friendly Nursery: Red Giants, Mortgage Lifters, Beefsteaks and Sun Golds. If 1000 plants were sold, which of the following could be the number of Beefsteak tomato plants sold?

Indicate all possible values.

- 1
- 42
- 246
- 312
- 580

HAPPY PUPPY PET DEPOT SALES
BY PERCENT OF TOTAL ANNUAL SALES

■ 100% sales in 2002 = 10,000 animals
□ 100% sales in 2003 = 9,000 animals

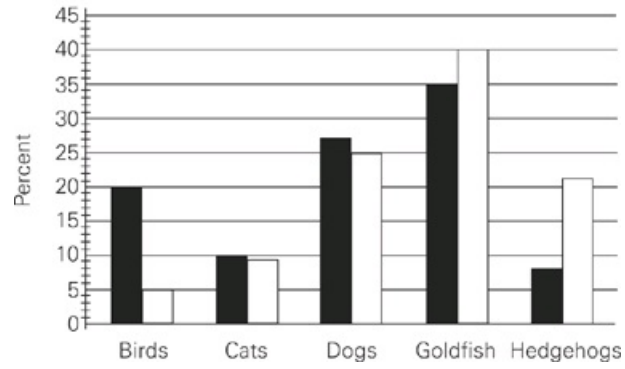

Question 9

If Happy Puppy Pet Depot saw the same percentage increase in total number of animals sold from 2003 to 2004 as it did from 2002 to 2003, how many animals, to the nearest integer, did the store sell in 2004?

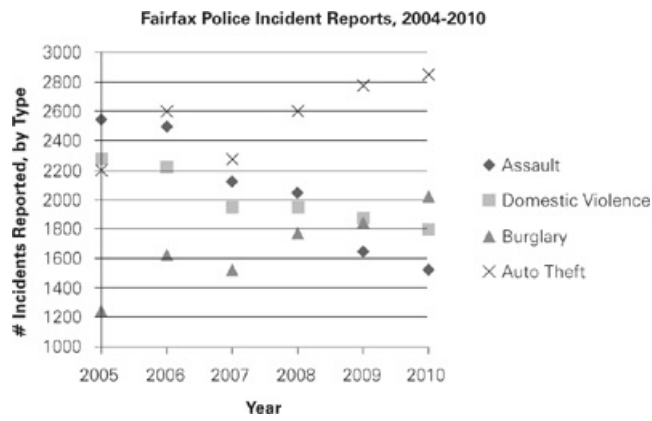

Question 10

For how many of the years shown in the graph was the number of nonviolent crimes (burglary and auto theft) greater than the number of violent crimes (assault and domestic violence)?

- None
- One
- Two
- Three
- Four

AVERAGE TEMPERATURE HIGHS AND LOWS FOR CITY X

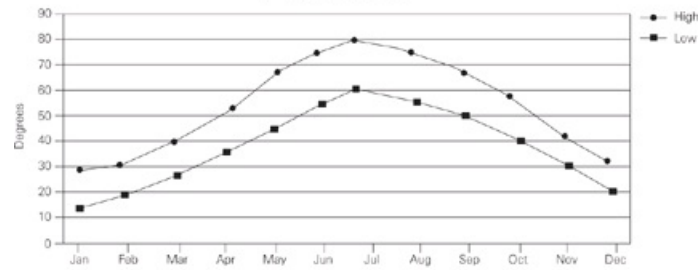

AVERAGE MONTHLY RAINFALL FOR CITIES X AND Y

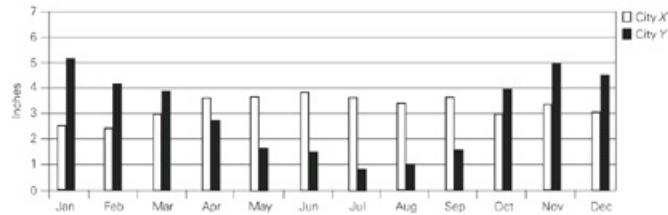

Question 11

For which of the following months does the average monthly high temperature for City X fall within one standard deviation of the average annual high temperature?
Indicate all possible values.

- January
- March
- May
- July
- September
- November

HONEY PRODUCTION IN REGION Z:
1980 TO 1986

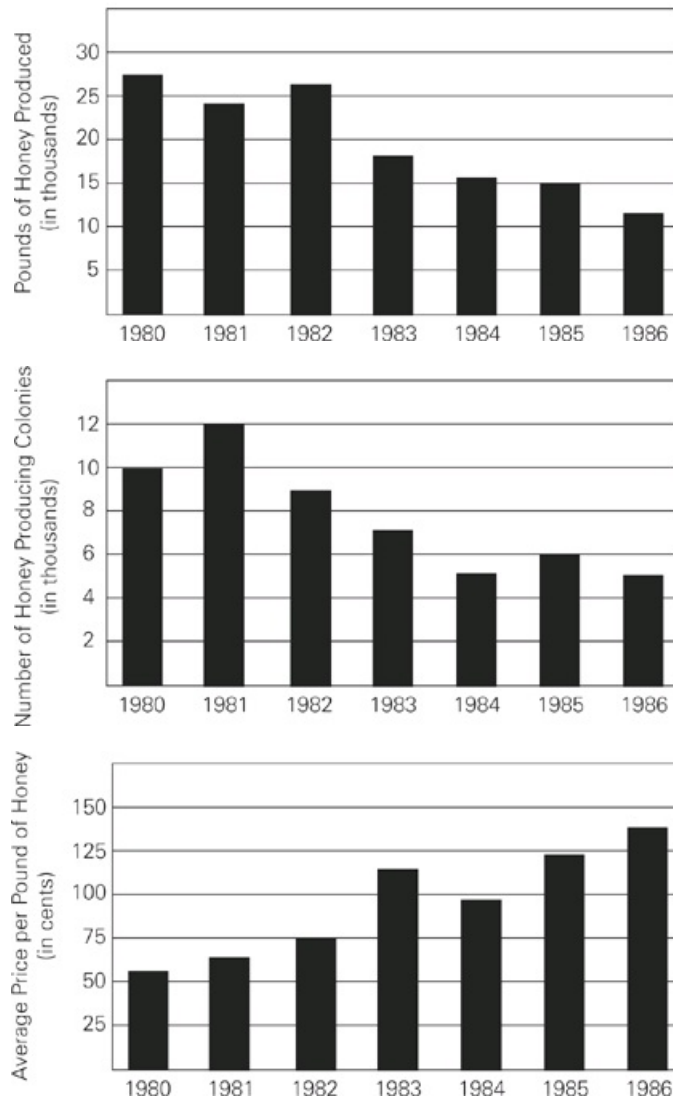

Question 12

For what year depicted in the graphs was the percent decrease from the previous year of the number of honey producing colonies most similar to the average percent increase of the average price of a pound of honey for the six-year period?

PRODUCTION OF GOLF EQUIPMENT AND SUPPLIES
 WORLD PRODUCTION 1994-1998
 (values are in millions of dollars)

Country	1994		1995		1996		1997		1998	
	Value	Percent of Total	Value	Percent of Total	Value	Percent of Total	Value	Percent of Total	Value	Percent of Total
United States	2,691	62.3	2,975	63.7	3,248	65.1	3,424	65.1	3,438	63.2
Japan	678	15.7	752	16.1	793	15.9	831	15.8	876	16.1
South Korea	376	8.7	383	8.2	384	7.7	426	8.1	457	8.4
Germany	177	4.1	159	3.4	180	3.6	179	3.4	201	3.7
Great Britain	125	2.9	140	3.0	135	2.7	153	2.9	169	3.1
Canada	125	2.9	103	2.2	105	2.1	100	1.9	125	2.3
Argentina	99	2.3	103	2.2	95	1.9	100	1.9	114	2.1
Other Countries	49	1.1	55	1.2	50	1.0	47	0.9	60	1.1
Total	4,320	100	4,670	100	4,990	100	5,260	100	5,440	100

UNITED STATES PRODUCTION

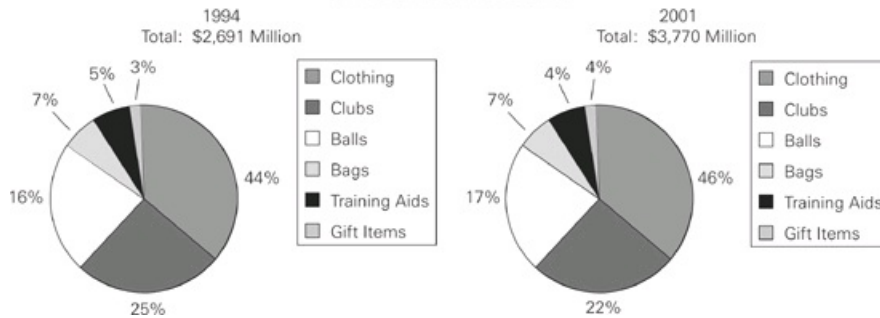

(Click [here](#) to view a larger image.)

Question 13

Golf equipment manufacturing in the United States experienced the same percent growth rate from 2001 to 2008 as it did from 1994 to 2001. If the share of golf supplies production made up of bags, balls and training aids each increased anywhere from 1% to 5% from 2001 to 2008, which of the following could be the sum of the value of bags, balls and training aids produced in the United States in 2008, in millions of dollars?

Indicate all possible values.

- 1,550
- 1,627
- 1,855
- 2,197
- 2,339

Question 14 refers to the following data.

Tree	Number of Individuals	Number of Trees	Standard Deviation of Diameter
Oak	64	58	11.2
Maple	50	42	7.4
Hickory	12	17	9.6
Ash	8	39	14.5
Birch	7	25	12.0

Question 14

How many maple trees had a diameter greater than 49.4 cm?

DRILL 4

Questions 1-3 refer to the following data.

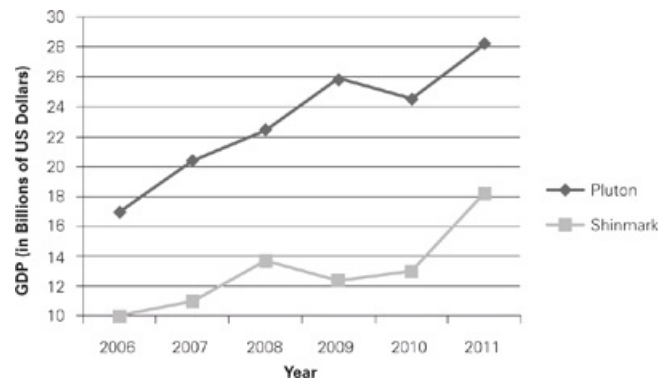

Question 1

Approximately what was the percentage growth of Pluton's GDP from 2010 to 2011 ?

- 4%
- 15%
- 25%
- 40%
- 115%

Question 2

In which year was the change from the prior year of the combined GDP of the two countries the least?

Question 3

Shinmark spends $\frac{1}{2}$ of its GDP on military expenditures, while Pluton spends $\frac{1}{4}$ of its GDP on military expenditures. For which years does Shinmark's military spending exceed Pluton's?

Indicate all possible values.

- 2006
- 2007
- 2008
- 2009
- 2010
- 2011

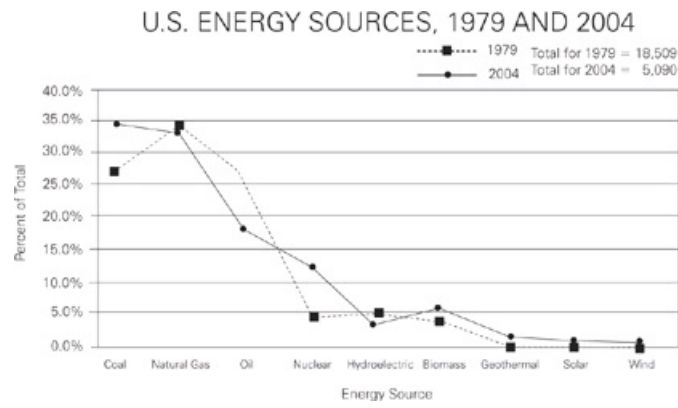

(Click [here](#) to view a larger image.)

Question 4

The population of the U.S. grew by 29% between 1979 and 2004, during which time per capita energy consumption doubled. If average per capita energy used from coal was 25 MBTUs in 1979, which of the following are in the range of per capita energy, measured in MBTUs, provided by a single fossil fuel (coal, natural gas or oil) in 2004 ?

Indicate all possible values.

- 12
- 25
- 37
- 41
- 61
- 79

AIRLINE DEPARTURES BY COUNTRY
IN 1990 AND 2001

Country	1990 (percent)	2001 (percent)
United States	24.2	31.1
United Kingdom	10.8	9.5
France	9.1	5.0
Germany	5.5	6.2
Japan	4.3	3.1
Brazil	3.1	4.0
China	2.0	7.7
Spain	1.2	0.3
Australia	0.8	0.6
All Others	39.0	32.5
Total Number of Departures	12,050,205	18,205,301

Question 5

To the nearest percent, what was the percentage increase for the country that experienced the greatest percent increase in number of departures between 1990 and 2001 ?

Questions 6-9 refer to the following data.

The following graph is a training log for a triathlete. It documents the number of hours she trained each week at each of three disciplines over a four week period.

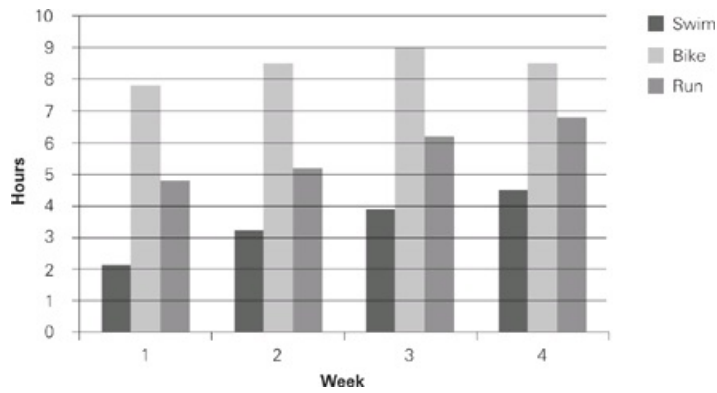

Question 6

Which of the following fall within the range of ratios of hours spent biking to hours spent swimming per week in this four week period?

Indicate all possible values.

- 1:4
- 1:2
- 2:1
- 3:1
- 3:2

Question 7

The athlete aims to spend between 12 and 16 percent of her weekly training time swimming. For which of the weeks does her swimming fall within that range?

- 1
- 2
- 3
- 4

Question 8

The athlete's average running pace is 7 miles per hour every week. How many miles did she run in week 2 ?

- 0.7
- 5.1
- 36.4
- 44.6
- 161.0

Question 9

In week 5, the athlete plans to decrease her training time in each sport by 10% to 20% of the hours she trained in week 4. Which of the following are possible numbers of hours she could bike in week 5?

- 5.6
 - 7.2
 - 9.8
 - 16.6
 - 22.8
-

MEMBERSHIP OF THE NORTH COUNTY AUTO
 MECHANICS AND AUTO SALES ASSOCIATIONS IN 1998

Auto Mechanics Association		Auto Sales Association
	Gender	
345	Male	500
464	Female	400
809	Total	900
	Age	
23	Youngest	25
68	Oldest	72
34	Average	44
	Number of Children	
125	0	209
223	1	126
204	2	98
117	3	85
54	4	132
52	5	128
34	6 or more	122
	Highest Education Level	
129	Some High School	185
286	High School Graduate	419
307	College Graduate	202
87	Advanced Degrees	94

(Click [here](#) to view a larger image.)

Question 10

Technology books have become an increasingly important subcategory of science/nature books. If technology books represent 30% of new adult science/nature books, half of used adult science/nature books, and $\frac{1}{10}$ of children's science nature books, how many technology books were sold in 2005?

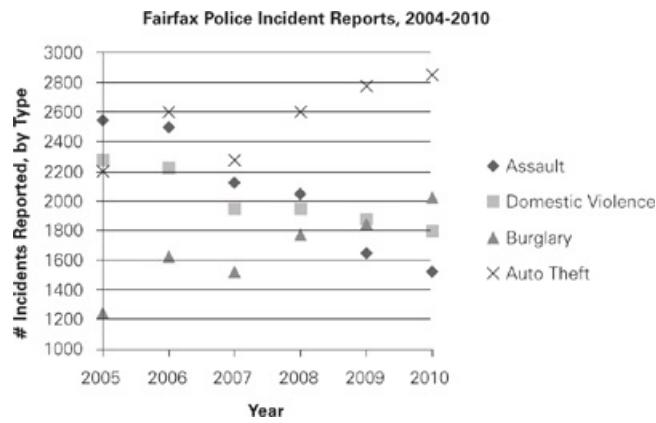

Question 11

The number of assaults reported in Fairfax dropped every year from 2004 to 2010. For which year(s) was the rate of decrease greater than it had been the previous year?

Indicate all possible values.

- 2006
- 2007
- 2008
- 2009
- 2010

Question 12

Total crime incidents reported in Fairfax decreased by 25% from 2005 to 2010. For which of the crime categories presented in the graph was the percent change from 2005 to 2010 greater than the percent change of all crimes reported?

Indicate all possible values.

- Assault
- Domestic violence
- Burglary
- Auto theft
- None of the above

2002 AIRPLANE INVENTORY FOR AIRLINES A AND B BY YEAR OF PURCHASE (as a percent of the 2002 inventory)

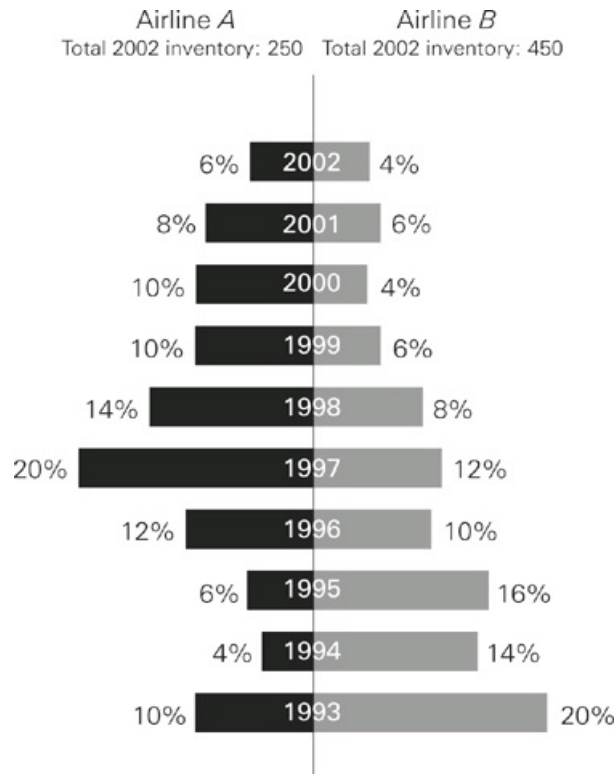

Question 13

New regulations go into effect in 2003 that require all planes in inventory to be newer than ten years old. Each year following 2002, both airlines need to sell the planes the regulations force them to eliminate from inventory, and then use the proceeds of those sales to increase their inventory by 10% (rounded down because they are unable to buy fractions of planes). What is the combined number of planes owned by the two companies following their sales and purchases in 2004 ?

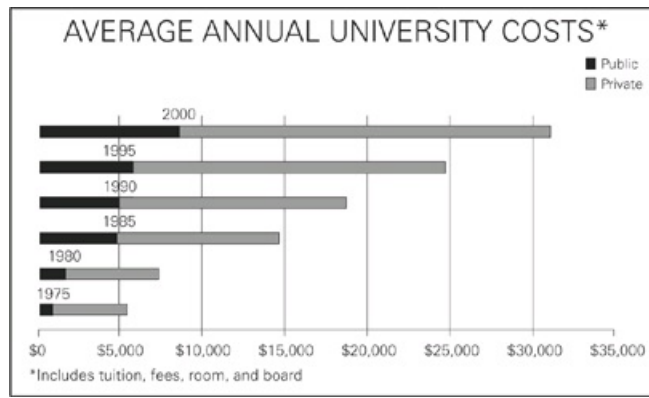

Question 14

The Great American Scholar (GAS) Grants cover 100% of students' tuition but no other expenses. In 1995, 4,000 GAS Grants were awarded, of which between $\frac{1}{4}$ and $\frac{1}{3}$ were mandated to go to public university students. In 1995, 50% of public university students' costs went to tuition, while 85% of private university students' costs went to tuition. Which of the following are possible total dollar values of all GAS Grants awarded in 1995 ?

- \$35,500,000
- \$42,000,000
- \$57,000,000
- \$64,000,000
- \$72,000,000
- \$96,000,000

ANSWERS

Drill 1

1. B
2. D
3. A
4. C
5. D
6. B
7. B
8. 3
9. 2
10. D
11. A
12. A
13. A
14. 464
15. E

Drill 2

1. D
2. A
3. B
4. A
5. D
6. B
7. B
8. C
9. D
10. B, C
11. C
12. A
13. D
14. A
15. B

Drill 3

1. D
2. D
3. C
4. C
5. D
6. E
7. D
8. A, B, C
9. 11,111
10. D
11. B, C, E, F
12. 1986
13. C, D
14. 8

Drill 4

1. B
2. 2010
3. A, B, C, E, F
4. C, D, E
5. 285
6. C, D
7. A
8. C
9. C
10. 109
11. B, D
12. A, C, D
13. 626
14. D

Drill 1

1. B Be sure you've identified the correct chart, the correct year, and the correct data line: Use the chart showing the number of yachts sold, the data line showing refurbished yachts, and the information for 1996. The data point for 1996 lies just below 6,000, so select choice (B). If you selected choice (A), you may have used the data line showing information for new yachts; if you selected choice (C), (D), or (E), you may have used information from the wrong year.
2. D Because the number of new yachts sold by Company J was always greater than the number of refurbished yachts it sold, a decrease in the former and an increase in the latter results in the two data lines coming closer together. Only the year 2001 shows the correct pattern and both of the proper changes: The number of refurbished yachts sold increased from about 6,200 to about 6,500, and the number of new yachts sold decreased from about 9,300 to about 8,800. The answer is choice (D).
3. A First, use the median price chart to determine that 2002 was the year when the median prices of new and refurbished yachts were most similar. Next, use the data line for refurbished yachts in the other chart to determine that the number of yachts sold by Company J that year was less than halfway from 6,000 to 7,000; only choice (A) falls in the acceptable range.
4. C In 1998, Springfield spent \$150,000 on safety and \$50,000 on recreation facilities; hence, the city spent three times as much on safety as on recreation facilities. If you selected choice (B), you may have used the wrong chart.
5. D In 1992, Springfield collected \$151,000 from income tax out of its total income of \$433,000; $\frac{\$151,000}{\$433,000}$ is slightly greater than $\frac{1}{3}$, so select choice (D).
6. B The percent change formula is $\frac{\text{difference}}{\text{original}} \times 100$, so, $\frac{532 - 433}{433} \times 100 = \frac{99}{433} \times 100$, or slightly less than a quarter (25%). The answer is choice (B).
7. B Round the values and use the percent change formula to approximate the answer; ignore the millions, because they are in both numbers. The percent change formula is $\frac{1}{3} \times 100$, so $\frac{18 - 12}{12} \times 100 = 50\%$.
8. 3 The chart already ranks the countries in order in 1990. In 2001, the rankings were: US—1st; UK—2nd; France—5th; Germany—4th; Japan—7th; Brazil—6th; China—3rd; Spain—9th; and Australia—8th. Only three countries—France, Japan, and Spain—ranked lower in 2001 than they did in 1990, making the answer 3.
9. 2 In 2003, only dogs and goldfish each accounted for more than 20% of the store's total sales.
10. D The number of goldfish sold in 2002 was 35% of 9,000, or 3,150 goldfish. The number of goldfish in 2003 was 40% of 10,000, or 4,000. To find the difference, simply subtract: $4,000 - 3,150 = 850$.
11. A Total cat sales in 2002 can be calculated as 10% of 9,000, or 900 total cats. In 2003, the figure is 9% of 10,000, or 900 total cats. Therefore, the same number of cats was sold in both years. The answer is choice (A).
12. A Store A and Store B both sold an equal number of pets in 2002, meaning both sold 4,500 animals. If the total number of pets sold by Store A then increases by 34%, Store A sold 6,030 animals in 2003. The total number of animals sold in 2003 was 10,000, meaning store B sold only 3,970 pets. Use the percent change formula: $\frac{4500 - 3970}{4500} \times 100$ to get choice (A).
13. A If 50 male members were replaced by 50 female members, there would be 450 male members and 450 female members. The ratio would be 1 to 1.
14. 464 Using the second column of the chart, there are 128 total men and women with 5 children, and you are given 92 women with 5 children. By subtracting, this leaves 36 men with 5 children. To find the total number of men who did not have 5 children, take the total number of all men (500) and subtract the number with 5 children (36). The answer is 464 men who did not have 5 children.
15. E There is not enough information given to answer this question since all, some, or none of the members who hold advanced degrees could also have 5 or more children.

1. D Use the first graph. Find the line that is the straightest across the four groups, thus, the line with the smallest range. Notice that the Reference line shows about 100, 120, 90, and 80 for the four groups. These numbers are more similar than any other category. For example, the numbers for Large Print are approximately 20, 90, 10, and 140. The range for Large Print ($140 - 10 = 130$) is much greater than the range for Reference ($120 - 80 = 40$). The answer is choice (D).
2. A Use the second graph. The section of the Used Adult bar for Science/Nature (grey portion) starts at approximately 80 and ends at approximately 150. So, the number of Science/Nature books is approximately $150 - 80 = 70$, choice (A).
3. B Use the first chart. There were approximately 220 New Adult (A) audio books, 330 New Children's (B) audio books, 50 Used Adult (C), and 200 Used Children's (D) audio books. Putting these in order from greatest to least gives you: (B) 330, (A) 220, (D) 200, (C) 50, choice (B).
4. A Be sure to Ballpark this one: 10% of \$120 million is \$12 million, so 5% would be \$6 million. Hence, we're looking for something just less than 5%. Of the options given, Fine Arts comes closest.
5. D Ballpark this one: $\frac{1}{2}$ of the university's New Construction expenditures is about 3%, $\frac{1}{4}$ of the Facility Maintenance expenditures is about 5%, and $\frac{3}{5}$ of the Athletics and Admissions/Scholarships expenditures is about 12%. That's a total of $3\% + 5\% + 12\% = 20\%$, and 20% of \$120 million is \$24 million, so the answer is choice (D).
6. B Athletic expenditures were 9.5%, while income was 6.1%; the difference is 3.4%, and $\frac{3.4}{9.5}$ can be ballparked to about $\frac{3.5}{10}$, or about 35%.
7. B First, look on the bar chart to figure out which months had an average rainfall greater than 3 inches and then apply that information to the temperature chart. According to the bar chart, the only months that had an average rainfall exceeding 3 inches were January, February, March, October, November, and December. According to the line chart, only two of those months had average lows exceeding 30 degrees: October and November.
8. C This is a multi-step problem, so you should take it one step at a time. First, determine the monthly midpoint for each month. The high in July is 78, and the low is 59, so the monthly midpoint is: $78 + 59 = 137 \div 2 = 68.5$. Similarly, the midpoint for August is: $76 + 57 = 133 \div 2 = 66.5$. September's midpoint is: $68 + 50 = 118 \div 2 = 59$. The average of the three midpoints is: $59 + 66.5 + 68.5 = 194 \div 3 = 64.7$, choice (C).
9. D For 1979, find 27.5% of 18,509, which is approximately 5,090. For 2004, find 17.5% of 20,623, which is approximately 3,609.
Round the numbers and reduce the ratio: $\frac{5000}{3600} = \frac{25}{18}$, choice (D).
10. B, C Choice (A) is incorrect; the graph gives no information on the number of power plants constructed. Choice (B) is correct. In 1979, coal and oil were each 26% and natural gas was 34% of total energy used, for a total of 68%. In 2004, coal was 34%, natural gas was 33%, and oil was 18% of total energy used, for a total of 85%. For choice (C), the amount of energy used from hydroelectric sources in 1979 is approximately 925 units and the amount for 2004 is approximately 203 units. You calculate these figures by using the different totals for each year and the percentage of total energy represented on the graph by hydroelectric energy. 203 is less than one fourth of 925, and thus choice (C) is valid.
11. C Avoid the temptation to work this problem in dollars—you can save considerable effort by dealing directly with the percentages. The pie chart for 1994 shows that clubs made up 25% of the total U.S. production, and the table shows that the United States accounted for 62.3% of the total world production; 25% (or $\frac{1}{4}$) of 62.3% is 15.575%, which is closest to choice (C), 16%.
12. A Start by adding the appropriate percentages from the pie chart for 1994: 16% (balls) + 7% (bags) + 3% (gift items) = 26%. Next, find the percentage for the United States total for that year: 26% of \$2,691 million is \$699.66 million. Finally, find the value in the chart that is nearest \$699.66 million—Japan, at \$678 million, is the closest.
13. D For this problem, be sure to get the correct dollar values from the chart and to use the percent change formula: $\frac{\text{difference}}{\text{original}} \times 100$.
Because the increase was from \$384 million in 1996 to \$457 million in 1998, the difference is \$73 million; $\frac{73}{384} \times 100$ reduces to 19.01%. The answer is choice (D). If you got choice (C), you may have mistakenly used the ending value, \$457 million, in place of

the original value.

14. A Since the problem asks for the approximate value of Region Z's honey production in 1985, you'll need to use the first and third graphs. The first graph tells you that there were about 15,000 pounds of honey produced that year, and the third graph tells you that each pound was worth just less than 125 cents, so try 120 cents—or, since the answer needs to be in dollars, \$1.20: 15,000 pounds \times \$1.20 per pound = \$18,000. The closest answer is choice (A).
15. B Use the graph to estimate your starting values and then use the percent change formula, which is $\frac{\text{difference}}{\text{original}} \times 100$. The largest number of colonies—about 12,000—was in 1981, while 1984 and 1986 appear to be tied for lowest at about 5,000 colonies. Since all values are in the thousands, simplify by calling your values 12 and 5: $\frac{12-5}{12} \times 100 = \frac{7}{12} \times 100$, which is approximately 60%. As always, watch out for trap answers: If you selected choice (A), you may have set the original value to 5 instead of 12.

1. D From 1997 to 1999, Airline A bought 44% of its 250 airplanes, or 110 airplanes. In the same time period, Airline B bought 26% of its 450 airplanes, or 117 airplanes. The sum of 110 and 117 is 227 airplanes, choice (D).
2. D Looking at the 2002 inventory at Airline A, 4% was purchased in 1994. The actual number in inventory is 4% of 250, or 10 airplanes. Of the 25 airplanes purchased, 15 must have been sold. Use percent translation to translate the question into algebra: “15 is what percent of 25” becomes $15 = \frac{x}{100} \times 25$. Solving for x gives you 60, choice (D).
3. C Although Airline A has fewer airplanes than does Airline B, you have no information about each airline’s customers; choice (A) is incorrect. While the percent of airplanes purchased by Airline B is twice as large as that purchased by Airline A, the actual number of airplanes purchased by Airline B is approximately four times as large as those for Airline A, not twice as large. So, choice (B) is incorrect. To evaluate choice (C), you need to add the percents in each column year by year until you get to 50%. The airplane with the median age for Airline A was purchased in 1997. For Airline B, the median is between 1995 and 1996, making the median age for the airplanes in Airline B’s inventory older. This validates choice (C), the only correct answer.
4. C The private : public ratio in 1990 was about $\frac{13}{5}$. Setting the ratios equal for the two years (setting up a proportion) gives you: $\frac{13}{5} = \frac{x}{11,000}$. The private cost is approximately \$29,000, so the answer is choice (C).
5. D The cost increases from about \$6,000 to \$22,000. Use the percent change formula to find the percent increase: $\frac{16,000}{6,000} \times 100 = 267\%$, so the answer is choice (D).
6. E The average cost of a private university in 1995 was \$17,000, and the cost in 2000 was \$22,000, as you discovered in the previous question. The increase over the 5-year period was \$5,000. If the average cost increased at a constant rate, then the increase was \$1,000 per year. The 3-year increase from 1995 to 1998 was therefore \$3,000, putting the average cost for a private university at \$20,000 in 1998. To find the total cost for that year, multiply the average cost per student times the number of students: $(\$20,000)(2.5 \text{ million}) = \50 billion . Similarly, in 1990, the total dollar amount spent on private universities was $(\$13,000)(2 \text{ million}) = \26 billion . The billions cancel out of the percent change formula, giving you $\frac{24}{26} \times 100 \approx 92\%$, which is the closest to choice (E).
7. D The fastest way to answer this question is to assign numerical values to the percentages given in the graphs. You can choose any numbers to work with and get the same answer, but since the graphs give percentages, choosing 100 total plants sold will make things easy. If total plants sold were 100, 71 were annuals. Of those 71 annuals, the second graph says that 24% were herbs. $24\% \times 71 = 17.04$. Since you started with 100 total plants, $17.04/100 = 17.04\%$. Choice (D) is nearest 17.04%, so it is the best answer.
8. A, B, and C
1,000 plants were sold, and from the first graph, you know that 71% of them, or 710, were annuals. Looking at the second graph, 40% of the 710 annuals, or 284, were tomatoes. Of those, any, all or none could have been Beefsteaks—you don’t know anything about that. So any number between 0 and 284 will work, making choices (A), (B), and (C) the correct answer.
9. 11,111 The key here is recognizing that the same percentage increase does not equal the same total increase of items. To find the percentage increase from 2002 to 2003, use the percentage change formula:

$$\frac{X_{\text{present}} - X_{\text{past}}}{X_{\text{past}}}$$

Plugging in 10,000 for X_{present} and 9,000 for X_{past} , you find an 11.1111% increase for 2002 to 2003. Since the problem said the percent increase was the same, find the increase in number of animals sold from 2003 to 2004: $11.1111\% \times 10,000 = 1111.11$ more animals in 2004. Adding that to the number sold in 2003 (10,000) yields 11,111.11 in 2004, which rounded to the nearest integer is 11,111.

10. D Before you add the number of violent and nonviolent crimes for each year, look at the chart to see if any of the years are so obvious that you don’t have to do the calculation. For 2009 and 2010, nonviolent crimes are clearly greater; for 2005, violent crimes are clearly greater. In 2006, there were about 4,700 violent crimes and 4,200 nonviolent crimes. In 2007, there were about 4,100 violent crimes and 3,800 nonviolent crimes. And in 2008, there were about 4,400 nonviolent crimes and 4,000 violent crimes. So for each of

the years 2008, 2009, and 2010, there were more nonviolent than violent crimes. The correct answer is choice (D).

11. B, C, E, and F
One standard deviation captures 68% of the data points, or 34% in each direction from the mean. For this question, that means that 68% of the months of the year will have average high temperatures within one standard deviation of the annual average high temperature. $12 \times 68\% = 8.16$, so 8 months will be within one standard deviation. Standard deviation assumes a “normal” (balanced on the high and low ends) distribution, so the 2 months with the greatest average monthly high temperature and the 2 with the lowest average monthly high temperature will fall outside of one standard deviation. To answer the questions, use POE to eliminate the 2 most extreme months on each end. (Note that you don’t have to calculate anything to find the correct answers.) It is clear that January has the lowest average high temperature, so eliminate choice (A). February probably comes next, but it doesn’t matter since neither it nor December is an answer choice. November is definitely not one of the two months with the lowest average high temperatures, so choice (F) is in. July has the highest average high temperature, so eliminate choice (D). Whether June or August is second doesn’t matter for us because neither is an answer choice, but that means March, May, September, and November all make the cut.
12. 1986 The question asks you to determine the overall average percent increase in the price per pound of honey and then compare that to each year’s annual percent decrease in the number of honey producing colonies to find the most similar, but opposite, number. To determine the average percent increase in the price of honey, find each year’s percent change using the percent change formula:

$$\frac{X_{\text{present}} - X_{\text{past}}}{X_{\text{past}}}$$

and then average those six numbers to get an average percent change of around 14%. For the other part of the problem, ignore the years in which number of colonies increases since the question asks for percent decrease from the previous year. Then find the percent change of the number of colonies for each remaining year. Using the same formula as above, from 1985 to 1986 the number of colonies decreases by about 14%. In fact, that is the only year in which the number decreases by less than 20%, so 1986 is the best answer.

13. C, D First, find the total U.S. production of golf goods in 2008. Calculate the percent change from 1994 to 2001 using the percent change formula:

$$\frac{X_{\text{present}} - X_{\text{past}}}{X_{\text{past}}}$$

with values of 3,770 for X_{present} and 2,691 for X_{past} . The percent change from 1994 to 2001 was 40.1%. Multiply the 2001 value by 40.1% and add that to the original value to find the 2008 production value of 5,282. Next, figure out the percentage of 2008 production that could be from balls, bags and training aids. In 2001, those three categories together made up $17\% + 7\% + 4\% = 28\%$ of production. If each category’s share of total production increased between 1% and 5%, the minimum the three categories together could have grown is 3%, and the maximum they could have grown is 15%. So, the minimum percent of production they represent in 2008 is $28\% + 3\% = 31\%$, and the maximum is $28\% + 15\% = 43\%$. The minimum production value they represent then is $31\% \times 5,282 = 1,637$, and the maximum is $43\% \times 5,282 = 2,271$. Correct choices (C) and (D) are the only answers that fall in that range.

14. 8 On each side of the mean, 34% of individuals fall within one, 14% of individuals fall within two, and 2% of individuals fall within three standard deviations. 49.4 cm is exactly one standard deviation above the mean maple tree diameter. Therefore, 16% of the maple trees will have a larger diameter larger than 49.4. $16\% \times 50 \text{ trees} = 8 \text{ trees}$.

1. B Remember the percent change formula:

$$\frac{X_{\text{present}} - X_{\text{past}}}{X_{\text{past}}}$$

All the values are in billions, so you can ignore all the zeroes and just use the smaller numbers from the graph. In this case, X_{past} is Pluton's 2010 GDP, or about 24.5, and X_{present} is Pluton's 2011 GDP, or about 28.2. Plug those into the percent change formula and use your on-screen calculator to get an answer of 15.1%, making choice (B) the best answer.

2. 2010 The question asks you to sum the two countries' GDPs for each year and determine the year in which the change from the year prior was the least. Rather than determining the GDP for each country for each year and adding and subtracting, glance at the graph and see if any years stand out as having significantly less increase than the others. In 2010, Pluton's GDP shrank by about \$1.5 billion and Shinmark's grew by \$0.5 billion, for a net decrease of about \$1 billion. In no other year was there a combined decrease, so 2010 must be the correct answer.

3. A, B, C, E, and F

You could calculate and compare $\frac{1}{2}$ of Shinmark's GDP to $\frac{1}{4}$ of Pluton's for each year. Alternatively, multiply both of the fractions by 4 to make the numbers easier to deal with; compare twice Shinmark's GDP to all of Pluton's. Looking at the graph, the only year that twice Shinmark's GDP isn't greater than Pluton's is 2009, so for all the other years, Shinmark's military spending exceeds Pluton's.

4. C, D, and E

Ignore the population growth: The question is asked in per capita terms, so it's asking about the population as a whole. Coal production was 25 in 1979, when, according to the graph, coal represented 27% of energy; since 25 is 27% of 92.6, the total energy was 92.6 in 1979, and double that, or 185.2, in 2004. The lower end of the range is oil, at about 17%, and 17% of 185.2 is about 31.5; the upper end of the range is coal, at about 34%, or about 63. Choices (C), (D), and (E) fall within the range.

5. 285 By inspecting the departures for all the countries in the table, China by far has the greatest increase in percentage of total number of departures. While no other country has even doubled its departure percentage, China has nearly quadrupled its percentage. Once you notice that, you need to remember the percentage change formula:

$$\frac{X_{\text{present}} - X_{\text{past}}}{X_{\text{past}}}$$

Then you can just plug in 2.0 for X_{past} and 7.7 for X_{present} and find the correct answer: 285.

6. C, D You could calculate the ratio for each week and determine the range from the most extreme values. Alternatively, you might notice that hours biked remain relatively constant while hours swam increase, so weeks 1 and 4 will represent the ends of the ratio. In week 1, she biked about 7.8 hours and swam about 2.1, which, dividing 7.8 by 2.1, reduces to a ratio of $\sim 3.7:1$. In week four she biked about 8.5 hours and swam about 4.5 hours, which reduces to a ratio of $\sim 1.9:1$. The range of ratios, from 1.9:1 to 3.7:1, includes 2:1 and 3:1, but none of the others. The ratio 3:2 can be rewritten as 1.5:1, and then it's easy to see that doesn't fall within that range.

7. A To determine the percent of training time dedicated to swimming, divide the time spent swimming by the total training time and multiply by 100. For example, in week 1, the athlete swims 2.1 hours and trains a total of 14.7 hours, so she spent a little over 14% of her training time swimming. Week 2, swimming represents about 19%; week 3, 20%; and week 4, 23%. Week 1 is the only week for which swimming represents between 12 and 16% of total training time, so choice (A) is the correct answer.

8. C Remember that Rate = Distance / Time. Since you are solving for distance, rearrange to get Distance = Rate \times Time. In this case Rate = 7 miles per hour, and from the graph, Time = 5.2 hours. $7 \times 5.2 = 36.4$.

9. C You can determine what hours make a 10 – 20% decrease by calculating 10% and 20% of the original value and subtracting, or, to save time, just calculate 90% and 80% of the original value. She biked 8.5 hours in week 4. $80\% \times 8.5 = 6.8$, and $90\% \times 8.5 = 7.7$, so any number of hours between 6.8 and 7.7 will be acceptable. Choice (C) is the only answer that falls in that range.

10. 109 Use the second table in the diagram. First, to find the number of technology books in each category, you need to multiply the percentages or fractions by the total numbers of books sold for each respective category of science/nature books. Then add all those together to find the correct answer. For new adult: $30\% \times 150 = 50$. For used adult: $0.5 \times 70 = 35$. For new children's: $0.1 \times 120 = 12$. For used children's: $0.1 \times 120 = 12$. The final answer is $50 + 35 + 12 + 12 = 109$.

11. B and D

Rather than calculating, think in terms of the slope of the line connecting successive data points for assault. A greater rate of increase means a more sharply sloping downward line: The line from 2006 to 2007 is steeper than the one from 2005 to 2006, so choice (B) is correct, and the line from 2008 to 2009 is steeper than the one from 2007 to 2008, so choice (D) is also correct. For all the other

years, the decrease in assaults is less than the previous year, so only choices (B) and (D) are correct.

12. A, C, and D

To find the percent change, use the percent change formula, $\frac{\text{difference}}{\text{original}} \times 100$, and be sure to use the values for 2005 as the original.

Assaults changed by 40%, burglary changed by 62%, and auto theft changed by 30%, so choices (A), (C), and (D) are correct. Only domestic violence, which changed 21%, didn't change more than 25%.

13. 626 You have to calculate how many planes each company sells and buys for 2003 and 2004 in order to calculate the total number of planes in 2004. In 2003, each company sells the planes they bought 10 years prior in 1993. For A: $250 \times 10\% = 25$ planes removed; for B, $450 \times 20\% = 90$ planes removed. In 2003 A has only 225, so they add 10%, or 22 new planes, for a new total of 247, and B has 360 left, so they add 36 for a new total of 396. In 2004, they sell the old planes they bought in 1994: For A, $250 \times 4\% = 10$ planes; for B, $450 \times 14\% = 63$ planes. Now A has $247 - 10 = 237$, so they add 23 for a 2004 total of 260. B now has $396 - 63 = 333$, so they add 33 for a 2004 total of 366. $260 + 366 = 626$ planes in 2004.

14. D The grants cover just tuition, so you first need to find the costs of tuition for public and private university students in 1995. From the graph, a public student's average total costs were about \$6,000 and the question says that 50% of that went to tuition, or \$3,000. For private students, average total costs were about \$24,500 and 85% was went to tuition, or \$20,825. Now you need to multiply those average tuition costs by the number of students in each university type that got a grant to get the total dollars awarded. Between $\frac{1}{4}$ and $\frac{1}{3}$ of the 4,000 awardees were public university students, or between 1,000 to 1,333 students. The other 2,667 to 3,000 were private university students. Since private tuition is more than public tuition, the high end of the total grant range will be if the most private students and the least public students got the grants: $3,000 \text{ private students} \times \$20,825/\text{student} + 1,000 \text{ public students} \times \$3,000/\text{student} = \$65.48 \text{ million}$. The low end of the range will be if the most public school students and the least private students possible got the grants: $2,667 \text{ private students} \times \$20,825/\text{student} + 1,333 \text{ public students} \times \$3,000/\text{student} = \$59.55 \text{ million}$. The only answer choice that falls between \$59.55 and \$65.48 million is choice (D).



Linear Equations and Inequalities

LINEAR EQUATIONS AND INEQUALITIES

Linear equations are simply problems that require manipulating the equations and solving for x . In a general sense, your job is to get all the numbers on one side and all the letters on the other. Whatever you do to one side, you must do to the other so that they remain equal. You can subtract a number from both sides. You can divide both sides by a variable so that it disappears from one side and its reciprocal shows up on the other.

As you are manipulating your equations, make sure that you aren't doing more work than you have to. If the question asks for the value of $3x$, you don't need to know the value of x , only $3x$. If you are asked for the value of $2x + 2y$, you may not need to know the actual value of either x or y —just manipulate the equation into a $2x + 2y$ format.

If you have a $>$, $<$, \geq , or \leq sign, the processes remain exactly the same with one exception: If you multiply or divide by a negative number, you must reverse the sign.

USE PLUGGING IN

Don't forget that you can always Plug In if you're given the right conditions. If you have variables in the answer choices, Plug In. If it is a Quant Comp, this means making your set-up. If it is a problem-solving question, you must write down your answer choices, label your terms, circle your target number, and check all of your answer choices.

If you see the phrase "how much," "how many," or "what is the value of," you can plug in the answer choices. Label your first column—assume choice (C) to be the correct answer choice—and work through the problem in bite-sized pieces, making a new answer choice for every step.

SIMULTANEOUS EQUATIONS

You may also see simultaneous equations. This means that you have two equations with two variables or three equations with three variables. To get rid of one variable, you simply stack the equations, line up the variables and either add or subtract the equations. Your goal is to nullify one variable so that you can solve for the other.

Example:

$$\begin{array}{r} 2x + 3y = 12 \\ + \quad x - 3y = 3 \\ \hline 3x \qquad = 15 \\ x = 5 \end{array}$$

When you add these two equations, the y 's cancel out and you're left with only x 's. If you're not sure whether to add or subtract, don't worry, just try one. If it doesn't work, try the other. Sometimes you may have to manipulate an equation a bit in order to make sure that one variable cancels out. For example, if you were to add

$$\begin{array}{r} 2x + 3y = 12 \\ x - y = 3 \end{array}$$

...you wouldn't get very far. However, if you multiply the second equation by three (remember that whatever you do on one side of the equal sign you must do on the other), you can get the y 's to cancel out.

$$\begin{array}{r} 2x + 3y = 12 \quad 2x + 3y = 12 \\ 3(x - y = 3) = + \quad 3x - 3y = 9 \\ \hline 5x \qquad = 21 \\ x = \frac{21}{5} \end{array}$$

For more practice and a more in-depth look at The Princeton Review math techniques, check out our student-friendly guidebook, *Cracking the New GRE*.

DRILL 1

Question 1

$4c + 6 = 26$. What is the value of $3c - 2$?

- $-\frac{1}{2}$
- 4
- 5
- 13
- 22

Question 2

$$\text{Quantity A}$$

$$\frac{3k - 12j}{9}$$

$$\text{Quantity B}$$

$$\frac{k - 4j}{3}$$

- Quantity A is greater.
- Quantity B is greater.
- The two quantities are equal.
- The relationship cannot be determined from the information given.

Question 3

What is the value of $(n - 5)(m + 5)$ when $n = -5$ and $m = 5$?

- 100
- 10
- 0
- 10
- 100

Question 4

$$\frac{2}{3}y = \frac{1}{8}$$

$$\text{Quantity A}$$

$$y$$

$$\text{Quantity B}$$

$$\frac{1}{12}$$

- Quantity A is greater.
- Quantity B is greater.
- The two quantities are equal.
- The relationship cannot be determined from the information given.

$$7a + 8 = 8a - 24$$

Quantity A

a

Quantity B

24

- Quantity A is greater.
- Quantity B is greater.
- The two quantities are equal.
- The relationship cannot be determined from the information given.

Question 6

If x does not equal 0 or 1, the expression $\frac{\frac{1}{x} - 1}{\frac{1}{x}}$ is equivalent to which of the following?

- $\frac{x}{x-1}$
- $x - 1$
- -1
- $1 - x$
- 1

Question 7

$$0 < a < b < 1$$

Quantity A

0

Quantity B

 $2(a - b)$

- Quantity A is greater.
- Quantity B is greater.
- The two quantities are equal.
- The relationship cannot be determined from the information given.

Question 8

If $a \geq 30$ and $b \leq 15$, then which of the following must also be true?

- $a - b \leq 45$
- $a - b \leq 15$
- $a - b \geq 15$
- $a + b \leq 45$
- $a + b \geq 45$

Question 9

Lyle bought used CDs at a store where all the CDs cost either \$8 or \$12. If Lyle bought an equal number of CDs at each price, and he spent a total of \$200, what was the total number of CDs that Lyle bought?

Question 10

What is the greatest integer that does NOT satisfy $3(x - 9) < 5x - 2(1 - 3x)$?

- 4
 -3
 0
 3
 4

Question 11

If $y = 4$ is a solution of the equation $y^2 + ay + 8 = 36$, then what is the value of a ?

- 7
 -4
 -3
 3
 7

Question 12

$$a = 4$$

$$6 < b < 8$$

Quantity A

0.6

Quantity B

$\frac{a}{b}$

- Quantity A is greater.
 Quantity B is greater.
 The two quantities are equal.
 The relationship cannot be determined from the information given.

Question 13

If $a = 3b + 2$, then, in terms of a , what is the value of b ?

- $b = \frac{a}{3} - \frac{2}{3}$
 $b = \frac{a}{3} + \frac{2}{3}$
 $b = \frac{a}{3} - 2$

- $b = a - \frac{2}{3}$
- $b = a + \frac{2}{3}$

Question 14

If $b = \frac{4a}{c}$, a is halved, and c is doubled, by what percentage will b decrease?

- 4%
- 25%
- 50%
- 75%
- 100%

Question 15

If $\frac{1}{2x} + \frac{2}{x} = \frac{5}{8}$, what is the value of x ?

- 2
- 3
- 4
- 7
- 8

Question 16

Every box of cookies contains exactly 6 cookies.

Quantity A

The total number of cookies purchased if Sally purchased 3 more than twice as many boxes of oatmeal cookies as boxes of chocolate chip cookies

Quantity B

The total number of cookies purchased if Sally purchased 2 fewer than 3 times as many boxes of oatmeal cookies as boxes of chocolate chip cookies

- Quantity A is greater.
- Quantity B is greater.
- The two quantities are equal.
- The relationship cannot be determined from the information given.

DRILL 2

Question 1

What is the value of $\frac{xy}{z^2}$ when $z = 3x$, $y = 4z$, and $xy \neq 0$?

- 12
- $\frac{4}{3}$
- 1
- $\frac{3}{4}$
- $\frac{1}{12}$

Question 2

The sum of two integers is 27. The larger integer is 25% greater than the smaller integer. What is the positive difference between the two integers?

- 3
- 6
- 9
- 12
- 15

Question 3

What is the product of the factors of twice the sum of the roots of the equation $2x^2 - 4x - 6 = 0$?

Question 4

If a is a positive even integer, and ab is a negative even integer, then b must be which of the following?

- A negative number
- A negative even integer
- A negative integer
- A positive even integer
- A positive integer

Question 5

$-1 < a - b < 10$, with b an integer such that $-3 \leq b \leq 1$. What most accurately describes the range of a^2 ?

- $-16 < a^2 < 11$
- $-4 < a^2 < 11$
- $0 < a^2 < 16$

$0 < a^2 < 121$

$16 < a^2 < 121$

Question 6

If $0.5(y - x) = -1$ and $x^2 - y^2 = 24$, what is the sum of x and y ?

-48

-12

6

12

48

Question 7

The quotient of x and y is 2. If x is 75% of z , which is $\frac{3}{4}$ larger than w , what is w in terms of y ?

$\frac{21}{32}y$

$\frac{20}{21}y$

$\frac{32}{21}y$

$\frac{32}{9}y$

$\frac{21}{8}y$

Question 8

The sum of x and y is at least 2 but no more than 5. If the total of twice x and three times y is non-negative and no more than 40, which of the following expresses all possible values of y ?

$-4 \leq y \leq 36$

$-10 \leq y \leq 30$

$-10 \leq y \leq 36$

$0 \leq y \leq 40$

$2 \leq y \leq 5$

Question 9

$$\left(\frac{1}{x}\right) + \left(\frac{1}{y}\right) = 6$$

$$-\frac{1}{3} = -2\left(\frac{zy}{z+y}\right)$$

Quantity A

Quantity B

- Quantity A is greater.
- Quantity B is greater.
- The two quantities are equal.
- The relationship cannot be determined from the information given.

Question 10

a , b , and c are integers such that $ab + c = 7$, $ac + b = 5$, and $a + b + c = 6$. What is the value of abc ?

- 2
- 6
- 9
- 12
- 18

Question 11

If $-4 \leq a \leq 9$, and $-3 \leq b \leq 2$, then what is the greatest possible value of $a - b$?

Question 12

If $m - n > 3$, then which of the following must be true?

Indicate all possible values.

- m is an integer
- n is an integer
- $m > n$
- $m + n > 0$
- $m - n > 0$
- $m \times n > 0$
- $m \div n > 0$

Question 13

All of the students in a certain class are either 7 or 8 years old. 80 percent of the students are boys and 25 percent of the girls are 8 years old. If there are an equal number of 7-year-olds and 8-year-olds, what percent of the students in the class are boys who are 7 years old?

Question 14

If $-12 < x < -2$ and $3 < y < 6$, which of the following could equal xy ?

Indicate all possible values.

- 36
- 27

-6

-1.5

0

1.5

Question 15

If $x^{-2} - 2 = -1.96$, $y^{1/3} - 5 = -2$, and $xy > 0$, then what is the value of xy ?

ANSWERS

Drill 1

1. D
2. C
3. A
4. A
5. A
6. D
7. A
8. C
9. 20
10. A
11. D
12. D
13. A
14. D
15. C
16. D

Drill 2

1. B
2. A
3. 8
4. A
5. D
6. D
7. C
8. C
9. C
10. B
11. 12
12. C, E
13. 35
14. A, B, C
15. 135

Drill 1

- D When solving algebraically, be careful to perform the same operation on both sides of the equation: $4c + 6 = 26$, so subtract 6 from both sides to find $4c = 20$ and $c = 5$. Therefore, $3c - 2 = (3 \times 5) - 2 = 13$.
- C You can find the two quantities to be equal by plugging in values for k and j : If $k = 2$ and $j = 3$, then Quantity A is $\frac{3(2) - 12(3)}{9}$, or $-\frac{30}{9}$, which can be reduced to $-\frac{10}{3}$; Quantity B is $\frac{2 - 4(3)}{3}$, or $-\frac{10}{3}$. Algebraically, try factoring and canceling a 3 out of the numerator of Quantity A: $\frac{3k - 12j}{9} = \frac{3(k - 4j)}{3 \times 3} = \frac{k - 4j}{3}$.
- A Start by substituting the given values for the variables in the equation. You'll be left with $(-5 - 5)(5 + 5)$, which simplifies to $(-10)(10)$, or -100 .
- A Solve the given equation by multiplying both sides of the equation by $\frac{3}{2}$. You get a value of $\frac{3}{16}$ for y . Then use the Bowtie method to compare the fractions in the quantities; the fraction in Quantity A is greater.
- A To solve this single-variable equation, you'll just need to isolate the variable. First, add 24 to both sides to yield $7a + 32 = 8a$. Then subtract $7a$ from both sides to yield $32 = a$. Quantity A is greater.
- D You are told that $\frac{\frac{1}{x} - 1}{\frac{1}{x}}$, which you can manipulate to $(\frac{1}{x} - 1)(\frac{x}{1}) = \frac{x}{x} - \frac{x}{1} = 1 - x$, so the answer is choice (D). Alternatively, you can solve this "must be" problem by plugging in values for x : If $x = 2$, then $\frac{\frac{1}{x} - 1}{\frac{1}{x}} = \frac{\frac{1}{2} - 1}{\frac{1}{2}} = \frac{-\frac{1}{2}}{\frac{1}{2}} = -\frac{1}{2} \times \frac{2}{1} = -1$. Eliminate choices (A), (B), and (E), because none of them hit your target of -1 . Next, try $x = 3$: Now $\frac{\frac{1}{x} - 1}{\frac{1}{x}} = \frac{\frac{1}{3} - 1}{\frac{1}{3}} = \frac{-\frac{2}{3}}{\frac{1}{3}} = -\frac{2}{3} \times \frac{3}{1} = -2$; eliminate choice (C).
Choice (D) gives the target answer of -2 , so it is the correct answer.
- A You know that b is greater than a , so $(a - b)$ will always be negative, and Quantity A will always be greater. Alternatively, you can solve this one by plugging in values for a and b . Try making $a = \frac{1}{4}$ and $b = \frac{1}{2}$: The value in Quantity B is now $2\left(\frac{1}{4} - \frac{1}{2}\right) = 2\left(-\frac{1}{4}\right) = -\frac{1}{2}$. Quantity A is greater, so eliminate choices (B) and (C).
- C Solve this "must be" problem by plugging in values for a and b . Starting with the simplest allowable values, $a = 30$ and $b = 15$, does not eliminate any answer choices. Next, try $a = 100$ and $b = 0$; now choices (A), (B), and (D) can be eliminated. Finally, try $a = 30$ and $b = -30$; now choice (E) can be eliminated, leaving only choice (C), which is the correct answer.
- 20 Since Lyle bought an equal number of CDs at each price, combine the prices: 1 CD of each type would cost $\$8 + \$12 = \$20$. For a total of $\$200$, then, Lyle bought $\frac{\$200}{\$20} = 10$ CDs of each type, for a total of 20 CDs altogether.
- A The given inequality is equivalent to $3x - 27 < 11x - 2$, which becomes $-8x < 25$. Dividing both sides by -8 (and flipping the inequality sign), you get $x > -3\frac{1}{8}$. Therefore, any number that is greater than $-3\frac{1}{8}$ will satisfy the inequality, so the greatest integer that does not satisfy it is $x = -4$, choice (A).
- D Replace y with 4 to get $16 + 4a + 8 = 36$. Then solve the equation to find that a equals 3.

12. D Start by combining the 2 given equations: If $a = 4$ and $6 < b < 8$, then the acceptable range for $\frac{a}{b}$ is $\frac{4}{6} > \frac{a}{b} > \frac{4}{8}$, which can be reduced to $\frac{2}{3} > \frac{a}{b} > \frac{1}{2}$ or, in decimal form, $0.5 < \frac{a}{b} < 0.67$. Select choice (D) because $\frac{a}{b}$ can be either larger or smaller than 0.6.
13. A The problem has variables in the answer choices so Plug In. Because the problem says, "in terms of a," a is the variable that you want to plug in for. If $a = 8$, then $b = 2$, and that is now your target. When you plug in your value for a into choice (B), you get $\frac{8}{3} - \frac{2}{3} = \frac{6}{3} = 2$; thus, the correct answer.
14. D Try plugging in values for a and c. Let $a = 6$ and $c = 2$. Then $b = \frac{4(6)}{2} = 3$. If a is halved, equal it will 3. If c is doubled, it will equal 4. So now, $b = \frac{4(3)}{4} = 3$. Because the question is looking for a percentage decrease, apply the percentage change formula: $\frac{12-3}{12} \times 100 = \frac{9}{12} \times 100 = \frac{3}{4} \times 100 = 75\%$.
15. C Plug In The Answers starting with choice (C). Choice (C) yields $\frac{1}{8} + \frac{2}{4} = \frac{1}{8} + \frac{4}{8} = \frac{5}{8}$, so it's the correct answer.
16. D First, plug in 1 for the number of boxes of chocolate chip cookies. In Quantity A, if Sally buys 1 box of chocolate chip cookies, then she buys $2(1) + 3 = 5$ boxes of oatmeal cookies, for a total of 6 boxes, or 36 cookies. In Quantity B, if Sally buys 1 box of chocolate chip cookies, then she buys $3(1) - 2 = 1$ box of oatmeal cookies, for a total of 2 boxes, or 12 cookies. Quantity A is greater, so eliminate choices (B) and (C). Now plug in 10 boxes of chocolate chip cookies: Quantity A is now $2(10) + 3 = 23$ boxes of oatmeal cookies, for a total of 33 boxes, or 198 cookies, and Quantity B is now $3(10) - 2 = 28$ boxes of oatmeal cookies, for a total of 38 boxes, or 228 cookies. Quantity B is now greater, so eliminate choice (A), and you're left with choice (D).

1. B You know that $\frac{xy}{z^2}$, so solve this one by plugging in values for z , x , and y . If $x = 12$, then $z = 36$ and $y = 144$; $\frac{xy}{z^2} = \frac{12 \times 144}{36^2} = \frac{4}{3}$.

The correct answer is choice (B).

2. A Use the information in the problem to write the equations $x + y = 27$ and $\frac{x}{4} + x = y$. You can combine these two equations to say that $\frac{x}{4} + x + x = 27$. When you solve this new equation you find that $x = 12$. You can then go back to your first equation and find that $y = 15$. The positive difference between 15 and 12 is 3, so select choice (A).
3. 8 First, factor the quadratic: $(2x + 2)(x - 3) = 0$. Next, solve for each solution (root). If $2x + 2 = 0$, then $x = -1$. If $x - 3 = 0$, then $x = 3$. The sum of the roots is 2, and twice their sum is 4. The factors of 4 are 1, 2, 4, and the product of those factors is 8, the final answer.
4. A The problem contains the phrase “must be,” so try to find numbers to plug in that disprove four of the five answer choices. If $a = 4$ and $ab = -12$, then $b = -3$; eliminate choices (B), (D), and (E). Now determine whether b must be an integer. If $a = 4$ and $ab = -2$, then $b = -\frac{1}{2}$; eliminate choice (C), and you’re left with choice (A), the correct answer.
5. D If a range of values for a can be found, then the range of values for a^2 can be found. Start by testing the end values of b , -3 and 1 . Plug in -3 for b in the first given inequality then solve for a . You find that $-4 < a < 7$. If $b = 1$, $0 < a < 11$; b could be any integer in the range $-3 \leq b \leq 1$, this means $-4 < a < 11$ overall. Remember to take the last step, though! The question is looking for the range of a^2 , not a ; a^2 is always positive (i.e., $0 < a^2$). Because $a < 11$, $a^2 < 121$. This means $0 < a^2 < 121$; the answer is choice (D).
6. D Know your common quadratics. You are asked for the value of $x + y$. Because $x^2 - y^2 = (x + y)(x - y) = 24$, if the value of $(x - y)$ is found, $(x + y)$ can be figured out. Manipulate the equation $0.5(y - x) = -1$ to get $(y - x) = -2$. Multiplying both sides by -1 , you get $x - y = 2$. Substitute this value into the equation $(x + y)(x - y) = 24$ and then divide both sides of the equation by 2 to get $(x + y) = 12$. The answer is choice (D).
7. C Translate what you are told into algebra: $\frac{x}{y} = 2$ and $x = \frac{75}{100} \times z = \frac{3}{4}z$. Notice that the problem then tells you that z is $\frac{3}{4}$ larger than w , not z is $\frac{3}{4}$ of w . That means $z = w + \left(\frac{3}{4}w\right) = \left(1 + \frac{3}{4}\right)w = \frac{7}{4}w$. At this point, you can either Plug In or do algebra. To Plug In, choose 4 for w , so $z = 7$, and $x = \frac{3}{4} \times 7 = \frac{21}{4}$. If $\frac{x}{y} = 2$, then $x = 2y$, so $\frac{21}{4} = 2y$; $y = \frac{21}{8}$. Now plug $\frac{21}{8}$ into the answer choices for y to see which hits your target number, $w = 4$. Only choice (C) does. Alternatively, to do algebra, combine the first two equations you translated into algebra: $2y = \frac{3}{4}z$; $z = \frac{8}{3}y$. Combining this equation with the one you derived above, it follows that $\frac{8}{3}y = \frac{7}{4}w$, and $w = \frac{32}{21}y$; the answer is choice (C).
8. C Translate what you are told into algebra: $2 \leq x + y \leq 5$ and $0 \leq 2x + 3y \leq 40$. By manipulating the inequalities, you find that $2 - y \leq x \leq 5 - y$ and $-2x \leq 3y \leq 40 - 2x$. Substitute the endpoints of the values of x into the second inequality: $-2(2 - y) \leq 3y \leq 40 - 2(2 - y)$ and $-2(5 - y) \leq 3y \leq 40 - 2(5 - y)$. By solving for y , the first range yields $-4 \leq y \leq 36$, and the second yields $-10 \leq y \leq 30$, meaning $-10 \leq y \leq 36$ overall.
9. C Using the Bowtie method, you find that $\frac{y+x}{xy} = 6$. By multiplying both sides of the second equation by $-\frac{1}{2}$, you find that $\frac{1}{6} = \frac{zy}{z+y}$. Flipping both fractions yields $\frac{z+y}{zy} = 6$, and thus, $\frac{y+x}{xy} = \frac{z+y}{zy}$. Inspecting the two fractions, you may realize that z must equal x . Alternatively, by applying the Bowtie again, you obtain $(y + x)(zy) = (z + y)(xy)$, and thus $zy^2 + xyz = xyz + xy^2$, meaning $zy^2 = xy^2$, or $z = x$, so the answer is choice (C).

10. B By rearranging the first two equations, you obtain $c = 7 - ab$ and $b = 5 - ac$. By substituting these relationships into the third equation, $a + (5 - ac) + (7 - ab) = 6$ is obtained. Manipulating the equation yields $a - ac - ab + 12 = 6$, or $a - a(c + b) + 6 = 0$. Since $a + b + c = 6$, $b + c = 6 - a$. Substituting this into the previous equation yields $a - a(6 - a) + 6 = a - 6a + a^2 + 6 = 0$, or $a^2 - 5a + 6 = 0$. Factoring and finding the roots gives you $a = 2$ or $a = 3$. If $a = 2$ —by substituting the value back

into the equations—then $b = 2$ and $c = 1$. If $a = 3$, then $b = 3$ and $c = 1$. You are looking for abc , and either way, the value is $2 \times 2 \times 1 = 6$. The answer is choice (B).

11. 12 You are being asked to subtract the a and b terms. Be careful that you don't just combine the largest value of a with the largest value of b to get $a - b = 9 - 2 = 7$, the wrong answer. When you combine inequalities, you have to make four calculations to check the four possibilities. Subtract the smallest values of a and b : $-4 - (-3) = -1$. Subtract the largest values of a and b : $9 - 2 = 7$. Subtract the smallest value of a and the largest value of b : $-4 - 2 = -6$. Subtract the largest value of a and the smallest value of b : $9 - (-3) = 12$. Of the four possible values above, the greatest possible value is 12.

12. C and E Try plugging in values for m and n to the inequality in the question. If $m = 5$ and $n = 1$, both numbers are integers, so choices (A) and (B) work as do all of the other choices. But what if m and n are negative decimals, say -2.3 and -6.3 ? Then choices (A) and (B) don't work, since neither number is an integer; eliminate them. Choice (C) still works. Choice (D) is out, since the sum of the two numbers is negative, but the difference is positive, leaving choice (E) in. Choices (F) and (G) also still work. However, by switching m to a positive value, such as 5, you can knock out choices (F) and (G). Only choices (C) and (E) will work no matter what numbers you plug in.

13. 35
Wouldn't this be a lot easier if you knew how many students there are? The question doesn't say, so plug in your own number. The question deals in percentages, so let's say there are 100 students in the class. That means that there are 80 boys and 20 girls, and 50 students who are 7 and 50 students who are 8. 25 percent of 20 is 5, which leaves 15 girls who are 7. Subtract 15 from 50 and you are left with 35 boys who are 7. You can also employ the group grid.

	Boys	Girls	Total
7	35	15	50
8	45	5	50
Total	80	20	100

14. A, B, and C
The lower boundary for xy is -12×6 , or -72 , and the upper boundary is $-2 \times 3 = -6$. Any values between -72 and -6 work. Be careful about choice (D): The value has to be greater than -6 , so -6 itself doesn't count.

15. 135 First solve for x : Add 2 to both sides to yield $x^2 = 0.04$, so $\frac{1}{x^2} = \frac{1}{25}$, and $x = \pm 5$. Next, add 5 to both sides of the other equation to yield $y^{1/3} = 3$, so $\sqrt[3]{y} = 3$, and $y = 27$. Since y is positive, you'll need to use the positive value of x as well, so $5 \times 27 = 135$.



Quadratic Equations

QUADRATIC EQUATIONS

You probably remember FOIL (First Outer Inner Last) from high school and you may also remember how to find the roots of an equation. On the GRE, there are really only three quadratic equation formats that you will see.

Memorize these equations:

$$(x + y)^2 = x^2 + 2xy + y^2$$

$$(x - y)^2 = x^2 - 2xy + y^2$$

$$(x + y)(x - y) = x^2 - y^2$$

Each of the above expressions has two states—the factored state and the squared state. When you see an expression in one state, rewrite it in the other state. Typically these questions will be about manipulating equations, not about solving for x . If the equations don't match one of these three formats, see if you can factor numbers or variables out of them until they do.

Naturally, the minute you see a quadratic equation, either on a quantitative comparison or a problem-solving question, if you see variables in the question and variables in the answer choices, you can always Plug In. Use your Plug In set-up for Quant Comp and plug in more than once. On problem-solving questions make sure you have labeled the terms, circled a target number, and checked all of the answer choices.

For more practice and a more in-depth look at The Princeton Review math techniques, check out our student-friendly guidebook, *Cracking the New GRE*.

DRILL 1

Question 1

Quantity A

$$(3p + 1)(3p - 1)$$

Quantity B

$$9p^2$$

- Quantity A is greater.
- Quantity B is greater.
- The two quantities are equal.
- The relationship cannot be determined from the information given.

Question 2

$$a > 0$$

Quantity A

$$(a + 2)(3a + 6)$$

Quantity B

$$(3a + 2)(a + 6)$$

- Quantity A is greater.
- Quantity B is greater.
- The two quantities are equal.
- The relationship cannot be determined from the information given.

Question 3

Quantity A

$$3^2 - 2^2$$

Quantity B

$$(3 - 2)(3 + 2)$$

- Quantity A is greater.
- Quantity B is greater.
- The two quantities are equal.
- The relationship cannot be determined from the information given.

Question 4

If $(2x + 2)^2 = 0$, then $x =$

Question 5

$$a > 0$$

Quantity A

$$(-a - 10)(10 + a)$$

Quantity B

$$10$$

- Quantity A is greater.
- Quantity B is greater.

- The two quantities are equal.
- The relationship cannot be determined from the information given.

Question 6

$$(y - 1)(y + 5) = 0$$

Quantity A

y

Quantity B

3

- Quantity A is greater.
- Quantity B is greater.
- The two quantities are equal.
- The relationship cannot be determined from the information given.

Question 7

If $m > 0$ and $3m^2 + 12m - 15 = 0$, then $m =$

Question 8

If the difference between two numbers is 4, then which of the following would be sufficient to determine the value of each of the numbers?

Indicate all possible values.

- The sum of the numbers is 4.
- The difference between the squares of the numbers is 16.
- The square of the difference between the numbers is 16.
- The sum of the squares of the numbers is greater than 8.
- Twice the greater number is 8.
- The smaller of the two numbers is less than 8.
- The product of the two numbers is 0, and neither of the numbers is negative.

Question 9

A rectangle is formed by increasing two opposite sides of a square of side length x by y units, and decreasing the two remaining sides of the square by y units. What is the area of the rectangle?

- $4x$
- $4x - 2y$
- $x^2 - 2y$
- $x^2 + 2y$
- $x^2 - y^2$

Question 10

The net profit that Ann makes from selling x pillows is given by the expression $x^2 - 2x - 288$.

The number of pillows that Ann must sell for her net profit to be zero

20

- Quantity A is greater.
- Quantity B is greater.
- The two quantities are equal.
- The relationship cannot be determined from the information given.

Question 11

What is the greatest value of x for which $(3x - 2)(x + 1) = 0$?

- 1
- $-\frac{2}{3}$
- $\frac{2}{3}$
- 1
- 2

Question 12

$$x^2 = y^2 + 1 \text{ and } y \neq 0.$$

Quantity A

$$x^4$$

Quantity B

$$y^4 + 1$$

- Quantity A is greater.
- Quantity B is greater.
- The two quantities are equal.
- The relationship cannot be determined from the information given.

DRILL 2

Question 1

The solutions of $x^2 + x - 20 = 0$ are

Indicate all possible values.

- 5
- 4
- 2
- 1
- 4
- 5
- 10
- 20

Question 2

If x is positive and y is 1 more than the square of x , then what is the value of x in terms of y ?

- $y^2 - 1$
- $y^2 + 1$
- $\sqrt{y} - 1$
- $\sqrt{y - 1}$
- $\sqrt{y + 1}$

Question 3

$$x^2 - 49 = 0$$

Quantity A

$$x^2 - 7x$$

Quantity B

$$-7x + 49$$

- Quantity A is greater.
- Quantity B is greater.
- The two quantities are equal.
- The relationship cannot be determined from the information given.

Question 4

For $x \neq -2$ and $x \neq -4$, $\frac{x}{x+4} + \frac{-3}{x+2} =$

- $\frac{x^2 - x - 12}{(x+4)(x+2)}$

$\frac{-3x}{(x+4)(x+2)}$

$\frac{x-3}{2x+6}$

$\frac{1}{x+4}$

-2

Question 5

$$a \neq -b$$

Quantity A
$$\frac{6a^2 + 12ab + 6b^2}{a + b}$$

Quantity B

$$6(a + b)$$

- Quantity A is greater.
- Quantity B is greater.
- The two quantities are equal.
- The relationship cannot be determined from the information given.

Question 6

Quantity A
$$(141)^2 - (28)^2$$

Quantity B

$$(141 - 28)^2$$

- Quantity A is greater.
- Quantity B is greater.
- The two quantities are equal.
- The relationship cannot be determined from the information given.

Question 7

$$(-x + y)(-y + x) =$$

- $x^2 - y^2$
- $y^2 - x^2$
- 0
- $-(x - y)^2$
- $(y - x)^2$

Question 8

$$x \geq 0$$

$$y \geq 0$$

$$\sqrt{x^{12}} - y$$

$$(x^3 + \sqrt{y})(x^3 - \sqrt{y})$$

- Quantity A is greater.
- Quantity B is greater.
- The two quantities are equal.
- The relationship cannot be determined from the information given.

Question 9

Quantity A

$$(s + t)^2$$

Quantity B

$$s^2 + t^2$$

- Quantity A is greater.
- Quantity B is greater.
- The two quantities are equal.
- The relationship cannot be determined from the information given.

Question 10

$$x^2 - 2xy + y^2 = 0 \text{ and } y = \frac{9}{x}$$

Quantity A

$$y$$

Quantity B

$$3$$

- Quantity A is greater.
- Quantity B is greater.
- The two quantities are equal.
- The relationship cannot be determined from the information given.

Question 11

$$\text{If } \frac{x^2 - 4x + 4}{x^2 + x - 6} = \frac{6x - 12}{x^2 + 6x + 9}, \text{ then } x =$$

Question 12

If $y = x^2 - 32x + 256$, then what is the least possible value of y ?

- 256
- 32
- 16
- 8
- 0

ANSWERS

Drill 1

1. B
2. B
3. C
4. -1
5. B
6. B
7. 1
8. A, E, G
9. E
10. B
11. C
12. A

Drill 2

1. A, E
2. D
3. C
4. A
5. C
6. A
7. D
8. C
9. D
10. D
11. 3
12. E

Drill 1

1. B Evaluate the relationship between the quantities by plugging in values for p : Try $p = 2$. Quantity A is $7 \times 5 = 35$, and Quantity B is $9 \times 4 = 36$; Quantity B is greater, so eliminate choices (A) and (C). Any value gives the same outcome, so select answer choice (B). Algebraically, you could either FOIL Quantity A or recognize the common quadratics—either way, Quantity A simplifies to $9p^2 - 1$, which is always exactly 1 less than Quantity B.
2. B Try FOILING. For Quantity A, you get $3a^2 + 6a + 6a + 12$, or $3a^2 + 12a + 12$. For Quantity B, you get $3a^2 + 18a + 2a + 12$, or $3a^2 + 20a + 12$. Remember to compare, not calculate. Notice that the only difference between the quantities is that between $20a$ and $12a$. Because a is positive, $20a$ must be greater than $12a$, thus, Quantity B will always be greater.
3. C This is one of the common quadratic equations: $(3 - 2)(3 + 2) = 3^2 - 2^2$. The answer is choice (C). If you don't recognize the common quadratic, you can just do the arithmetic and discover that $9 - 4 = (1)(5)$.
4. -1 Take the square root of both sides to begin solving this polynomial. So, $2x + 2 = 0$. Solve for x and enter in -1 as the final answer.
5. B FOIL out Quantity A to find $-10a - a^2 - 100 - 10a$, or $-a^2 - 20a - 100$. Anything other than zero to an even power is positive, so $-a^2$ is negative. A negative number minus a positive number ($20a$) will remain negative. A negative minus 100 will be even more negative. So, Quantity A must be negative, and it must be less than Quantity B. The answer is choice (B). Alternatively, plugging in a few positive values for a will give you, in the parentheses: (negative) times (positive) = negative for Quantity A, except if $a = 10$, which yields 0 for Quantity A. But Quantity A is still less than Quantity B.
6. B If $(y - 1)(y + 5) = 0$, $(y - 1) = 0$ or $(y + 5) = 0$. So, y could be 1 or -5. Thus, Quantity B is greater.
7. 1 Factor the quadratic equation: $(3m - 3)(m + 5) = 0$. Only the first factor gives a positive result: If $3m - 3 = 0$, then $m = 1$. Alternately, you may notice that the equation is true if you ignore the variables, and making $m = 1$ would allow you to disregard them.
8. A, E, and G Translate the question and answer choices into algebra. You are given that $x - y = 4$. Choice (A) tells you that $x + y = 4$, and you can solve these equations simultaneously by stacking them and adding to get $2x = 8$, $x = 4$ and $y = 0$. Choice (A) is sufficient and correct. Choice (B) tells you that $x^2 - y^2 = 16$, and can be factored: $x^2 - y^2 = (x + y)(x - y) = 16$. You are given that $(x - y) = 4$, so $(x + y)$ must also equal 4 and for that to happen, $x = 4$ and $y = 0$. Choice (B) is also sufficient and correct. Choice (C) states $(x - y)^2 = 16$. This is simply the result of squaring what you were already given and you have no way to determine what the values of x and y are, making this choice incorrect. Choices (D) and (F) are inequalities, which means there will be multiple numbers that can work with the criteria given; eliminate both choices. Choice (E) tells you that the greater number is 4. Since $x - y = 4$, that now means the smaller number must be 0, making choice (E) sufficient. Finally, choice (G) states $xy = 0$, so at least one of the numbers must be 0. Since you were also given $x - y = 4$ and that neither number is negative, this means the other number must be 4. Choice (G) is sufficient and correct.
9. E The dimensions of the new rectangle will be $x + y$ and $x - y$. To find the area of the rectangle, multiply the length by the width: $(x + y)(x - y) = x^2 - y^2$. The answer is choice (E). Or, you can just plug in values for x and y .
10. B Set the expression equal to zero and then factor it. You are looking for factors of 288 that have a difference of 2. So find the integer factor pairs, starting with 1: 1 and 288; 2 and 144; 3 and 96; 4 and 72; 6 and 48; 8 and 36; 9 and 32; 12 and 24; 16 and 18. The last pair you found works, so the factored form of your equation is: $(x - 18)(x + 16) = 0$. The solutions are 18 and -16, but obviously Ann cannot sell a negative number of pillows. The answer is choice (B).
11. C The expression on the left side of the equation will equal zero when either $(3x - 2) = 0$ or $(x + 1) = 0$. Solving these equations yields $x = \frac{2}{3}$ or $x = -1$. The question asks you for the greatest value of x , so the answer is choice (C).
12. A Plugging in 2 for y gives you $x^2 = 5$ in the given equation and 17 for Quantity B. Squaring this gives you $x^4 = 25$ for Quantity A, which is therefore larger. Plugging in any other number gives the same result. Alternatively, doing algebra by squaring both sides of the given equation reveals Quantity A: $x^4 = (y^2 + 1)(y^2 + 1) = y^4 + 2y^2 + 1$. The only difference between Quantities A and B is the $2y^2$ in Quantity A. You are told that $y \neq 0$, so $2y^2$ is always positive, and Quantity A will always therefore be larger. The answer is choice (A).

- A and E Factoring this quadratic equation gives you $(x + 5)(x - 4) = 0$. For the first solution, $x + 5 = 0$, or $x = -5$. For the second solution, $x - 4 = 0$, or $x = 4$. Alternatively, you can PITA to determine which values will satisfy the equation.
- D Plug in $x = 4$, so $y = 17$. Now plug in 17 into the answers to see which gives you 4. Only choice (D) does.
- C Remember that when a variable is squared, it yields a positive and a negative solution; hence, $x^2 - 49 = 0$ means that $x^2 = 49$ and $x = \pm 7$. If $x = 7$, then both quantities are equal to zero. If $x = -7$, then both quantities are equal to 98. The answer is choice (C).
- A Plug in $x = 2$, and the original expression turns into $\frac{2}{6} + \frac{-3}{4} = \frac{1}{3} - \frac{3}{4} = -\frac{5}{12}$, using the Bowtie. Now plug in 2 for x in the answer choices to see which equals $-\frac{5}{12}$. Only choice (A) does.
- C Whenever you see exponents, think common quadratics. If you factor the 6 out of the numerator in Quantity A, you get $6(a^2 + 2ab + b^2)$, which includes a common quadratic $(a + b)^2$. Then you can cancel $(a + b)$ from both the numerator and the denominator; Quantity A is really just $6(a + b)$. The quantities are equal.
- A Don't do the arithmetic! These are common quadratic patterns. It's not important that $x = 141$ and $y = 28$; Quantity A is $x^2 - y^2 = (x + y)(x - y)$, and Quantity B is $(x - y)(x - y)$. Since $(x - y)$ is a positive number, you can simply compare the remaining factors after it is removed from both quantities. Since x and y are positive, $(x + y)$ is greater than the remaining $(x - y)$ in Quantity B, and the answer is choice (A).
- D Factor out -1 from the parentheses on the left and rearrange the expression in the parentheses on the right to get $-1(x - y)(x - y) = -(x - y)^2$. The answer is choice (D).
- C In Quantity A, $\sqrt{x^{12}} - y = \sqrt{(x^6)^2} - y = x^6 - y$. In Quantity B, you may recognize one of the common quadratics: $(a + b)(a - b) = a^2 - b^2$. If not, FOIL; either way, Quantity B is $x^6 - y$. Thus, the two quantities are equal.
- D The best approach here is to Plug In. First, try $s = 2$ and $t = 3$: Quantity A is $(2 + 3)^2 = 5^2 = 25$, and Quantity B is $2^2 + 3^2 = 4 + 9 = 13$. Quantity A is greater, so eliminate choices (B) and (C). Next, make s and t both 0: Now Quantity A is $(0)^2 = 0$, and Quantity B is $0^2 + 0^2 = 0$. Now the two quantities are equal, so eliminate choice (A), and you're left with choice (D).
- D Factor the quadratic expression to get $(x - y)(x - y) = 0$; $x - y$ must equal 0, so you know that $x = y$. Thus, $y = \frac{9}{y}$, $y^2 = 9$, and $y = 3$ —eliminate choices (A) and (B)—or -3 —eliminate choice (C). The answer is choice (D).
- 3 To solve this question, factor everything to its simplest form: $x^2 - 4x + 4$ factors to $(x - 2)(x - 2)$; $x^2 + 6x + 9$ factors to $(x + 3)(x + 3)$; $x^2 + x - 6$ factors to $(x - 2)(x + 3)$; and, finally, $6x - 12$ factors to $6(x - 2)$. Thus, $\frac{x^2 - 4x + 4}{x^2 + x - 6} = \frac{6x - 12}{x^2 + 6x + 9}$ factors to $\frac{(x - 2)(x - 2)}{(x - 2)(x + 3)} = \frac{6(x - 2)}{(x + 3)(x + 3)}$. Cancel $(x - 2)$ from the numerator and denominator on the left-hand side of the equation to yield $\frac{(x - 2)}{(x + 3)} = \frac{6(x - 2)}{(x + 3)(x + 3)}$. Next, multiply both sides by $(x + 3)$ to yield $(x - 2) = \frac{6(x - 2)}{(x + 3)}$, and divide both sides by $(x - 2)$ to yield $1 = \frac{6}{(x + 3)}$. Finally, multiply both sides by $(x + 3)$ again or turn 1 into a fraction and cross-multiply; either way, you're left with $6 = x + 3$, so $x = 3$.
- E First, factor the quadratic equation: $x^2 - 32x + 256 = (x - 16)^2$. Any quantity squared is either positive or zero. To minimize the expression $(x - 16)^2$ and the value of y , let $x = 16$, so that $y = 0$. The answer is choice (E).

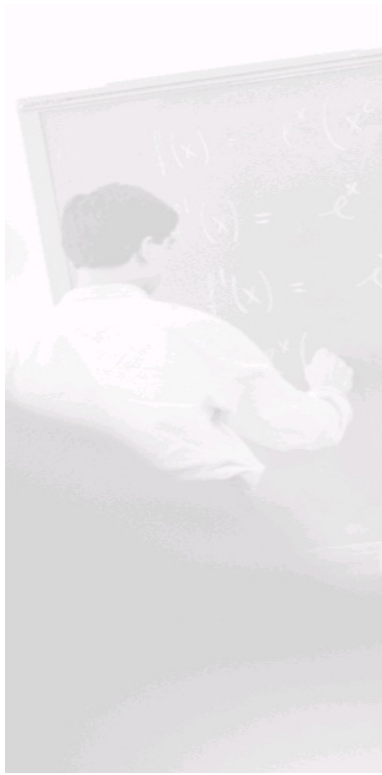

Probability, Rates, and Statistics

PROBABILITY, RATES, AND STATISTICS

The key to mastering these kinds of arithmetic questions is to learn simple, effective ways to organize your information. ETS will always give you just enough information to figure out the one piece that is missing. A good set-up will help you fill in the missing pieces quickly and easily.

Once you understand how the set-ups work, you need only train yourself to recognize the opportunity and use them. Think of words such as average and probability as triggers that provoke a very specific action. Sensitize yourself to these words and once you see them, before you've even finished reading the question, start making your set-up.

MEAN

Known to ETS as arithmetic mean and to the rest of us as average, these problems can be time-consuming if you don't know what you're doing, but will unravel easily when you do. For example, to find the average of five, seven, and nine, add the three numbers together and divide by three. Thus, averages consist of three parts, the average, the number of things, and the total. The minute you see the word average in a problem, draw your pie.

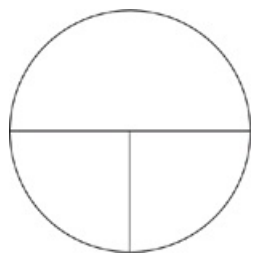

When you see the word AVERAGE make a pie on your scratch paper. If you see the word AVERAGE again, make another pie.

If ETS were to give a list of numbers and ask for the average, it would be too easy. While ETS will always give you two out of the three pieces, they probably won't be the pieces you expect. It may give you the average and the total and ask for the number of things, or it may give the average and the number of things and ask for the total.

Fill in the information you have.

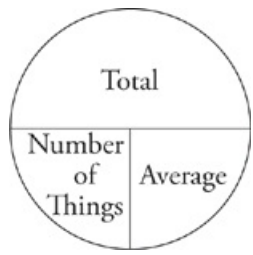

If you have the number of things and the total, you will divide to get the average. If you have the average and the total, you will divide to get the number of things. If you have the number of things and the average, simply multiply to get the total.

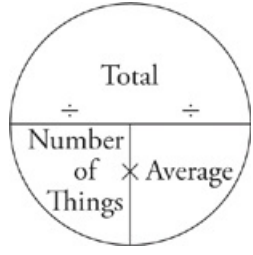

If asked to find the average of five, seven, and nine, your scratch paper would look like the image shown below.

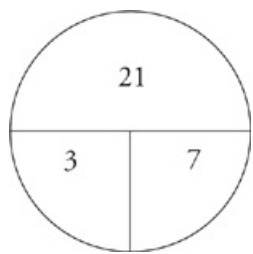

Of course, it's not usually quite that simple. ETS may give you the average of one group, the total of a second, and then ask for the average of both combined. Just make sure that you draw a new pie every time you see the word average. Work the problem through in bite-sized pieces, read with your finger, and make sure your hand is moving on the scratch paper.

RATE

Rate problems work the same way that average problems do. In fact, you can use the same method to organize your information.

This is what a Rate Pie looks like.

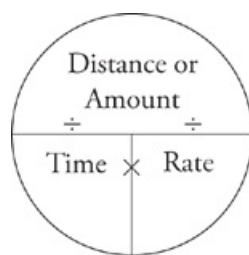

The first thing you do when you see a rate problem is to make your Rate Pie. ETS will always give you two of the three pieces of information. You will have to find the third. If you're asked for time, divide the distance or amount by the rate. If you're asked for rate, divide the distance or amount by the time, and if you're asked for distance or amount, multiply the time by the rate. Make sure to keep an eye on your units. You may be given a rate in miles per hour but asked for a number of minutes.

The way to prevent units errors is to use your scratch paper and label everything.

MEDIAN

When you see the word median, find a group of numbers and put them in order. Median, like the median on a highway, simply means the number in the middle. It's not a difficult concept, so there are only two ways ETS can try to mess you up. The most common trick is to give you numbers out of order. Your first step must always be to put the numbers in order on your scratch paper.

When you see the word MEDIAN, find a group of numbers and put them in order.

The second trick they may try is to give you an even number of numbers. In this case, the median will be the average of the two numbers in the middle. In the case of 2, 2, 3, 4, 5, 5, 5, 6, 7, 7, 120, 345, 607, the median is 5. In the case of 2, 2, 3, 4, 5, 5, 5, 6, 7, 7, 120, 345, 607, 1250, the median is 5.5.

MODE AND RANGE

Mode means the number that comes up most often. The mode of the set {4, 6, 6, 13, 14, 21} is six. The range is the difference between the highest number and the lowest. In this case it is 17, or $21 - 4$. Rarely will you see a problem testing mode by itself. It is more likely to come up in connection with mean, median, and/or standard deviation.

STANDARD DEVIATION

There are not a lot of standard deviation questions in the question pool, so they don't come up that often. However, because they might come up, you need to know how to handle them. But don't worry, on the GRE, ETS sticks to the basics. You will never need to know how to calculate standard deviation. You will only be asked about percentages of people or things that fall a few standard deviations from the norm.

Imagine you measured the weight of all apples picked at Orchard X. Suppose the average weight of an apple is 6 ounces. As you can imagine, the vast majority of those apples will weigh somewhere close to 6 ounces. A much smaller number will be about 7.5 ounces, and you may even get a few that are heavier than eight ounces. The weight of these apples is likely to follow a normal distribution, which means that if you graphed the number of apples at each weight on a bar graph, you would end up with a bell curve.

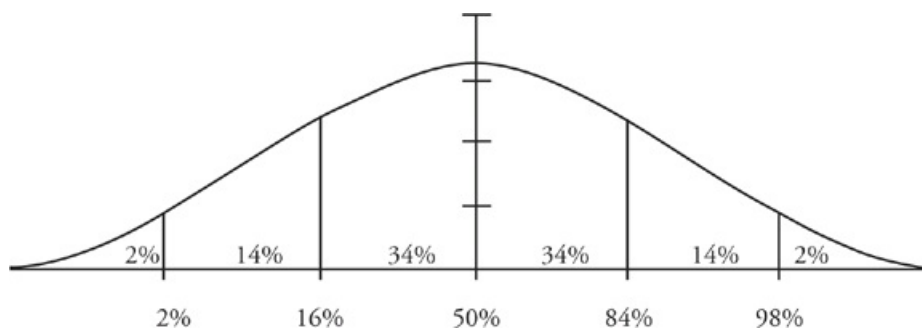

This chart is the bell curve. It will never change. Memorize the numbers 34, 14, and 2.

On this curve, the mean, the median, and the mode are all the same. It makes sense, right? The average weight of our apples is 7.5 ounces, the most common weight and falls in the middle of the pack. If the apples have a standard deviation of 1.25 ounces, 34 percent of the apples picked in the orchard weigh between 6 and 7.25 ounces, 14 percent weigh between 7.25 and 8.5, and only 2 percent weigh more than 8.5 ounces. As you move from one percentage group to another you are moving one standard deviation from the norm. If you're asked "What percentage of apples weighs more or less than two standard deviations from the norm?" the answer will be 4 percent.

PROBABILITY

Probability, on the GRE, can be defined as $\frac{\text{the \# of things you want}}{\text{the \# of things you could get}}$. It's a fraction and the number of things you could get is the total. The minute you see the word probability, make your divisor line and find your total. Once you've done this, you are already half way to the answer.

The minute you see the word PROBABILITY, make your divisor line on your scratch paper and find your total.

One Event

Imagine you have a sock drawer that has 12 blue socks and 8 green socks. What is the probability that, when you reach into the drawer, you get a blue sock? Make your divisor and find your total. On the bottom you have 20 because there 20 socks you could get. On top you have 12 because there are twelve socks (blue) that you want. The probability is $\frac{12}{20}$ or $\frac{3}{5}$. The probability of getting a green sock is $\frac{8}{20}$ or $\frac{2}{5}$. The probability of getting any sock is 20 things you want over 20 things you could get, or 1. The probability of getting a ham and cheese sandwich is, we hope, 0 ($\frac{0 \text{ things you want}}{20 \text{ things you could get}}$). It is important to note that probability is always between 1 and 0. The chance that something will happen added to the chance that it won't happen will always add up to 1.

Two Events

If two events are to occur, the probability of them both happening is equal to the probability of the first happening multiplied by the probability of the second happening. This makes sense because a fraction times a fraction equals a smaller fraction. If you have a very low probability of one event occurring and a very low probability of a second event happening, the odds of them both happening will be even lower. The probability of getting a green sock in the drawer above is $\frac{2}{5}$. The probability of getting a green sock the second time is $\frac{7}{19}$ because there are seven green socks left, after you've removed the first one, and 19 socks left in the drawer. The probability of getting a green sock both times is $\frac{2}{5} \times \frac{7}{19}$, or $\frac{14}{95}$.

One of Two Events

Imagine you now have five purple socks in your drawer. If you are asked to find the probability of getting a purple OR a green sock, you have to add the probabilities. With 12 blue socks, eight green socks, and five purple socks, your new total is 25. You have an $\frac{8}{25}$ chance of getting a green sock and a $\frac{5}{25}$ chance of getting a purple one. The chance of getting one or the other is $\frac{5}{25} + \frac{8}{25}$ or $\frac{13}{25}$.

At Least One Event

The one last wrinkle to look at is what happens if you are asked to find the probability of at least one event happening. When rolling dice, for example, what is the probability that you roll 1 at least once out of three rolls? This will get complicated because at least one means that the event could occur once, twice, or even three times. That's more calculating than you want to do. Instead, when asked to find at least one, find the probability that none will occur and subtract it from 1. This will leave you with at least one. In this case, the chances of not rolling a one on the first roll are $\frac{5}{6}$. The chances on the second and third rolls are the same. Therefore the chances of not rolling a one go down with each additional roll, but only by a little bit because you have a very strong possibility that it will not happen. The chances that you will not roll a 1 in your first three rolls are $\frac{5}{6} \times \frac{5}{6} \times \frac{5}{6}$, or $\frac{125}{216}$. The chances that you will roll at least one 1, therefore are $\frac{91}{216}$ ($216 - 125 = 91$).

DRILL 1

Question 1

In terms of y , what is the average (arithmetic mean) of $4y$ and 22 ?

- $4y + 22$
- $4y + 11$
- $4y - 22$
- $2y + 11$
- $2y + 22$

Question 2

Quantity A

The average (arithmetic mean) of 14, 22, and 48

- Quantity A is greater.
- Quantity B is greater.
- The two quantities are equal.
- The relationship cannot be determined from the information given.

Quantity B

The average (arithmetic mean) of 12, 22, and 50

Question 3

2, 3, 5, 7

Quantity A

The average (arithmetic mean) of the numbers above

- Quantity A is greater.
- Quantity B is greater.
- The two quantities are equal.
- The relationship cannot be determined from the information given.

Quantity B

The median of the numbers above

Question 4

Susan travels by car at an average speed of 50 miles per hour for 4 hours and then at an average speed of 20 miles per hour for 2 hours. What is her average speed, in miles per hour, for the entire 6-hour trip?

- 25
- 30
- 35
- 40
- 45

Question 5

www.ztcprep.com
 12 white t-shirts, 4 blue t-shirts, and 5 red t-shirts.

The probability that Liz randomly selects a blue t-shirt

$$\frac{2}{5}$$

- Quantity A is greater.
- Quantity B is greater.
- The two quantities are equal.
- The relationship cannot be determined from the information given.

Question 6

Quantity A

Quantity B

The average (arithmetic mean) of 4 numbers, each less than 6 and greater than 5

The median of 6 numbers, each less than 5 and greater than 4

- Quantity A is greater.
- Quantity B is greater.
- The two quantities are equal.
- The relationship cannot be determined from the information given.

Question 7

For which of the following values of x is the mode of $2x$, $x + 5$, $3x - 2$, $5x - 7$, and $4x$ equal to 4 ?

- 2
- 3
- 4
- 5
- 7

Question 8

A hat contains 18 raffle tickets, numbered 1 through 18. If two raffle tickets are chosen at random from the hat, what is the probability that both tickets are even numbers?

- $\frac{2}{9}$
- $\frac{4}{17}$
- $\frac{1}{4}$
- $\frac{1}{2}$
- $\frac{33}{34}$

Question 9

Quantity A

The time it takes to read k words at j words per minute

Quantity B

The time it takes to read $(k + 10)$ words at $(j + 10)$ words per minute

- Quantity A is greater.
- Quantity B is greater.
- The two quantities are equal.
- The relationship cannot be determined from the information given.

Question 10

How many committees of 5 members can be chosen from a group of 8 people?

- 28
- 56
- 118
- 336
- 6,720

Question 11

The average (arithmetic mean) number of passengers on a subway car is 60. If the number of passengers on a car has a normal distribution with a standard deviation of 20, approximately what percent of subway cars carry more than 80 passengers?

- 16%
- 48%
- 68%
- 88%
- 98%

Question 12

If the average of 10, 12, n , and n is greater than 25, what is the least possible value of integer n ?

- 38
- 39
- 40
- 41
- 42

DRILL 2

Question 1

$$x, x^2, x^y, x^{y-1}, x^4, x^6$$

$$x > 1$$

Quantity A

The mode of the numbers above when $y = 4$

Quantity B

The median of the numbers above when $y = 5$

- Quantity A is greater.
- Quantity B is greater.
- The two quantities are equal.
- The relationship cannot be determined from the information given.

Question 2

Trip A is $6x$ miles long and takes $5y$ hours. Trip B is $5x$ miles long and takes $4y$ hours.

Quantity A

The rate of trip A in miles per hour

Quantity B

The rate of trip B in miles per hour

- Quantity A is greater.
- Quantity B is greater.
- The two quantities are equal.
- The relationship cannot be determined from the information given.

Question 3

If the probability that the first event will occur is $\frac{1}{4}$, and the probability that the second event will occur is $\frac{1}{\sqrt{x+2}}$, then what is the probability that both events will occur?

- $\frac{\sqrt{x+2}}{4x+8}$
- $\frac{\sqrt{x+2}}{4}$
- $\frac{\sqrt{x+2}}{16x+32}$
- $\frac{4}{\sqrt{x+2}}$
- $4\sqrt{x+2}$

Question 4

Five numbers in a set are arranged from least to greatest. If the median of the first two numbers is 13 and the average (arithmetic mean) of the remaining numbers is 23, what is the average (arithmetic mean) of the entire set?

A bag contains 12 marbles: 5 of the marbles are red, 3 are green, and the rest are blue.

Quantity A

The probability of consecutively choosing two red marbles and a green marble without replacement

Quantity B

The probability of consecutively choosing a red and two blue marbles with replacement

- Quantity A is greater.
- Quantity B is greater.
- The two quantities are equal.
- The relationship cannot be determined from the information given.

Question 6

If the average (arithmetic mean) of 31, 41, and p is between 29 and 47, inclusive, what is the least possible value of $(p - 7)^2 =$

Question 7

Water flows into a 25-liter bucket through a hose and out through a hole in the bottom of the bucket. The rate of flow through the hose is 1 liter per minute. If the bucket is filled to capacity in 40 minutes, at what rate, in liters per minute, was water flowing out of the bucket through the hole?

- $\frac{3}{8}$
- $\frac{3}{5}$
- $\frac{5}{8}$
- $\frac{8}{5}$
- $\frac{13}{8}$

Question 8

A pair of dice is tossed twice. What is the probability that the first toss gives a total of either 7 or 11 and the second toss gives a total of 7?

- $\frac{1}{27}$
- $\frac{1}{18}$
- $\frac{1}{9}$
- $\frac{1}{6}$
- $\frac{7}{18}$

A photocopier can copy r pages per hour. How many pages can it copy in s seconds?

- $\frac{rs}{60}$
- $\frac{r}{60s}$
- $\frac{s}{3,600r}$
- $\frac{rs}{3,600}$
- $3,600rs$

Question 10

Quantity A

The average (arithmetic mean) cost per hinge for 16 hinges that cost a total of $2p$ cents

Quantity B

The average (arithmetic mean) cost per hinge for 4 hinges that cost a total of $\frac{p}{2}$ cents

- Quantity A is greater.
- Quantity B is greater.
- The two quantities are equal.
- The relationship cannot be determined from the information given.

Question 11

In both rural and urban areas of country G, the average annual number of holidays taken by citizens is 8, and the annual number of holidays follows a normal distribution. In rural areas, 2% of the citizens take more than 12 holidays per year. In urban areas, 2% of the citizens take more than 16 holidays per year. How much greater is the standard deviation of the annual number of holidays taken by urban citizens than that of rural citizens?

Question 12

Three dice are rolled simultaneously. What is the probability that exactly two of the dice will come up as the same number?

- $\frac{5}{12}$
- $\frac{11}{24}$
- $\frac{25}{54}$
- $\frac{13}{27}$
- $\frac{1}{2}$

DRILL 3

Question 1

There are 32 students in Jamie's eighth-grade class. Each student took a 50-point test; the class average (arithmetic mean) was 82% correct. The teacher has assigned one 4-point, extra-credit question. How many students will need to answer the extra-credit question correctly in order to bring the class average to 86% correct?

- 15
- 16
- 17
- All of the students
- It will not be possible for the class to reach an average of 86% correct.

Question 2

Vinay and Phil are driving in separate cars to Los Angeles, both leaving from the same place and traveling along the same route. If Vinay leaves at 1 a.m. and travels at 40 miles per hour, and Phil leaves at 5 a.m. and travels at 50 miles per hour, at what time does Phil catch up to Vinay?

- 1 p.m.
- 5 p.m.
- 7 p.m.
- 9 p.m.
- 11 p.m.

Question 3

A set of six numbers consists of x , $x + 3$, $x + 5$, $x + 7$, $x + 11$, and $x + 13$. What is the median of this set, in terms of x ?

- $x + 5$
- $x + 6$
- $x + 6.5$
- $3x + 8$
- $6x + 39$

Question 4

Damon rolls three six-sided dice. What is the probability that his total will be greater than 16 ?

Question 5

John will spend the summer in one of the houses either on Surf Street or Breaker Way. Surf Street has 1 landside house and 4 beachside houses, and Breaker Way has 1 beachside house and 2 landside houses. A sea turtle randomly lays eggs in front of a beachside house on Surf Street, and another sea turtle randomly lays eggs in front of a beachside house on Breaker Way. What are the probabilities that a sea turtle lays its eggs in front of John's house, depending on which street he lives on?

- $\frac{4}{25}$

$\frac{4}{15}$

$\frac{1}{3}$

$\frac{17}{15}$

Question 6

If x equals all prime numbers that satisfy the inequality

$$\frac{1}{|10-x|} \leq \frac{5}{x^2}$$

what is the average value of x ?

Question 7

Set A: $\{-7, -4, -1, 0, 5, 8, 10, 10, 13, 21\}$

In Set A above, if positive integer x is subtracted from the 3 largest numbers in the list and x is added to the 3 smallest even numbers in the list, which of the following will be true ?

- The average of the set will increase by x.
- The average of the set will decrease by x.
- The average of the set will stay the same.
- There will be no mode in the new set.
- The standard deviation of the set will stay the same.
- The median of the set will stay the same.
- The median of the set will increase by x.

Question 8

Alejandra took five Spanish quizzes and scored a total of 227 points. Nigel took the same quizzes and scored a total of 189. What is the difference between Alejandra's average score and Nigel's average score?

Question 9

Which of the following could be the median for a set of integers $\{97, 98, 56, x, 86\}$, given that $20 < x < 80$?

- 71
- 86
- 91.5
- 97
- 397.5

Question 10

There are 40 marbles in a jar. If $\frac{1}{5}$ of the marbles are blue, $\frac{1}{4}$ of the remaining marbles are red, and 10 marbles are green. If a marble

is selected at random, then what is the probability that the marble will not be blue, red, or green?

Question 11

During a sales contest at a local electronics store, 65 employees sold a total of \$91,000 worth of merchandise. If the standard deviation of sales among those employees was \$130 and the sales were normally distributed, what percentage of employees sold \$1270 or more worth of merchandise?

- 28%
- 50%
- 65%
- 84%
- 98%

Question 12

On the most recent test in stats class, Jamal scored x points and Raya scored 73 points. If the average of Cliff and Raya's scores is 79 points, and the average of Jamal and Cliff's scores is 89, then $x =$

DRILL 4

Question 1

After preparing the results of their measurement of the weight of children that participated in their pediatric study, Steph's graduate assistant spilled coffee on their papers. If Steph is able to read that 50 lbs is the third standard deviation to the left of the mean, and 110 lbs also falls on a standard deviation, then which of the following could be the mean weight of the children in the study, assuming regular distribution?

Indicate all possible values.

- 80
- 85
- 86
- 95
- 100

Question 2

Jeff and Ali race each other at the Tentleytown Speedway. Ali's car travels at 300 feet per second, and Jeff's car travels at 250 feet per second. If one lap around the track is 3000 feet long, and each car travels at a constant rate, how many laps will it take Ali to overtake Jeff?

- 1
- 5
- 6
- 10
- 60

Question 3

Helen and Sergey must cut down a row of trees. Helen can cut down the entire row in 3 hours, and Sergey can cut down the entire row in 7 hours. If they simultaneously start cutting trees, each starting at one end of the row and working towards each other, what fraction of the trees will Sergey have cut at the time they meet?

Question 4

In a set of five consecutive integers, which of the following must change the average of the set without changing its median ?

- Multiplying each of the numbers in the set by 6.
- Adding 10 to each of the numbers in the set.
- Subtracting 3.5 from each of the numbers in the set.
- Adding 8.2 to the 2 largest numbers and subtracting 8.2 from the 3 smallest numbers in the set.
- Adding .5 to the 2 largest and to the 2 smallest numbers in the set.
- Dividing each of the numbers in the set by 2.
- It's not possible to change the average of the set without changing its median.

Question 5

Paul is able to grade 10 essays every half hour, and Sarah is able to grade 8 essays every hour. If Paul and Sarah work together grading

essays for h hours, then in terms of p , s , and h , how many essays will they grade?

Indicate all such amounts.

- $\frac{p + s}{h}$
- $\frac{2p + s}{h}$
- $h(p + s)$
- $2h(p + s)$
- $h(2p + s)$
- $h(p + 2s)$
- $2hp + hs$

Question 6

If the average of 5 numbers is 36 and the average of four of those numbers is 34, then what is the value of the fifth number?

- 2
- 34
- 35
- 36
- 44

Question 7

Noah's contracting company builds road at a rate of 1 mile per week, except during the rainy season, when that rate drops to $\frac{1}{2}$ mile per week. If Noah is hired to build 11 miles of road, and his company begins construction 5 weeks before the start of the rainy season, how many weeks will it take Noah's company to complete the contract? (Rainy season lasts 14 weeks.)

Question 8

Three factory employees work at constant rates to produce DVDs. Employee A produces y DVDs in $\frac{2}{5}$ of an hour. Employee B produces y DVDs in $\frac{3}{5}$ of an hour. Employee C produces y DVDs in $\frac{5}{4}$ of an hour. Which of the following combinations of employees can produce at least $5y$ DVDs in 2 hours?

Indicate all such statements.

- Employee A alone
- Employee B alone
- Employee C alone
- Employees A and B together
- Employees B and C together
- Employees A, B, and C together

- Even if all three employees work together, they will not finish the job

Question 9

Two cyclists, A and B, are 145 miles apart on a straight road. At 1:30 p.m., cyclist A begins riding at a constant speed of 20 miles per hour toward cyclist B. At 2:00 p.m., cyclist B begins riding toward cyclist A at a constant speed. At 5:00 p.m. they meet. How fast, in miles per hour, was cyclist B riding?

Question 10

Portia rates all her first dates as either “duds” or “dudes.” Her date on Wednesday night was a dud. On the next night, she went on a date with someone else who was also a dud. If the probability of her getting two duds in a row was $\frac{4}{25}$, what is the probability that her next date will be a dude ?

- $\frac{1}{5}$
- $\frac{9}{25}$
- $\frac{2}{5}$
- $\frac{3}{5}$
- $\frac{21}{25}$

Question 11

Victor is walking at a rate of 1 mile every 17 minutes. Sarah is walking at a rate of 1 mile every 14 minutes. If they are 10 miles apart and are approaching each other along a straight road, how many hours will it take them to meet, rounded to the nearest hundredth?

ANSWERS

Drill 1

1. D
2. C
3. A
4. D
5. B
6. A
7. A
8. B
9. A
10. B
11. A
12. C

Drill 2

1. C
2. B
3. A
4. 19
5. B
6. 64
7. A
8. A
9. D
10. C
11. 2
12. A

Drill 3

1. B
2. D
3. B
4. $\frac{1}{54}$ (or any equivalent fraction)
5. B, D
6. $\frac{10}{3}$
7. C
8. 7.6
9. B
10. $\frac{14}{40}$
11. D
12. 93

Drill 4

1. A, C, D
2. B
3. $\frac{3}{10}$ or 0.3
4. E
5. E, G
6. E
7. 17
8. A, D, F
9. 25
10. D
11. 1.28

Drill 1

- D To find the average, add up the values and divide by 2: $\frac{4y+22}{2} = \frac{2(2y+11)}{2} = 2y+11$. You can also Plug In on this one. If $y = 3$, then $\frac{4(3)+22}{2} = 17$, your target number. Only choice (D) hits the target.
- C The average is the sum divided by the number of items. Both ask for the average of three numbers. The sum of the three numbers in both quantities is 84, so their averages must be equal.
- A The mean is found by dividing the sum of the elements by the number of elements. In this case: $2 + 3 + 5 + 7 = 17$, and $17 \div 4 = 4.25$, the mean. The median is the middle number, or, if the list contains an even number of elements, the average of the middle two elements (when they are arranged in increasing order). In this case, the average of 3 and 5 is 4. Quantity A is greater than Quantity B.
- D Use the given averages to figure out Susan's total distance: 4 hours at an average speed of 50 miles per hour is a total of 200 miles, and 2 hours at an average speed of 20 miles per hour is a total of 40 miles. Susan goes a total of 240 miles in 6 hours, thus, her average speed is $\frac{240 \text{ miles}}{6 \text{ hours}}$, or 40 miles per hour. The answer is choice (D).
- B To calculate the probability, divide the part by the whole: $\frac{\text{blue shirts}}{\text{total shirts}} = \frac{4}{11}$. Choice (B) is correct because $\frac{4}{11} < \frac{4}{10}$ (which is simply $\frac{2}{5}$ multiplied by 2).
- A Although you can't find an exact value for either quantity, you can find a possible range for each. In Quantity A, if all 4 numbers are between 5 and 6, then their average is, too. Similarly, in Quantity B, if all 6 numbers are between 4 and 5, then so is their median. Any number between 5 and 6 is greater than any number between 4 and 5, so Quantity A is greater.
- A Remember that mode means the number that appears "most often." Plug In the Answers. For choice (C), if $x = 4$, then the numbers become: 8, 9, 10, 13, 16. For a list of numbers to have a mode, there has to be at least two of one of the numbers. So this list has no mode; eliminate choice (C). For choice (A), if $x = 2$, then the numbers become: 4, 7, 4, 3, 8. Because 4 appears twice, 4 is the mode—the answer is choice (A).
- B Think of this problem as if you're pulling out an even ticket and then another even ticket. So, for the first ticket there are 9 possible evens out of 18 total, so the probability that the first ticket is even is $\frac{9}{18}$. Now you have one fewer even ticket in the hat. So there are 8 evens out of 17 total tickets for the second ticket, thus, the probability is $\frac{8}{17}$. You want an even AND an even, so multiply: $\frac{9}{18} \times \frac{8}{17} = \frac{4}{17}$. The answer is choice (B).
- A Plug in numbers and use the rate formula—amount = rate \times time—to check the quantities. If $j = 1$ and $k = 2$, then Quantity A is 2 minutes and Quantity B is $\frac{20}{11}$ minutes. Quantity A is greater, so eliminate choices (B) and (C). Any acceptable set of values gives the same outcome; select choice (A).
- B This is the number of combinations of 8 items taken 5 at a time (because the order does not matter). This number is equal to $\frac{8 \times 7 \times 6 \times 5 \times 4}{5 \times 4 \times 3 \times 2 \times 1} = 8 \times 7 = 56$.
- A Adding the standard deviation (20) to the mean (60) gives you the number of passengers in a car that carries exactly one standard deviation above the mean number of passengers (80). The first standard deviation above the mean represents 34% of the population in a normal distribution, and a further 50% falls below the mean, so 84% of the cars will carry 80 people or fewer. Subtracting this from the entire population (100%) gives you the percent of cars that carry greater than 80: $100\% - 84\% = 16\%$. The answer is choice (A).

12. C To find the average, divide the total by the number of values. So, $\frac{10+12+n+n}{4} > 25$. Multiply both sides of the inequality by 4 and then subtract 22 (10 + 12) to find $2n > 78$. Divide by 2 to find $n > 39$. So, n is NOT 39; it is the least integer greater than 39, which is 40. Alternatively, you could plug in the answers starting with choice (A) because the question asks for the least possible value. If n = 38 or 39, then the average is not greater than 25. If n = 40, the average is greater than 25. The answer is choice (C).

1. C In Quantity A, if $y = 4$, then the numbers (arranged in increasing order) become $x, x^2, x^3, x^4, x^4, x^6$; the mode is x^4 . In Quantity B, if $y = 5$, then the numbers become $x, x^2, x^4, x^4, x^5, x^6$. Usually, you'd need to take the average of the middle two numbers to find the median because there is an even number of values, but in this case they're both x^4 . The median, then, is x^4 , so the quantities are equal. Because $x > 1$, you don't have to worry about special cases such as 0, 1, negatives, or fractions, and the correct answer is choice (C).
2. B Rate is calculated by dividing the distance traveled by the time elapsed. Plug In to compare the two rates. If you plug in $x = 4$ and $y = 2$, the rate for trip A will be: $\frac{6(4)}{5(2)} = \frac{24}{10} = 2.4$ mph and the rate for trip B will be: $\frac{5(4)}{4(2)} = \frac{20}{8} = 2.5$ mph; eliminate choices (A) and (C). Any set of values will have a greater rate for trip B, so select choice (B).
3. A Plug In to make this problem much simpler. If you plug in $x = 2$, then the probability for the second event is: $\frac{1}{\sqrt{4}} = \frac{1}{2}$. Now, because this is an "and" probability problem, you multiply the two probabilities together to find the target answer: $\frac{1}{4} \times \frac{1}{2} = \frac{1}{8}$. Choice (A) is the only one that works: $\frac{\sqrt{2+2}}{4(2)+8} = \frac{2}{16} = \frac{1}{8}$.
4. 19 Take the problem a piece at a time. If a set has only two numbers, the median is the average of those two numbers. Set up average wheels for each of the first two averages. For the first one, two numbers that average 13 total to 26. For the second average, three numbers that average 23, so the must have a total of 69. Set up one final average wheel for all five numbers: 5 numbers total 95. Solve for the average, and you should get 19 from $95 \div 5$.
5. B Quantity A asks for the probability "without replacement," so that means you have to take into account that there will be one marble less in the total after each draw. The probability of first choosing a red marble is $\frac{5}{12}$, a second red marble is $\frac{4}{11}$, and then a green marble is $\frac{3}{10}$. This is an "and" probability problem, so you have to multiply the probability of each event together: $\frac{5}{12} \times \frac{4}{11} \times \frac{3}{10} = \frac{60}{1320} = \frac{1}{22}$. For Quantity B, you do the same thing, but the total stays the same for each draw: $\frac{5}{12} \times \frac{4}{12} \times \frac{4}{12} = \frac{80}{1728} = \frac{5}{108}$. Quantity B is greater.
6. 64 To find the least possible value of p , work with the lowest possible average, 29. Draw an Average Pie. You have 3 values with an average of 29, so your total is $3 \times 29 = 87$. Now you know that $31 + 41 + p = 87$, so $p = 15$, and $(p - 7)^2 = 64$.
7. A Remember that amount = rate \times time. So, 25 liters = rate \times 40 minutes. The rate was $\frac{25 \text{ liters}}{40 \text{ minutes}} = \frac{5}{8}$ liters/min. The net rate at which the bucket is filling is the difference between the hose's rate and the leaking rate. So, $(1 \text{ liter/min}) - (\text{leaking rate}) = \frac{5}{8}$. Solve for the leaking rate to find the leaking rate is $\frac{3}{8}$ liters/min; the answer is choice (A).
8. A There are a total of $6^2 = 36$ possibilities for each toss. There are a total of 8 ways we can get a total of 7 or 11 on the first toss: 6 ways to get a total of 7—(1, 6), (2, 5), (3, 4), (4, 3), (5, 2), or (6, 1)—plus 2 ways to get a total of 11—(5, 6) or (6, 5). Therefore, the probability of getting a total of either 7 or 11 on the first toss is $\frac{8}{36} = \frac{2}{9}$. The probability of getting a total of 7 on the second toss is $\frac{6}{36} = \frac{1}{6}$ so the probability that both of these independent events occur is the product $\frac{2}{9} \times \frac{1}{6} = \frac{1}{27}$, choice (A).
9. D Try plugging in a number for s that divides easily by 60, such as 7,200. So, if $s = 7,200$ seconds, that's 120 minutes or 2 hours. Plug in a nice number for r such as 5. So, if the copier makes 5 pages per hour for 2 hours, your target is 10 pages. Plug $s = 7,200$ and $r = 5$ into the answers. Ballpark: Choice (A) is too large, choice (B) too small, choice (C) too small, and choice (E) far too large. Only choice (D) yields your target of 10.
10. C Plug in a value for p . Try $p = 16$: In Quantity A, then 16 hinges cost a total of 32 cents, for an average cost of 2 cents per hinge; in Quantity B, 4 hinges cost a total of 8 cents, for, again, an average cost of 2 cents per hinge. The quantities are equal, so eliminate choices (A) and (B). Any value for p will yield the same results: The quantities will always equal; the answer is choice (C).

11. 2 Draw two bell curves: one for rural areas, and one for urban areas. The three standard deviations above the mean each represent 24%, 14% and 2% of the population, respectively. The mean in both cases is 8. In rural areas, 2% of the citizens take more than 12 holidays a year, so 12 is two standard deviations above 8; the standard deviation is thus the difference between 8 and 12 divided by 2, or 2. In urban areas, similarly, the standard deviation is $16 - 8$ divided by 2, or 4. The difference between the two standard deviations is thus $4 - 2 = 2$.
12. A There are a total of $6^3 = 216$ total possible rolls for the three dice. First figure out the probability of getting exactly two 1's. There are $5 \times 3 = 15$ ways this could happen: 112, 113, 114, 115, 116; 121, 131, 141, 151, 161; or 211, 311, 411, 511, 611. You could repeat this list of 15 possibilities in the obvious way for exactly two 2's, exactly two 3's, and so on. Thus, the total number of favorable rolls is $6 \times 15 = 90$. Because there are 216 possible rolls, 90 of which are favorable, the probability of getting exactly two of the three dice to show the same number is $\frac{90}{216} = \frac{5}{12}$, choice (A).

1. 1 If the class average is 82% on a 50-point test, the average score was 41 points out of 50. Use the Average Pie to find the sum of the class's scores: $(41)(32) = 1,312$. To reach a class average of 86%, each student will need to average 43 points out of 50 points. Use the Average Pie to find the desired sum of the class's scores: $(43)(32) = 1,376$. The difference is $1,376 - 1,312 = 64$, so the class needs to make up 64 points; $\frac{64}{4} = 16$, so 16 students need to answer the extra credit question correctly. The answer is (B).
 Alternatively, notice that the class's average needs to increase by 4%, or 2 points on average for a 50-question test. But the extra credit is worth 4 points, so to average half of a 4-point increase, only half the students (16) need to get the extra credit correct.
2. D Before Phil leaves, Vinay has traveled for 4 hours; the rate formula is distance = rate \times time, so Vinay has gone 40 miles per hour \times 4 hours = 160 miles. Upon leaving, Phil is gaining on Vinay at a rate of 10 miles per hour, because he travels 10 more miles per hour than Vinay. Now your equation is 160 miles = 10 miles per hour \times time, so time = 16 hours. Phil left at 5 a.m., so he'll catch up to Vinay at 9 p.m., so the answer is choice (D).
3. 3 Since there are variables in the answer choices, try plugging in 2 for x. Your two middle numbers are now 7 and 9, and the median is their average, 8. Circle 8 as your target answer. After you check all the choices, only choice (B) matches.
4. $\frac{1}{54}$ (or any equivalent fraction) First, figure out how many different results that Damon can get: Each die has 6 sides, so the total number of possible outcomes is $6 \times 6 \times 6 = 216$. Now count out how many of those outcomes total more than 16. There are 3 ways to roll a 17—5, 6, and 6, 6, 5, and 6, and 6, 6, and 5—and 1 way to roll an 18—three 6's. The probability is thus $\frac{4}{216}$, which reduces to $\frac{1}{54}$.

5. B and D

If you pare down the problem, then it is much simpler than it first appears. There will be 1 house on Surf Street at which a turtle will lay its eggs; this is "the number of outcomes you want." There are a total of 5 houses, which is the "total number of possible outcomes." Therefore, if John spends the summer on Surf Street, the probability of John staying in the house where the sea turtle will lay its eggs is choice (B), $\frac{1}{5}$, and the information about the landside houses versus seaside houses actually turns out to be unnecessary. Similarly, if John stays on Breaker Way, there will be 1 house that a turtle will lay its eggs at out of a total of 3 possible houses that John could live in. Therefore, if he lives on Breaker Way, there is a $\frac{1}{3}$ chance that the turtle lays its eggs outside John's house, and this makes choice (D) correct.

6. $\frac{10}{3}$ The most efficient way to approach this tough problem is to plug in prime numbers to determine the set of values that satisfies the inequality. Plugging 2 in for x yields $\frac{1}{8} \leq \frac{5}{4}$ which is true. Plugging in 3 yields $\frac{1}{7} \leq \frac{5}{9}$ which is also true. Plugging in 5 yields $\frac{1}{5} \leq \frac{5}{25}$ so the two sides are equal, so that's probably the maximum value of x. To be sure, check the next prime number, 7: $\frac{1}{3} \leq \frac{5}{49}$ which is false. You should also check a large prime number to confirm {2, 3, 5} is the solution set. If you do, you'll find the inequality is false and {2, 3, 5} is the full set of values. To find the average of the numbers, use the Average Pie: $\frac{2+3+5}{3} = \frac{10}{3}$

7. C There are variables in the answer choices, so Plug In. Try x = 3. Now write out your new set of numbers. Since you are subtracting 3 and adding 3 the same number of times, the sum and average stay the same, so eliminate choices (A) and (B). The median decreases by 0.5, so eliminate choices (F) and (G). There are now two modes in the set, so eliminate choice (D). The distance of the numbers from the mean changes in the new set, so the standard deviation is not the same. Eliminate choice (E). The correct answer is choice

8. 7.6 Alejandra's average equals $227 \div 5 = 45.4$. Nigel's average equals $189 \div 5 = 37.8$. The difference is 7.6.
9. B First place the known values from the question in order: 56, 86, 97, 98. From the restriction, you know that x can only be placed in two slots: first (before 56) and second (between 56 and 86). In both cases, the middle number of the full set is 86, making choice (B) the only correct choice.
10. $\frac{14}{40}$ First figure out how many marbles of each color are in the jar. For blue: $\frac{1}{5}$ of 40 is 8, so there are 8 blue marbles and 32 other marbles. For red: $\frac{1}{4}$ of 32 is 8, so there are 8 red marbles and 24 marbles that are neither red nor blue. As there are 10 green marbles, there are 14 marbles left that are not green, red, or blue. Thus, the probability of selecting one of those marbles is $\frac{14}{40}$. If you answered $\frac{26}{40}$, you found the probability that the selected marble will be blue, red, or green. If you answered $\frac{12}{40}$, for the red marbles you perhaps found $\frac{1}{4}$ of 40 (the total marbles) rather than $\frac{1}{4}$ of 32 (the remaining marbles after blue) in the original calculation.
11. D Set up your standard bell curve with the proper percentage markers of 2%, 16%, 34% on each side of the central average line. Use an average wheel to find the average sales amount in dollars; you should get $91,000 \div 65 = 1400$ as the average. Note that at the 50% mark, and then note the amounts at each deviation above and below the average by adding or subtracting the given standard deviation of \$130. Once you've filled in the curve, look for \$1270 from the question. It is at the 16% mark, indicating that less than 16% of employees sold under \$1270 worth of merchandise. Therefore, the other 84% of employees were able to sell \$1270 or more worth of merchandise, making choice (D) the correct answer.
12. 93 Use the Average Pie. Consider Cliff and Raya's average first: There are 2 of them, and their average is 79, so multiply 2×79 to get their total of 158. Call Cliff's score c , and $c + 73 = 158$, so $c = 85$. Now repeat the process with Jamal and Cliff's average: 2 people with an average of 89, so $2 \times 89 = 178$ total points. Therefore, $x + 85 = 178$, and x is 93.

1. A, C, and D

Draw a bell curve with three standard deviations to the left and the right of mean. Plug in 50 lbs on the leftmost standard deviation as mentioned in the question. Start with choice (A), plug in 80 lbs for the mean, and solve for the standard deviation. In this case it would be 10, and it's possible to see that 110 would be the third standard deviation to the right of the mean. Therefore, choice (A) satisfies the question. If you repeat this with choice (B), you'll find that the standard deviation would have to be 11.67. Thus, the value two standard deviations to the right of the mean is 108, and is just shy of what you want. In choice (C), the mean is 86, the standard deviation is 12, and 110 will be the second deviation to the right of the mean. Choice (D) works; the mean is 95, standard deviation is 15, and 120 is the first value to the right of the mean. You can ballpark to eliminate choice (E). Its standard deviation is about 16, and the first standard deviation to the right would be about 116, which means 110 cannot fall on a standard deviation.

2. B Use the Rate Pie. Ali is traveling 50 feet per second faster than Jeff is traveling. Therefore, that is the rate at which she is effectively gaining ground on him. Put that in the lower-right segment of the Rate Pie. We want to know how long it will take her to gain 3,000 feet on him. Put 3,000 in the top section of the Rate Pie. Now you can see that dividing $\frac{3000}{50}$ will fill in the last segment of the Rate Pie, telling you how long it takes Ali to do so is 60 seconds. Be aware that choice (E) is an incorrect partial answer. Now you need to find out how many feet Ali will travel in 60 seconds, by multiplying 60 second \times 300 feet per second, which equals 18,000 feet. Divide 18,000 feet by the length of one lap, or 3,000 feet, and you'll find that it will take Ali 6 laps to overtake Jeff.

3. $\frac{3}{10}$ or 0.3

You don't know how many trees there are, so define the job by plugging in an easy number, such as 21 trees. Use rate pies to figure out that Helen's rate is 7 trees/hr and Sergey's rate is 3 trees/hr. That means their combined rate is 10 trees/hr. Put their combined rate into another rate pie with the total trees to find it takes them $\frac{21}{10}$ or 2.1 hours to meet. To find out how many trees Sergey has cut down at this point, put his individual rate into another rate pie with 2.1 hours. 3 trees/hr \times 2.1 hours = 6.3 trees at the point they meet. Put the number of trees Sergey has cut when they meet over the total trees: $\frac{6.3}{21} = \frac{3}{10}$, so the correct answer is $\frac{3}{10}$ or 0.3.

4. E Start by plugging in a set of consecutive integers that encompasses the full spectrum of integers, such as $-2, -1, 0, 1, 2$. The average and median of the set are both 0. In any set of consecutive integers, the average will always equal the median. Performing the operations in choices (A), (B), (C), and (F) results in sets of numbers that are still consecutive. Thus, while in choices (B), (C), and (F) the averages change, the medians also change to those same values. Eliminate choices (B), (C), and (F). In choice (A), neither the average nor the median changes, so you can eliminate it as well. For choice (D), the new average is -1.64 and the new median is -8.2 . Again, both values change, so you can eliminate choice (D). In choice (E), the new average is $.4$, but the median hasn't changed; choice (E) works. You can eliminate choice (G) based on the other calculations, and the only correct answer is choice (E).

5. E and G

Plug in numbers for p, s, and h, such as 2, 3, and 4, respectively. If Paul can grade 2 essays every half hour, then in 4 hours, he will grade 16 essays. If Sarah can grade 3 essays every hour, then in 4 hours, she will grade 12 essays. Thus, Paul and Sarah will grade a total of 28 essays. Now, plug your numbers into each answer choice. Choices (E) and (G) result in 28. If you Plugged In and choice (F) also worked, you picked the same number for Paul and Sarah. If you picked choice (C), you didn't notice that Paul grades p essays every half hour, not every hour.

6. E Use the Average Pie to solve each part of the problem. If the average of 5 numbers is 36, then the sum of those numbers is 180. If the average of four of the numbers is 34, then the sum of those numbers is 136.

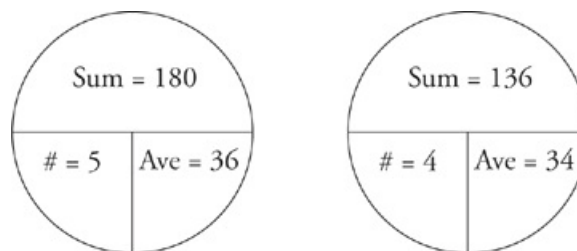

If five numbers add up to 180 and four of those five numbers add up to 136, then the fifth number is the difference between those two sums: $180 - 136 = 44$. If you picked choice (A), you found the difference between the two averages, not the fifth number. If you picked choice (C), you found the average of the averages. If you picked either choice (B) or choice (D), you re-solved for the average

7. 17 Use the Rate Pie to organize your work. For the first 5 weeks, Noah's company builds 1 mile per week. Therefore, they build 5 miles of road before the start of the rainy season. Once rainy season begins, they have 6 miles of road left to build. This number is the "work," and goes in the top of the rate pie. The rate, $\frac{1}{2}$ miles per week, goes in the lower left segment of the rate pie. Divide 6 by $\frac{1}{2}$ and you'll get the total amount of time, or 12 weeks, at that rate. Therefore, it will take a total of 17 weeks for Noah's company to build the road.

8. A, D, and F

Plug in for y. If $y = 30$, then Employee A produces 30 DVDs in $\frac{2}{5}$ of an hour, so using a Rate Pie you can figure out that his rate is 75 DVDs per hour. Employee B produces 30 DVDs in $\frac{3}{5}$ of an hour, so his rate is 50 DVDs per hour. Employee C produces 30 DVDs in $\frac{5}{4}$ of an hour, so his rate is 24 DVDs per hour. $5y = 150$, so you need to find the combination of employees that can produce 150 DVDs in 2 hours. Employee A will produce exactly 150 DVDs in 2 hours, so choice (A) is a credited answer. If you know that Employee A alone can produce 5y DVDs in 2 hours, then choices (D) and (F) must also be correct answers, and choice (G) must be incorrect. Employee B will only produce 100 DVDs in 2 hours, so you can eliminate choice (B). Employee C will only produce 48 DVDs in 2 hours, so you can also eliminate choice (C). If Employees B and C work together for 2 hours, they will produce 148 DVDs, so choice (E) is incorrect.

9. 25 Cyclist A rode for 3.5 hours at 20 miles per hour, so she traveled $20 \times 3.5 = 70$ miles. Cyclist B then, must have traveled $145 - 70 = 75$ miles. Since Cyclist B left at 2:00, she rode for 3 hours, giving her a speed of $75 \div 3 = 25$ miles per hour.

10. D The question is asking for a specific amount and there are no variables in the answers, so PITA. Starting with choice (C), if the probability of her getting a dude is $\frac{2}{5}$, then the probability of her getting a dud is $\frac{5}{5} - \frac{2}{5} = \frac{3}{5}$. Thus, the probability of her getting two consecutive duds is $\frac{3}{5} \times \frac{3}{5} = \frac{9}{25}$, which is too big. Eliminate choice (C). To get a smaller chance of getting two duds, you need a larger chance of getting a dude; eliminate choices (A) and (B). In choice (D), the probability of her getting a dude is $\frac{3}{5}$, which means the probability of her getting a dud is $\frac{5}{5} - \frac{3}{5} = \frac{2}{5}$. Thus, the probability of her getting two consecutive duds is $\frac{2}{5} \times \frac{2}{5} = \frac{4}{25}$, which matches the probability mentioned in the question. The correct answer is choice (D).

11. 1.28 First, find the two people's rates in terms of miles per hour (mph). Victor's rate equals distance over time, or 1 mile over $\frac{17}{60}$ hours, which equals approximately 3.529 mph. Calculating Sarah's speed using the same steps gives you her rate, 4.286 mph. When added, the two rates become their combined rate of 7.815 mph. When you divide 10 miles by 7.815, the answer is approximately 1.28 hours until they meet.



Groups, Sequences, and Functions

GROUPS, SEQUENCES, AND FUNCTIONS

None of these concepts show up very frequently on the test. Therefore, if you have only a limited amount of time to prepare, spend it on Plugging In, geometry, exponents and square roots, and other concepts that you are guaranteed to see. As a general rule, the more questions on a particular subject that are in this book, the more likely those questions are to show up on your test.

GROUPS

There are two kinds of group problems on the GRE. Both include overlapping groups. Because of this, you have to be careful so that you don't confuse one for the other. As usual, once you recognize the type, use the appropriate set-up on your scratch paper, and organize your information, the solutions end up being a matter of simple arithmetic.

The first type of group problem you will recognize because it will include the words NEITHER and BOTH.

Example:

Of the 60 employees of company X, 22 have laptops, and 52 have desktop computers. If 12 of the employees have neither laptops nor desk tops, how many employees have both?

Once you recognize the type of problem, use the formula

$$\text{Total} = \text{Group 1} + \text{Group 2} + \text{Neither} - \text{Both}$$

So, $60 = 22 + 52 + 12 - x$. $x = 26$.

The first type includes two overlapping groups and a population that might belong to one, the other, neither, or both. The second type actually involves four overlapping groups and a population that can belong to any two of the groups at one time. There is no option for NEITHER in this type of group problem.

Example:

Of the 60 employees at company X 25 use Macs and 35 use PCs. Four-fifths of the Mac users are in the graphics department and there are 40 people in the graphics department total, how many of the non-graphics employees use a PC?

To solve these problems, just get your pencil on your scratch paper and organize your information in a grid.

	Mac	PC	Total
Graphics	20	20	40
Non-Graphics	5	15	20
Total	25	35	60

SEQUENCES

Sequence questions are really all about pattern recognition. You will recognize them because they will ask you specifically about a sequence of numbers, as in, "Each term in the sequence above is twice the previous term minus one. What is the value of the sixth term in the sequence?" or because they will involve a number that is too big to calculate, as in, "What is the value of the tens digit of $5^{26} - 6$?"

In both cases you will find the phrase, "What is the value of?" This is a sure tip-off that you can plug in the answer choices. As always, when you see this phrase, label your first column, assume choice (C) to be the correct answer, and work through the problem in bite-sized pieces making a new answer choice for every step.

It may be the case that this problem is really a simple matter of following directions. If that is the case, you will have to go through multiple steps to get to the correct answer. Make sure you work slowly, carefully, methodically, and, above all, do your work on your scratch paper.

In the second case, you will never be asked to calculate 5^{26} . The question contains the phrase, "What is the value of..." but there is still no way to calculate a number of that size, even with the answer choices. Therefore, there must be a pattern. Begin to calculate the sequence, starting from the lowest term and working up. When the pattern emerges, figure out how often it repeats itself (Every third term? Every fourth term? Every fifth?). If the pattern repeats itself every fourth term, then the value of the ones digit on the eighth term will be the same as the one on the fourth term. It will be the same, as well, on the twelfth, the sixteenth, the twentieth, the fortieth, and the forty-fourth. To find the value on the twenty-sixth term, just find the value on the twenty-fourth term and count up two.

FUNCTIONS

If you see a strange symbol on the GRE, (it could be a star, a clover, a letter of the Greek alphabet) it doesn't mean that math has changed since you left high school and they've rewritten all of the text books. It just means that you are seeing a rare functions question. The symbol will be attached to a variable and an equal sign. It acts like a series of instructions and tells you what to do in generic terms.

Example:

If $x \heartsuit y = \left(\frac{x+y}{4}\right)^2$ for all integers x and y , then $10 \heartsuit 6 =$

As crazy as it looks, all this problem is telling you to do is plug in a 10 every time you see an x and a 6 every time you see a y in the equation, $\left(\frac{x+y}{4}\right)^2$. Use your scratch paper, be meticulous, and follow directions. It's not upper-level math, just basic arithmetic with weird looking symbols.

For more practice and a more in-depth look at The Princeton Review math techniques, check out our student-friendly guidebook, *Cracking the New GRE*.

DRILL 1

Question 1

If the function f is defined by $f(x) = 2x + 5$, what is the value of $f(4)$?

- 17
- 15
- 13
- 11
- 9

Question 2

Let the “par” of a rectangle be defined as one half the area of that rectangle.

Quantity A

Quantity B

The par of a rectangle with a perimeter of 24 and a width of 2

11

- Quantity A is greater.
- Quantity B is greater.
- The two quantities are equal.
- The relationship cannot be determined from the information given.

Question 3

3, 4.5, 6, 7.5,...

Each term in the sequence above is formed by adding the positive number k to the preceding term.

Quantity A

Quantity B

The eighth term in the sequence above

14

- Quantity A is greater.
- Quantity B is greater.
- The two quantities are equal.
- The relationship cannot be determined from the information given.

Question 4

The operation denoted by the symbol \rightarrow is defined for all real numbers a and b as $a \rightarrow b = a\sqrt{b}$. What is the value of $3 \rightarrow (2 \rightarrow 4)$?

- $\frac{1}{4}$
- 4
- 6
- $6\sqrt{2}$

Question 5

Each of the even-numbered terms in a certain sequence is formed by multiplying the preceding term by -1 . Each of the odd-numbered terms in the sequence is formed by adding 3 to the preceding term. If the first term in the sequence is 3, then what is the 168th term?

- 3
 -1
 0
 1
 3

Question 6

Quantity AQuantity B

The sum of all the even integers from 18 to 36 inclusive

The sum of all the even integers from 22 to 38 inclusive

- Quantity A is greater.
 Quantity B is greater.
 The two quantities are equal.
 The relationship cannot be determined from the information given.

Question 7

A club of 65 people includes only standard members and gold members. Of the club's 30 gold members, 18 are men. Exactly 20 women are standard members.

Quantity AQuantity B

The number of standard members who are men

13

- Quantity A is greater.
 Quantity B is greater.
 The two quantities are equal.
 The relationship cannot be determined from the information given.

Question 8

$$x\# = x^2 + 3x$$

$$x\§ = x^2 + 2x$$

Quantity AQuantity B $(x\§)\#$ $(x\#)\§$

- Quantity A is greater.
 Quantity B is greater.
 The two quantities are equal.
 The relationship cannot be determined from the information given.

Question 9

Mary is building a pyramid out of stacked rows of soup cans. When completed, the top row of the pyramid contains a single soup can, and each row below the top row contains 6 more cans than the one above it. If the completed pyramid contains 16 rows, then how many soup cans did Mary use to build it?

- 91
 96
 728
 732
 736

Question 10

The sequence of numbers $S = \{s_1, s_2, s_3, \dots\}$ is defined by $s_1 = 2$, $s_2 = 10$, and $s_n = s_{n-1}^{s_{n-2}}$ for each positive integer n greater than or equal to 3. For example, $s_3 = 10^2$. What is the greatest value of n for which s_n has 2,000 or fewer digits?

- 100
 20
 5
 4
 3

Question 11

$$f(x) = x^2 + 1$$

$$g(x) = x - 2$$

Quantity A

$$f(g(-1))$$

Quantity B

$$g(f(-1))$$

- Quantity A is greater.
 Quantity B is greater.
 The two quantities are equal.
 The relationship cannot be determined from the information given.

Question 12

The “pluck” of a circle is defined as the area of the circle divided by π . What is the pluck of a circle with radius 5 ?

Question 1

a is the sum of the second and third positive integer multiples of a .

Quantity A

5

Quantity B

15

- Quantity A is greater.
- Quantity B is greater.
- The two quantities are equal.
- The relationship cannot be determined from the information given.

Question 2

A certain vent releases steam every 20 minutes. If the vent releases steam at 6:25 p.m., which of the following could be a time at which the vent releases steam?

- 9:15 p.m.
- 10:40 p.m.
- 11:00 p.m.
- 12:20 p.m.
- 1:05 a.m.

Question 3

For all nonzero integers l and m , let the operation $\$$ be defined by $l \$ m = -\frac{l+m}{lm}$.

Quantity A

 $3 \$ \frac{3}{2}$

Quantity B

-1

- Quantity A is greater.
- Quantity B is greater.
- The two quantities are equal.
- The relationship cannot be determined from the information given.

Question 4

There are 30 students in Mr. Peterson's gym class. 14 of them play basketball, 13 play baseball, and 9 play neither basketball nor baseball.

Quantity A

The number of students who play both basketball and -
baseball

Quantity B

6

- Quantity A is greater.
- Quantity B is greater.

- The two quantities are equal.
- The relationship cannot be determined from the information given.

Question 5

In a regular n -sided polygon, the measure of a single angle is $\frac{(n-2)180^\circ}{n}$. The degree measure of an angle in a regular 10-sided polygon is how much greater than the degree measure of an angle in a regular 6-sided polygon?

Question 6

For all real numbers a and b , the operation \oplus is defined by $a \oplus b = 2a - b$. What is the absolute value of the difference between $(3 \oplus 1) \oplus 2$ and $6 \oplus 3$?

Question 7

Starting with the third term, each term in Sequence S is one-half the sum of the previous 2 terms. If the first 2 terms of Sequence S are 64 and 32, respectively, and the n^{th} term is the first non-integer term of Sequence S, then $n =$

Question 8

Quantity A

The units digit of 7^{29}

Quantity B

The units digit of 3^{27}

- Quantity A is greater.
- Quantity B is greater.
- The two quantities are equal.
- The relationship cannot be determined from the information given.

Question 9

Of the employees at a company, 60 percent were men and, of these, $\frac{1}{10}$ were still employed after a recent corporate restructuring. If the number of women who were still employed after the restructuring was five times the number of men who were employed after it, what percent of the women were still employed after the restructuring?

- 6%
- 20%
- 30%
- 50%
- 75%

Question 10

If q is even, then $\#q = -2$;

If q is odd, then $\#q = -4$.

a and b are integers such that $b - 3$ is odd.

- Quantity A is greater.
- Quantity B is greater.
- The two quantities are equal.
- The relationship cannot be determined from the information given.

Question 11

$$f(x) = 3x^2$$

$$g(x) = x + 1$$

x is an integer such that $-10 \leq x \leq -1$.

Quantity A

 $f(g(x))$

Quantity B

 $g(f(x))$

- Quantity A is greater.
- Quantity B is greater.
- The two quantities are equal.
- The relationship cannot be determined from the information given.

Question 12

Three digits have been removed from each of the following numbers. If $n = 25$, which of the numbers is equal to $3 \times 2^{n-1}$?

- 47, _ _6, _23
- 47, _ _6, _32
- 49, _ _2, _64
- 49, _ _2, _36
- 50, _ _1, _48

ANSWERS

Drill 1

1. C
2. B
3. B
4. C
5. C
6. C
7. A
8. D
9. E
10. D
11. A
12. 25

Drill 2

1. A
2. E
3. C
4. C
5. 24
6. 1
7. 8
8. C
9. E
10. C
11. B
12. E

Drill 1

- C If $f(x) = 2x + 5$, then $f(4) = 2(4) + 5 = 13$.
- B Draw it. The rectangle in Quantity A has two sides of 2, for a total of 4. The remaining 20 units in the perimeter are divided evenly into two sides of length 10; the area of this rectangle is $lw = (2)(10) = 20$, and the “par” is one half that, or 10. Quantity B is greater.
- B Notice that each term in the sequence is 1.5 greater than the last (i.e., $k = 1.5$). So the second term is $3 + 1.5 = 4.5$, the third term is $4.5 + 1.5 = 6$, and so forth. So the fifth term is $7.5 + 1.5 = 9$, the sixth term is $9 + 1.5 = 10.5$, the seventh term is $10.5 + 1.5 = 12$, and finally, the eighth term is $12 + 1.5 = 13.5$. So, Quantity A is 13.5, and the answer is choice (B). Another way to attack this problem is to use the sequence formula of $3 + 1.5(n - 1)$, where the 3 is the first term, the 1.5 is the increase, and you are looking for the n th term. So, the 8th term is $3 + 1.5(8 - 1) = 13.5$.
- C To follow the order of operations, first evaluate the expression in parentheses. $3 \rightarrow (2 \rightarrow 4) = 3 \rightarrow 2\sqrt{4} = 3 \rightarrow 4 = 3\sqrt{4} = 6$. The answer is choice (C).
- C Write out sequences until you see the pattern. The second term in the sequence is $3(-1) = -3$. Adding 3 gives you the third term, 0. Multiplying by -1 gives you the fourth term, also 0. Adding 3 gives you 3, the fifth term. So the sequence repeats every four terms: 3, -3 , 0, 0, 3, -3 , 0, 0, and so forth. Dividing 168 by 4 gives you a remainder of zero, and the fourth, eighth, twelfth, and every other n th term where n is a multiple of 4 (including the 168th term) will all be the same value, 0. The answer is choice (C).
- C Even if you know the summation formula, you can avoid a lot of time-consuming calculation by disregarding the numbers that are common to both sums—the even integers from 22 to 36, inclusive. That leaves $18 + 20 = 38$ as the sum of the unique terms in Quantity A, and 38 as the only unique term in Quantity B. The quantities are equal.
- A Set up a group grid and fill in what you have:

	Men	Women	Total
Standard		20	
Gold	18		30
Total			65

Use this to find that there are $65 - 30 = 35$ total standard members. So there are $35 - 20 = 15$ standard male members, thus, Quantity A is 15. The answer is choice (A).

- D Whenever you have a function within another function, you have to first calculate the value of the function on the inside, and then plug that value into the function on the outside. Plug in to test the values. If you plug in 2 for x , then, in Quantity A, $2\# = 2^2 + 2(2) = 8$ and $8\# = 8^2 + 3(8) = 88$; in Quantity B, $2\# = 2^2 + 3(2) = 10$ and $10\# = 10^2 + 2(10) = 120$; eliminate choices (A) and (C). However, if you plug in 0 for x , then both quantities are 0; eliminate choice (B), and you’re left with choice (D), the correct answer.
- E The top row contains 1 can, the second row contains $1 + 1(6) = 7$ cans, the third row contains $1 + 2(6) = 13$ cans, and so forth, so that the sixteenth row contains $1 + 15(6) = 91$ cans. But you need to find the total number of cans, which is $1 + 7 + 13 + \dots + 79 + 85 + 91$. Notice that adding the first and last term in the sequence gives you 92. Adding the second and second to last term also gives you 92: As you move to the next term at the beginning of the sequence, you are adding 6, while as you move to the previous term at the end of the sequence, you are subtracting 6, so the sum will remain constant. Thus, for each pair of rows, the sum is 92. Sixteen rows represents eight pairs of rows, so the total number of cans is $(8)(92) = 736$. The answer is choice (E).
- D Decoding the definition of the sequence tells you that, to find the value of each term, you take the previous term, and raise it to the power of the term before it. You know $s_3 = 10^2 = 100$, $s_4 = (10^2)^{10} = 10^{20}$, and $s_5 = (10^{20})^{100} = 10^{2000}$. So s_4 is the digit 1 followed by twenty zeroes, which is a total of 21 digits, and s_5 is the digit 1 followed by 2,000 zeroes, for a total of 2,001 digits. So the fourth term is the one that meets the condition set forth in the question, and the answer is choice (D).
- A For Quantity A, start with the innermost parentheses: $g(-1) = (-1) - 2 = -3$. So $f(-3) = (-3)^2 + 1 = 9 + 1 = 10$. For Quantity B, $f(-1) = (-1)^2 + 1 = 1 + 1 = 2$. So, $g(2) = 2 - 2 = 0$. Thus, Quantity A is greater.
- 25 Ignore the unfamiliar terminology and follow directions. The area of a circle with radius 5 is $\pi r^2 = 5^2\pi = 25\pi$. Dividing the area by π gives you 25.

- A The second positive integer multiple of 5 is 10. The third positive integer multiple of 5 is 15. The sum of 10 and 15 is 25, so Quantity A is larger.
- E Rather than listing out the actual times, figure out the pattern. The vent releases steam at 25, 45, and then 5 minutes after 6 p.m., and repeats this pattern every hour thereafter. Only choice (E) fits the pattern.
- C When a problem gives you a relationship signified by an unfamiliar symbol: Just plug in the given values into the given "function"

and solve. If $l \S m = -\left|\frac{l+m}{lm}\right|$, then $3 \S \frac{3}{2} = -\left|\frac{3+\frac{3}{2}}{3\left(\frac{3}{2}\right)}\right| = -\left|\frac{\frac{9}{2}}{\frac{9}{2}}\right| = -|1| = -1$. The quantities are equal, so select choice (C).

- C Use the group formula and fill in what you know. So Total = Group1 + Group2 - Both + Neither becomes $30 = 14 + 13 - \text{Both} + 9$. So Both = 6, and the answer is choice (C).
- 24 Find the measure of an angle in a regular 10-sided polygon by plugging 10 into the given formula: $\frac{(10-2)180^\circ}{10} = 144^\circ$. Then do the same for a regular 6-sided polygon by plugging 6 into the given formula: $\frac{(6-2)180^\circ}{6} = 120^\circ$. Finally, $144 - 120 = 24$.
- 1 To follow the order of operations, first evaluate the expression in parentheses: $3 \oplus 1 = 2(3) - 1 = 5$, so now the first equation can be written as $5 \oplus 2 = 2(5) - 2 = 8$. Next, rewrite the second equation so that you have $6 \oplus 3 = 2(6) - 3 = 9$. Finally, $|8-9| = |-1| = 1$, so the answer is 1.
- 8 Use brute force to solve this one: Write down the 2 given terms, find half the sum of the previous 2 terms, and repeat the process until you have a non-integer. When you work it out, Sequence S should begin 64, 32, 48, 40, 44, 42, 43, 42.5; the first non-integer term is the 8th term, so $n = 8$.
- C To find the pattern in each sequence, write out the units digit of the first few terms in the sequence. The pattern for the units digit of powers of 7 is: 7, 9, 3, 1. The pattern for the units digit of powers of 3 is: 3, 9, 7, 1. For both numbers, 1 repeats as the units digit every 4 powers, so the 4th power will have a units digit of 1, as will the 8th, the 12th, and so on. Because 28 is a multiple of 4, you know that 7^{28} will have a units digit of 1. So moving forward one in the pattern, 7^{29} will have a units digit of 7. Similarly, 3^{28} will have a units digit of 1, so moving backward one in the pattern, 3^{27} must have a units digit of 7. The quantities are equal, so the answer is choice (C).
- E Set up a group grid and, because you are dealing with percents and fractions, plug in 100 for the total number of employees at the company. There will be 60 men, of whom 6 are still employed after the restructuring. Subtracting 60 from 100 gives you 40, the total number of women. Five times the 6 men who are still employed gives you 30, the number of women still employed. After filling in this information, the group grid looks like the figure below.

	Still employed	No longer employed	Total
Men	6		60
Women	30		40
Total			100

There are 30 women, but the question asks you what percent this represents of the total number of women. 30 out of 40 is 75 percent, so the answer is choice (E).

- C Rather than trying to remember a bunch of rules about even and odd numbers, Plug In for a and b. If a is 2, then 6a is 12, and #12 = -2. Because b - 3 is odd, make b = 6, and #b = -2 as well. The two quantities are equal, so eliminate choices (A) and (B). Any set of values gives the same outcome, so select choice (C).
- B Plugging 10 values into two compound functions is going to involve lots of arithmetic and will take a long time, so it is better to do this one algebraically. Working from the inside out, find Quantity A: $f(g(x)) = f(x+1) = 3(x+1)^2 = 3x^2 + 6x + 3$; remember to FOIL the $(x+1)$ when you square it. Similarly, find Quantity B: $g(f(x)) = g(3x^2) = 3x^2 + 1$. You can add or subtract the same value from both quantities without affecting which is bigger; doing so with $3x^2 + 1$ leaves you with $6x + 2$ in Quantity A and 0 in Quantity B. Because $6x + 2$ is a linear function whose graph is a line with positive slope, you know that the values of the function will increase as the values of x increase. So you only need to plug in the endpoints of the given range of x-values to see what happens to the function: $6(-10) + 2 = -58$ and $6(-1) + 2 = -4$. So all possible values of Quantity A are still less than 0, and the answer is choice (B).

- E The equation $3 \times 2^{n-1}$ follows a pattern. When $n = 1$, the result is 3. When $n = 2$, the result is 6. When $n = 3$, the result is 12.

When $n = 4$, the result is 24. When $n = 5$, the result is 48. When $n = 6$, the result is 96. Beginning with the second term, the final digit in each result follows the pattern: 6, 2, 4, 8, 6, 2, 4, 8, etc. The 25th term will thus end in the same digit as all the other k th terms, where k is one greater than a multiple of 4. Thus, the $(4 + 1)$ th, $(8 + 1)$ th, $(12 + 1)$ th... $(24 + 1)$ th terms all have a final digit of 8, and the only answer in which that is true is choice (E).



Combinations and Permutations

You will recognize these problems because they will ask you about the number of possible combinations, arrangements, groups, or ways to order a number of things or people. You may be asked about toppings on a salad, members in a group or on a committee, children in a line, or runners in a race.

When doing these problems there are only two possible numbers you can generate, a big one and a small one. The big one happens when order matters, the small one happens when order does not matter.

EXAMPLE 1

Supposed you are asked for the number of different ways eight runners come in first, second, or third in a race. The first step is to make slots on your scratch paper. You are looking at the runners in first, second, or third place; therefore you need three slots.

Before the race starts, everyone is a winner, or at least a potential winner, so there are eight possible runners who could come in first place. Once one runner comes in first, there are seven potential runners left who could come in second place, and six left for third place.

$$\underline{8} \underline{7} \underline{6}$$

To figure out the number of ways eight runners could finish first, second, and third in a race, simply multiply all three numbers. Order, in the case of runners in a race, is highly significant. If Tom comes in first place, Jenny in second, and Alicia in third, that is one arrangement, but if Alicia comes in first, Tom in second, and Jenny in third, it counts as a new arrangement. There are 336 possible arrangements.

EXAMPLE 2

Now imagine that you are asked to find the number of different ways eight senators can be arranged on a three-person committee. There are three seats on the committee so you need three slots. The problem begins the same way. There are eight potential senators for the first slot, seven for the second, and six left for the third.

$$\underline{8} \underline{7} \underline{6}$$

As opposed to the situation of the runners in a race, however, order, in this case, does not matter. A committee made up of Ross, LB, and Shirley or a committee made up of LB, Shirley, and Ross is the same committee. The larger number counts each of these committees separately. You need a way to get rid of all of these committees of the same three people that you've counted just because they are in a different order. The way to do this is to divide by the factorial of the number of slots. It sounds complicated, but in reality, all you have to do is count down the number of slots in the divisor.

$$\frac{\underline{876}}{321}$$

Before you multiply, reduce your fractions. You will always be able to reduce all of the numbers in the denominator. The three and the two each go evenly into the six once, so you are simply left with 56 (8×7). There are 56 different committees that can be made from a group of eight senators.

SUMMARY

That's it. It doesn't have to be anymore complicated than that. There are two numbers you can produce, a bigger one and a smaller one. The bigger number happens when order matters. In this case, just figure out the number of slots, fill in the numbers, and multiply across the top. The smaller number happens when order doesn't matter. In this case, figure out the number of slots, fill in the numbers on the top and count down the number of slots on the bottom, then reduce and multiply whatever remains.

Occasionally, if you are doing really well, they will give you some rules for your slots. For example, you might have three boys and four girls lining up for gym class. The question may ask you how many different ways they can be arranged in a line, but might stipulate that there must be a girl in first and last place. In this case, the approach is the same, just start with the slots that have the rules—we call these the restricted slots.

There are seven slots total because there will be seven children in the line. The first slot must be a girl, so there are four potential girls for that slot. The last slot must be a girl too, so there are three girls left who can stand last in line. The second slot is wide open. There are six children—four boys and two remaining girls—who are available for the second slot, five for the third, four for the forth, and so on.

Your scratch paper will look like this.

$$\underline{4} \underline{6} \underline{5} \underline{4} \underline{3} \underline{2} \underline{3}$$

Because order matters and every different arrangement of students must be counted separately, you want the bigger number. Simply multiply across the top, and you are done. There are 1,080 different ways three boys and four girls can be arranged in a line with a girl at the head of the line and the back.

For more practice and a more in-depth look at The Princeton Review math techniques, check out our student-friendly guidebook, *Cracking the New GRE*.

DRILL 1

Question 1

A club consists of 8 women and 8 men.
The club has a president and a vice president.
No club member can hold more than one position.

Quantity A

The number of possible assignments such that a woman is president and a man is vice president

Quantity B

The number of possible assignments such that both the president and vice president positions are filled by women

- Quantity A is greater.
- Quantity B is greater.
- The two quantities are equal.
- The relationship cannot be determined from the information given.

Question 2

Given an alphabet of 26 letters, with 21 consonants, and 5 vowels, approximately how many three-letter words can be formed with a vowel as the middle letter and a consonant as the last letter?

- 1000
- 1500
- 2500
- 3500
- 4000

Question 3

Of the 100 eighth-graders at Easton Junior High, 60 students take gym, 40 take a foreign language, and 30 take both gym and a foreign language.

Quantity A

30

Quantity B

The number of students taking neither gym nor a foreign language

- Quantity A is greater.
- Quantity B is greater.
- The two quantities are equal.
- The relationship cannot be determined from the information given.

Question 4

Graham's Catering Service currently employs three chefs and offers three different meals. For an upcoming event, the catering service must provide three meals, with each chef cooking one of the meals.

Quantity A

The number of assignments of chefs to meals if each chef must cook a different meal

Quantity B

The number of assignments of chefs to meals if each chef may cook any of the three meals

- Quantity B is greater.
- The two quantities are equal.
- The relationship cannot be determined from the information given.

Question 5

A certain password must contain 3 distinct digits followed by 2 distinct capital letters. Given ten digits and 26 capital letters, how many different passwords are possible?

Question 6

190 students go to a school bake sale. 95 buy a chocolate chip cookie, 75 buy a peanut butter cookie, and at least 12 buy both. What is the least number of students who could have bought neither type of cookie?

- 10
- 24
- 30
- 32
- 45

Question 7

Geoff is setting up an aquarium and must choose 4 of 6 different fish and 2 of 3 different plants. How many different combinations of fish and plants can Geoff choose?

- 8
- 12
- 18
- 45
- 90

Question 8

If the current day and time is 9:30 p.m. on Tuesday, what time will it be (to the nearest minute) 100,000 seconds from now?

- 1:17 a.m., Wednesday
- 3:47 p.m., Wednesday
- 1:10 a.m., Thursday
- 1:17 a.m., Thursday
- 2:17 a.m., Thursday

Question 9

What is the difference between the number of three-member committees that can be formed from a group of nine members and the total number of ways there are to arrange the members of such a committee?

- 0
- 84

- 252
- 420
- 504

Question 10

Six students compete in a table tennis tournament. Each student plays each of the other students four times. What is the total number of games played in the tournament?

Question 11

A four-person leadership committee is to be chosen from a student council that consists of seven juniors and five seniors. Q is the total number of different leadership committees that include three seniors and one junior.

Quantity A

Q

Quantity B

75

- Quantity A is greater.
- Quantity B is greater.
- The two quantities are equal.
- The relationship cannot be determined from the information given.

Question 12

Contestants at a baking contest must use between 5 and 8 of 10 possible ingredients.

Quantity A

Quantity B

The number of ingredients that must be used to get the smallest possible number of different combinations

The number of ingredients that must be used to get the largest possible number of different combinations

- Quantity A is greater.
- Quantity B is greater.
- The two quantities are equal.
- The relationship cannot be determined from the information given.

Question 13

Depending on the night, a pizza restaurant offers anywhere from seven to nine different choices of toppings. Sam wants a pizza with three toppings. Which of the following could be the number of different ways that Sam can order his pizza with three different toppings?

Indicate all possible values.

- 35
- 42
- 56
- 84
- 210

Question 14

Depending on the day, an ice cream shop offers seven to nine possible ice cream flavors and three to four possible sauces. A Deluxe Sundae consists of two different types of ice cream and two different sauces. Which of the following could be the number of different Deluxe Sundaes that Eva can order?

Indicate all possible values.

36

54

84

216

432

864

DRILL 2

Question 1

Six state governors meet at an annual convention. They line up in random order to pose for a photograph. If the governors of Alaska and Hawaii are among the six governors, how many different ways can the governors line up for the picture so that these two governors are adjacent?

- 5
- 10
- 120
- 240
- 720

Question 2

If Jeff has four movies, and must choose to watch either 1, 2, or 3 different movies, which of the following represents a possible number of different arrangements of movies that Jeff could watch?

Indicate all possible values.

- 4
- 6
- 7
- 9
- 12
- 24

Question 3

Jess has nine different statues and chooses three to arrange in a display. How many arrangements can she make?

Question 4

Of a group of 10 PTA members, a committee will be selected that has 1 president and 3 other members. How many different committees could be selected?

Question 5

Esteban's restaurant offers a lunch special. A customer can order a platter consisting of four different small dishes from a selection of twelve choices. How many different platters can a customer create?

- 24
- 144
- 495
- 11,880
- 20,736

Question 7

For her Halloween display, Margaret plans to arrange a row of alternating witch and ghost figurines. The row must begin with a witch figurine and end with a ghost figurine. Margaret plans to purchase either three of each type of figurine or four of each type of figurine, and each figurine will look unique. Depending on how many figurines she purchases, which of the following could be the number of ways that she could arrange her display?

Indicate all possible values.

- 6
- 24
- 36
- 72
- 576
- 720
- 40,320

Question 8

There are six cars in a motorcade. How many different arrangements of cars in the motorcade are possible?

- 6
- 21
- 72
- 120
- 720

Question 9

Mark can take three friends with him on a vacation and is listing the possible combinations of friends. If he has five friends to choose from and is numbering each possible combination sequentially beginning with 1, which of the following numbers will appear on his list of combinations?

Indicate all possible values.

- 2
- 10
- 15
- 24
- 60
- 120

Question 10

Twelve runners enter a race to compete for first, second, and third place. How many different combinations of winners are possible?

Question 11

Sherry supervises a crew of maintenance engineers for an office building. If there are 5 experienced maintenance engineers and 3 apprentice engineers and the engineers are sent out on jobs in teams, which of the following must be true?

Indicate all possible values.

- There are 10 different 3-person teams of experienced engineers she could send.
- There are 3 different 2-person teams of apprentice engineers she could send.
- There are 2 different 2-person teams of apprentice engineers she could send.
- There are 10 different 2-person teams of experienced engineers she could send.
- There are 10 different 4-person teams of experienced engineers she could send.

Question 12

All employees at Company W are assigned unique employee ID codes that consist of numbers and letters from the alphabet. If letters can be repeated within the same code but numbers cannot, which of the following must be true?

- There are 2,600 possible different 3 digit codes consisting of 1 letter and 2 digits.
- There are 60,840 possible different 4 digit codes consisting of 2 letters and 2 numbers.
- There are 650 possible 2 digit codes consisting of 1 letter and 1 digit.

Question 13

For his birthday, Brian will receive either three or four differently colored ties, either two or three differently colored shirts, and either one or two differently colored jackets. Depending on how many ties, shirts, and jackets he receives, which of the following values could be the number of ways he could make an outfit with one tie, one shirt, and one jacket?

Indicate all possible values.

- 6
- 8
- 9
- 10
- 12
- 16
- 18

Question 14

Paul and Allen are choosing ties out of a selection of three distinct red ties, five distinct green ties, and six distinct blue ties. If Paul and Allen each wear one tie, how many different ways could they wear ties of the same color?

ANSWERS

Drill 1

1. A
2. C
3. C
4. B
5. 468,000
6. D
7. D
8. D
9. D
11. 60
11. B
12. A
13. A, B, D
14. C, D

Drill 2

1. D
2. A, E, F
3. 504
4. 840
5. C
6. 660
7. C, E
8. E
9. A, B
10. 1320
11. A, B, D
12. B
13. A, B, C, E, F, G
14. 56

Drill 1

- A For Quantity A, there are 8 options for president and 8 options for vice president, giving you $8 \times 8 = 64$ total assignments. For Quantity B, once you pick a woman to be president, there are only 7 women left to be vice president, giving you $8 \times 7 = 56$ assignments. The answer is choice (A).
- C When you see the word approximately, you are being told to ballpark. In this case, you have 26 possible letters for that slot, 5 for the second slot, and 21 for the third slot. Estimate and call this $25 \times 20 \times 5$. The total is 2,500, so select choice (C).
- C Substitute the given values into the groups equation: Total = Group 1 + Group 2 - Both + Neither. $100 = 60 + 40 - 30 + N$, giving you $N = 30$, choice (C).
- B Quantity A places a restriction on which meals a chef can cook because each chef must cook a distinct meal. In this case, there would be $3 \times 2 \times 1 = 6$ different assignments. Quantity B does not place a restriction on which meals a chef can cook. In this case, there would be $3 \times 3 \times 3 = 27$ different assignments, choice (B).
- 468,000
List the number of possible options for each character in the password. There are 10 possibilities for the first digit, 9 left for the second, and 8 left for the third. There are 26 possibilities for the first letter and 25 for the second. There are $10 \times 9 \times 8 \times 26 \times 25 = 468,000$ possible passwords.
- D Substitute the given values into the groups equation: Total = Group 1 + Group 2 - Both + Neither. So $190 = 95 + 75 - 12 + N$. $N = 32$. If you pick a number larger than 12 to represent the number of students who buy both cookies, the number that buy neither cookie also increases. The question asks for the least number that bought neither cookie, so the answer is choice (D).
- D First find the number of groups of fish he can select. This is your number of slots: . There are six fish he can choose for the first slot, 5 for the second and so on: 6 5 4 3. Since order doesn't matter, you need to divide by the factorial of the number of slots: $\frac{6213}{4321}$.
Reduce your number to get $3 \times 5 = 15$. For plants you have two slots so $\frac{3}{2} \times \frac{2}{1} = 3$. $3 \times 15 = 45$. The answer is choice (D).
- D Dividing 100,000 seconds by 3,600 seconds per hour, you get 27 hours plus $\frac{7}{9}$ hr. Multiplying $\frac{7}{9}$ hr by 60 minutes per hour, you get $46\frac{2}{3}$ minutes. Therefore, to the nearest minute, 100,000 seconds is equal to 27 hours, 47 minutes. After 24 hours, the time will be 9:30 p.m. Wednesday; 3 hours, 47 minutes after that, it will be 1:17 a.m., Thursday, choice (D).
- D To find the number of different committees. Make your slots and divide by the factorial $\frac{987}{321} = 84$; eliminate choice (B). To find the number of ways to arrange the committee members, just multiply $9 \times 8 \times 7 = 504$, and eliminate partial choice (E). The difference is $504 - 84 = 420$, choice (D).
- 60 When calculating the number of games, order does not matter. There are two students in each game, so two slots: $\frac{65}{21}$, because order does not matter you will divide by the factorial for 15 combinations. Each student plays 4 games against each of the other students, so $4(15) = 60$ games are played.
- B Start by finding out how many groups of three seniors can be chosen from the five seniors: $\frac{543}{321} = 10$. Next, multiply that total by the number of individual juniors with which those groups can be paired (7) to form the full committee: $10 \times 7 = 70$. Quantity B is greater.
- A You are forming groups where order doesn't matter, so use the combination formula. If you use 5 ingredients, then there are $\frac{109876}{54321} = 252$ different combinations. If you use 6 ingredients there are $\frac{1098765}{654321} = 210$ combinations, if you use 7 there are

$\frac{10}{7} \times \frac{9}{6} \times \frac{8}{5} \times \frac{7}{4} = 120$, and if you use 8 there are $\frac{10}{8} \times \frac{9}{7} \times \frac{8}{6} \times \frac{7}{5} \times \frac{6}{4} \times \frac{3}{2} \times \frac{1}{1} = 45$. Thus, Quantity A is 8, and Quantity B is 5, choice (A).

13. A, B, and D

This problem is about combinations, because order doesn't matter. On a night when the pizza place offers only seven toppings, Sam has $(7 \times 6 \times 5) \div (1 \times 2 \times 3) = 35$ options, choice (A). When the pizza place has eight toppings, Sam has $(8 \times 7 \times 6) \div (1 \times 2 \times 3) = 42$ options, choice (B). And when the pizza place has nine toppings, Sam has $(9 \times 8 \times 7) \div (1 \times 2 \times 3) = 84$ options, choice (D).

14. C and D

Simplify this problem by dealing with the two combinations separately. To select 2 out of 7, 8, or 9 ice creams, calculate

$\frac{7}{2} \times \frac{6}{1}$, $\frac{8}{2} \times \frac{7}{1}$, and $\frac{9}{2} \times \frac{8}{1}$ to yield 21, 28, or 36 possible combinations of ice creams, respectively. Now, do the same thing for sauces:

$\frac{3}{2} \times \frac{2}{1} = 3$, and $\frac{4}{2} \times \frac{3}{1} = 6$, so you have 3 or 6 possible combinations of sauces. The possible numbers of different Deluxe Sundaes,

then, are $21 \times 3 = 63$; $21 \times 6 = 126$; $28 \times 3 = 84$; $28 \times 6 = 168$; $36 \times 3 = 108$; and $36 \times 6 = 216$. Only choices (C) and (D)

work.

1. D This is a permutation because order matters. First, think about the positions for the 2 governors from Alaska and Hawaii. There are 5 pairs of spots they can occupy: first and second, second and third, third and fourth, fourth and fifth, or fifth and sixth. That gives you 5 possibilities; since either governor could come first, you have a total of $5 \times 2 = 10$ possible ways to arrange those 2 governors. Meanwhile, for each of those options, the other governors can assume any of the remaining spots, which equals $4 \times 3 \times 2 \times 1$, or 24 possibilities. The answer is thus $10 \times 24 = 240$, choice (D).
2. A, E, and F
If Jeff watches one movie, he has four different choices for that one movie, so choice (A) is a correct answer. To find the total number of arrangements of two movies, first write out two slots. For the first movie, he has 4 choices and a 4 goes in the first slot. For the second movie, he now has three choices and a 3 goes in the second slot. $4 \times 3 = 12$, so choice (E) is correct. There are 24 arrangements if he watches three movies: $4 \times 3 \times 2 = 24$. Choice (E) is also correct.
3. 504 This problem deals with permutations because the order of the statues matters. Draw three slots for the three positions. You can choose from nine statues for the first spot, eight for the second, and seven for the third. Multiplying these values together gives you 504.
4. 840 There are 10 possible presidents. After the president is selected, there are 9 members left to fill the remaining 3 spots. Order does not matter, so the number of possibilities for the other three spots is $\frac{9 \times 8 \times 7}{3 \times 2 \times 1}$. Simplifying the fraction yields $3 \times 4 \times 7 = 84$. So, there are 10 possible presidents and 84 possible committees for each president. Multiplying them yields the total number of possible committees, 840.
5. C This problem is about combinations, because the order of the dishes does not matter. Since you're choosing 4 dishes, start by drawing 4 blanks. On top, write the number of choices: 12 choices for the first dish, then 11, 10, and 9. On the bottom, start with the size of the smaller group and count down: 4, 3, 2, and 1. Cancel the numbers on the bottom, and the numbers on top will multiply to 495.
6. 660 The order of entrees the guests chose from does not matter. Therefore, the number of different possibilities of entrees is $\frac{12 \times 11 \times 10}{3 \times 2 \times 1} = 220$. The order of desserts does not matter either, so there are $\frac{3 \times 2}{2} = 3$ possible different combinations of desserts. Multiplying the two together gives a total of 660 possible different combinations of offerings.
7. C and E
This problem is about permutations, because the order of the figurines matter since they each look unique. You have two cases to consider here. Start with the option that Margaret buys three witches and three ghosts. In that case, she has 3 choices of witch for the first spot, 3 choices of ghost for the second spot, 2 choices of witch for the third spot, 2 choices of ghost for the fourth spot, 1 choice of witch for the fifth spot, and 1 choice of ghost for the sixth spot: Hence, her total number of arrangements is $3 \times 3 \times 2 \times 2 \times 1 \times 1 = 36$, which is choice (C). If she buys four of each figurine, her number of arrangements is $4 \times 4 \times 3 \times 3 \times 2 \times 2 \times 1 \times 1 = 576$, choice (E).
8. E The order of cars matters, so you simply need to multiply the number of possible cars for each spot. For the first car, there are six possible, for the second, five, and so on. So your scratch paper should look like this: $\underline{6} \underline{5} \underline{4} \underline{3} \underline{2} \underline{1}$, which is equivalent to $6!$, or 720.
9. A, B The order of friends doesn't matter. There are five friends to choose from for three spots, so the top of your fraction should read: $\underline{5} \underline{4} \underline{3}$, and to correct for the order of friends not mattering, the bottom of your fraction should be: $\underline{3} \underline{2} \underline{1}$. $\frac{5 \times 4 \times 3}{3 \times 2 \times 1} = 10$. Since he is numbering possibilities sequentially, the numbers 1 through 10 will be on the list, making choices (A) and (B) correct.
10. 1,320 In this case, order matters, so you simply need to multiply the number of possible runners for each spot. That should look like this: $\underline{12} \underline{11} \underline{10} = 1,320$.
11. A, B, and D
Starting with choice (A), there are 3 slots on the team, with 5 experienced engineers available for the first slot, 4 for the second slot, and 3 for the third slot. Order doesn't matter, so divide by $3!$ to get $\frac{5 \times 4 \times 3}{3 \times 2 \times 1} = 10$. Choice (A) is correct. For choice (B), you have 3 apprentice engineers available for 2 slots and once again, order doesn't matter. $\frac{3 \times 2}{1 \times 2} = 3$. Choice (B) is correct and you can eliminate

choice (C), which contradicts choice (B). For choice (D) you have $\frac{5 \times 4}{1 \times 2} = 10$, so choice (D) is correct. Choice (E) is incorrect because

$\frac{5 \times 4 \times 3 \times 2}{1 \times 2 \times 3 \times 4} = 5$. The correct answers are choices (A), (B), and (D).

12. B This is a permutation problem, so lay out your slots to fill and then multiply. For choice (A) you have 1 slot for a letter and two slots for digits. There are 26 choices for your letter and 10 choices for your first digit. Because you can't repeat digits, there are 9 choices for your second digit. Thus, the number of different codes that can be made is $26 \times 10 \times 9 = 2,340$. Eliminate choice (A). For correct choice (B), you have two spots for letters and two for digits, so you have 26×26 (letters can repeat) $\times 10 \times 9 = 60,840$. Choice (C) is incorrect because the number of different codes consisting of one letter and one digit is $26 \times 10 = 260$. The only correct answer is choice (B).
13. A, B, C, E, F, and G
Rather than writing out every possible outcome, see if you can express the answer choices as the product of 3 factors that could be the number of ties, shirts, and jackets Brian receives. Choice (A) is possible: $3 \text{ ties} \times 2 \text{ shirts} \times 1 \text{ jacket} = 6$ outfits. Choice (B) is possible: $4 \text{ ties} \times 2 \text{ shirts} \times 1 \text{ jacket} = 8$ outfits. Choice (C) is possible: $3 \text{ ties} \times 3 \text{ shirts} \times 1 \text{ jacket} = 9$ outfits. Choice (D) is not possible: you'd need a 5 as a factor to get to 10, and Brian can't receive 5 of anything, so eliminate choice (D). Choice (E) is possible in 2 different ways: $3 \text{ ties} \times 2 \text{ shirts} \times 2 \text{ jackets} = 12$ outfits, as does $4 \text{ ties} \times 3 \text{ shirts} \times 1 \text{ jacket}$. Choice (F) is possible: $4 \text{ ties} \times 2 \text{ shirts} \times 2 \text{ jackets} = 16$ outfits. And, finally, choice (G) is possible: $3 \text{ ties} \times 3 \text{ shirts} \times 2 \text{ jackets} = 18$ outfits. All of the choices except choice (D) work.
14. 56 This problem involves permutations, because the order matters since the ties are all distinct. Start with Paul wearing a red tie. He has 3 red tie choices and Allen has 2 remaining red tie choices, giving them a product of 6 permutations. For green ties, they have $5 \times 4 = 20$ permutations. For blue ties, they have $6 \times 5 = 30$ permutations. The grand total is 56 permutations



Coordinate Geometry

POINTS AND AREAS

A coordinate plane is simply any flat surface (a piece of paper, a chalkboard) that has been divided up into coordinates. The quadrants are as shown below.

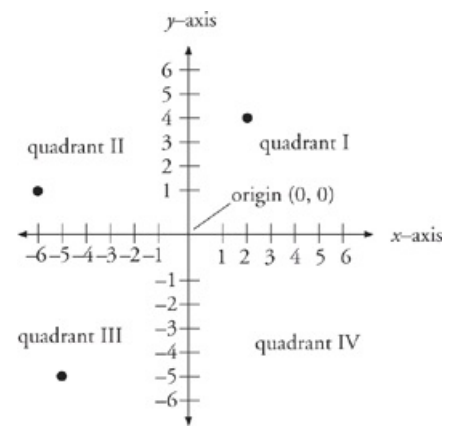

Some coordinate geometry problems will ask you to find the distance between points or the area of the shapes you make when you connect points. When plotting points on a graph, it is helpful to write the coordinates along the axis. This will turn the axis into number lines and make it easier to find the distances between points.

Here is an example.

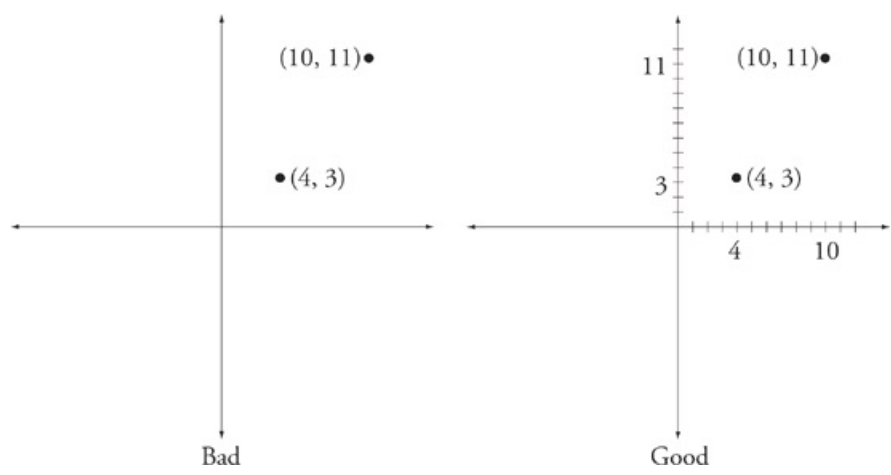

When you are asked to find the distance between these two points, you can use the distance formula or you can simply draw in a right triangle and use the Pythagorean theorem.

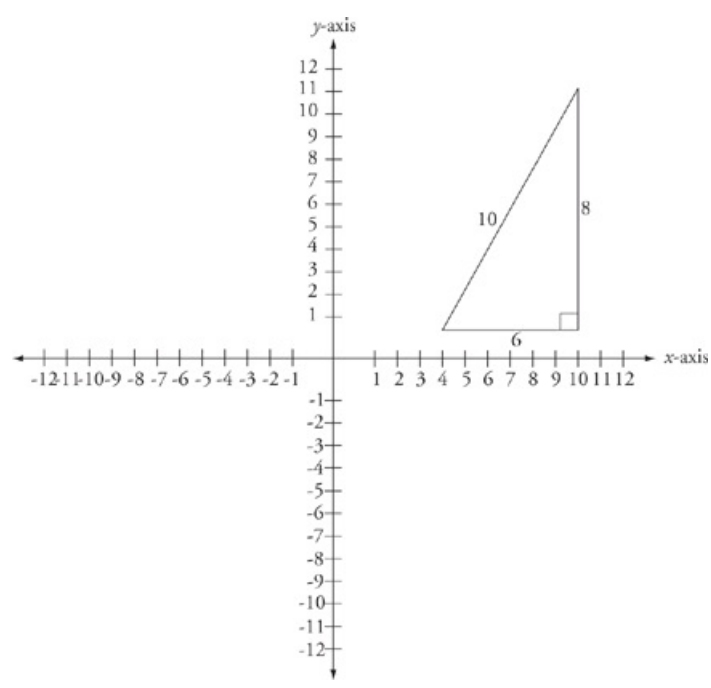

What would normally involve a long formula, and some calculations with the distance formula, becomes a simple process with a triangle, especially if it is a special right triangle. If you are finding the areas of shapes, they are the same old triangles, circles, and rectangles you find elsewhere on the test. The same rules apply. No matter what you are asked to find, it is still a geometry question, and you should still use your five steps.

Step 1

Step 1: Draw your shape

In some cases the test will give you a shape, which you may or may not be able to trust, or it will give you a word problem and leave it up to you to envision the shape. As with every other part of the test, getting your hand moving is an important first step to beginning the problem. Get your shape down on your scratch paper so that you can begin working with it there. On Quant Comp questions involving geometry, instead of Plugging In more than once, you may have to draw your shape more than once.

Step 2

Step 2: Fill in what you know

Whether you are given the shape or not, you will be given a certain amount of information regarding your shape such as the measure of some angles, lengths of some sides, area of some sides, or volume. Fill in what you know.

Step 3

Step 3: Make deductions

If you are given two angles of a triangle, find the third. If you are given the radius, find the area. Often this will be the entire problem. Geometry on the GRE is all about finding the missing piece of information. You will be given just enough information to find the piece that is missing.

Step 4

Step 4: Write down relevant formulas

If step three didn't get you the answer, you must still be missing a piece of information. Writing down the relevant formulas is a way of both organizing your information and figuring out what is missing. When you write your formulas down, fill in the information you have directly underneath the relevant part of the formula. It seems simple, but this way you can't make a mistake, and finding the missing piece of information becomes a simple case of solving for x .

Step 5

Step 5: Drop heights/draw lines

If you're still stuck, you may need to manipulate or subdivide your shapes. If you have triangles, draw in the height. Have you created a 30-60-90? A 45-45-90? Or a Pythagorean triple? Try subdividing the shape or, if it's a three-dimensional figure, dashing in the hidden lines.

LINES AND SLOPES

You might see a question that asks about slope or gives the formula for a line. Questions about slope are terrific for Ballparking. Sometimes you can eliminate two or even three answer choices just by knowing the difference between a positive and negative slope.

Here's the difference.

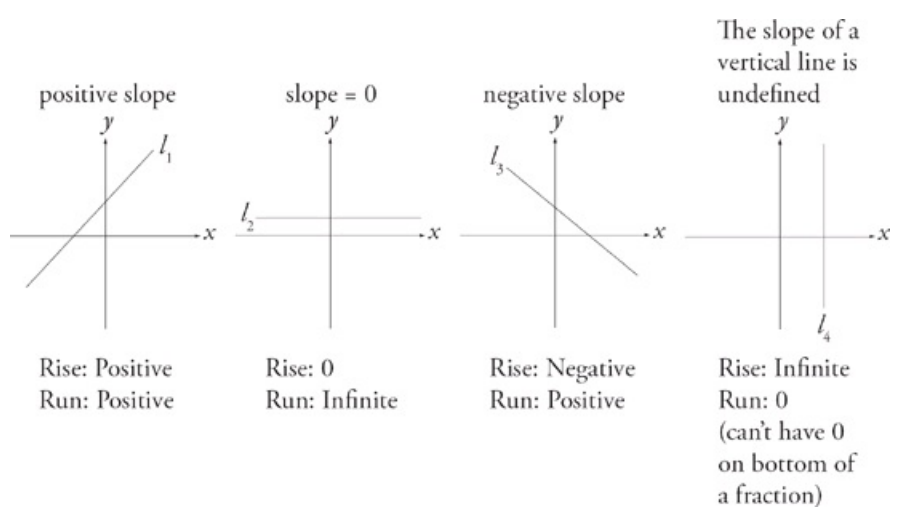

Slope is defined as $\frac{\text{rise}}{\text{run}}$ or $\frac{y_2 - y_1}{x_2 - x_1}$. If you had a line that went up 1 every time it went over 1, it would look the image shown below.

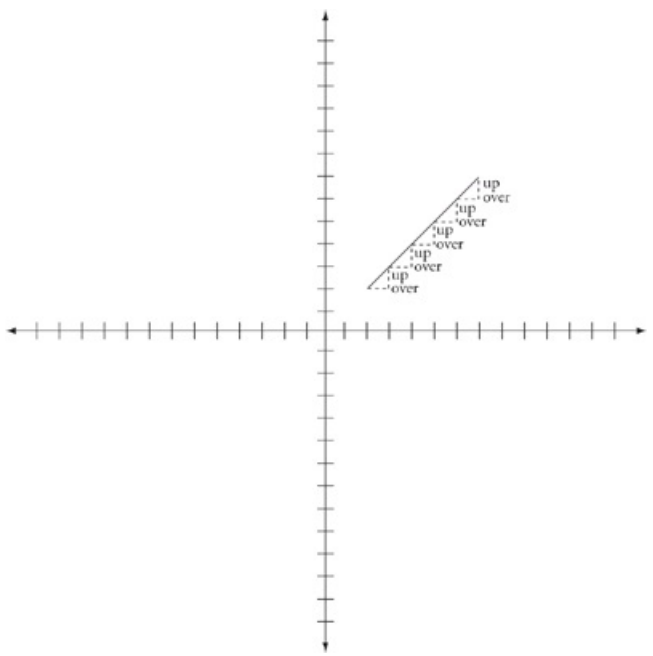

The slope is equal to one $\left(\frac{1}{1}\right)$, and the line lies at a 45 degree angle to the x-axis.

If you had a line that went up 2 every time it went over 1, it would look like the image shown below.

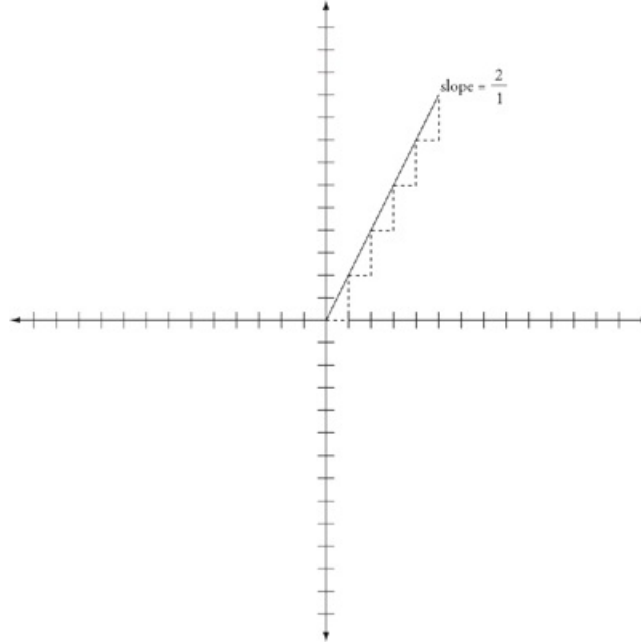

The slope of this line is $\frac{2}{1}$ or 2. Notice that the numerical value for the slope goes up as the line gets steeper. The opposite is also true. If you had a line that went over 2 every time went up 1, it would look like the image shown below.

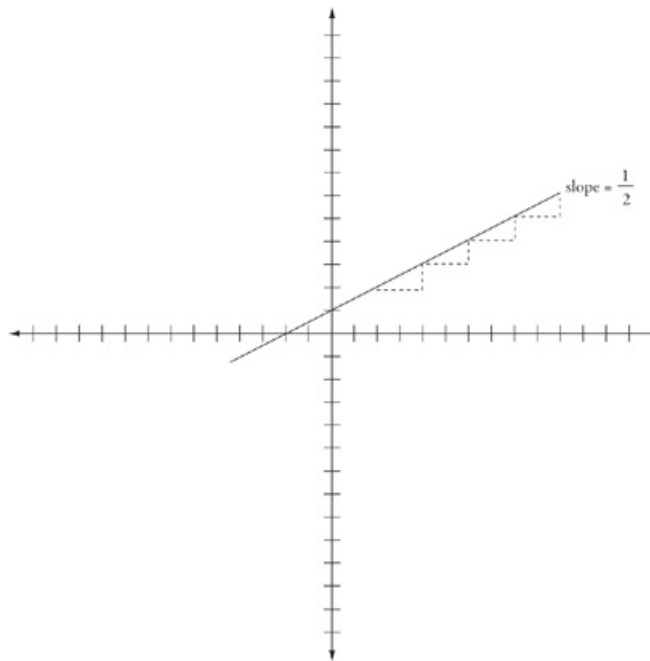

In this case, the slope is $\frac{1}{2}$ and you have shallower angle.

A line at less than a 45 degree angle will have a slope with an absolute value of 0 and 1. A line that intersects the x-axis at greater than 45 degrees will have a slope with an absolute value greater than 1.

The formula for a line is $y = mx + b$. x and y are the coordinates of a single point. b tells you where the line intersects the y -axis. m (or whatever value is being multiplied by x) tells you the slope of the line. With this information, you can accurately draw any line on a graph. ETS is likely to give you some of the information in this equation, sometimes as a picture, sometimes as a pair of points, or sometimes as an equation, and ask you to find the rest.

Remember three things.

1. With any two points you can find the slope.
2. The coordinates of the origin are $(0, 0)$. This is a point like any other and often the second point you need to find slope.
3. If you are given information as an equation, put it in the $y = mx + b$ format.

For example, you might be told that line l passes through the origin, and the coordinates of point A are $(7, 4)$.

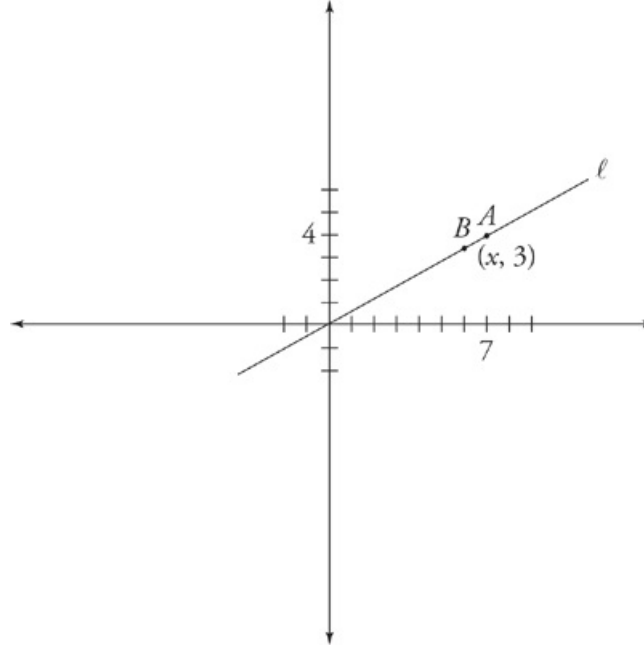

If you are asked to find the value of x at point B , draw it on your scratch paper like this.

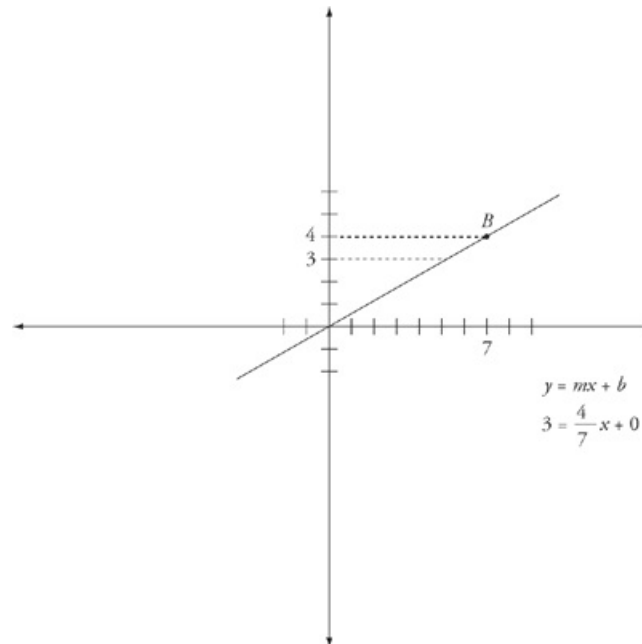

When you take the time to draw your shape carefully and accurately, usually you can immediately eliminate some answer choices just by Ballparking; you'll get some sense of the range of the correct answer. In this case, anything more than 7 is certainly going to be wrong, as is anything less than 4.

On your scratch paper, write out your formula and fill in the information you have directly underneath it.

You have been given the y -coordinate, 3. You know that the line goes up four for every 7 it goes over, so the slope is $\frac{4}{7}$. You also know that the line passes through the origin, so the y -intercept is 0. From here on out, you have a basic formula with one variable, $3 = \frac{4}{7}x + 0$. Simply solve for x . The answer is $5\frac{1}{7}$.

For more practice and a more in-depth look at The Princeton Review math techniques, check out our student-friendly guidebook, *Cracking the New GRE*.

DRILL 1

Question 1

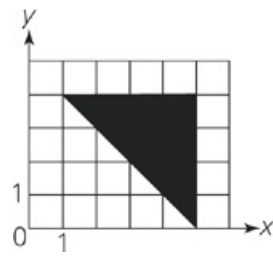

Quantity A

The area of the shaded region in Figure A

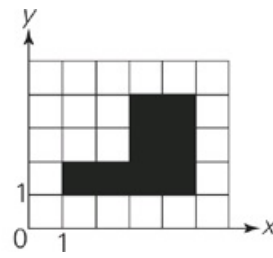

Quantity B

The area of the shaded region in Figure B

- Quantity A is greater.
- Quantity B is greater.
- The two quantities are equal.
- The relationship cannot be determined from the information given.

Question 2

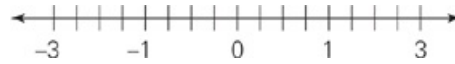

On the number line shown above, the coordinates of points P and Q are $-\frac{4}{3}$ and 2, respectively.

Quantity A

$$\frac{1}{2}$$

Quantity B

The coordinate of the midpoint of line segment PQ

- Quantity A is greater.
- Quantity B is greater.
- The two quantities are equal.
- The relationship cannot be determined from the information given.

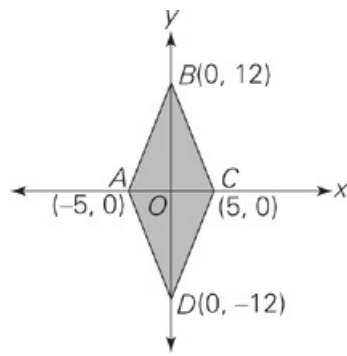

Quantity A

The perimeter of quadrilateral ABCD

Quantity B

The area of the shaded region

- Quantity A is greater.
- Quantity B is greater.
- The two quantities are equal.
- The relationship cannot be determined from the information given.

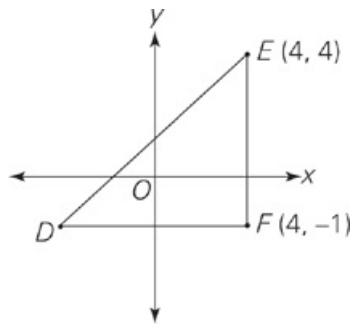

In the rectangular coordinate system above, if the area of right triangle DEF is 15, then which of the following are the coordinates of point D ?

- (−4, −1)
- (−2, −1)
- (−2, 4)
- (1, −1)
- It cannot be determined from the information given.

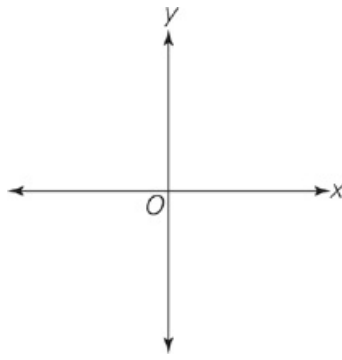

On the coordinate axes shown above, the graph of $y = 4x + 20$ would cross the x-axis at the point where

- $x = -5$ and $y = 0$
- $x = 0$ and $y = -5$
- $x = 0$ and $y = 5$
- $x = 0$ and $y = 20$
- $x = 5$ and $y = 0$

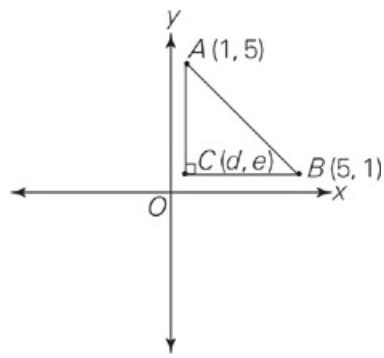

Line segment BC is parallel to the x-axis.

Line segment AC is parallel to the y-axis.

Quantity A

d

Quantity B

e

- Quantity A is greater.
- Quantity B is greater.
- The two quantities are equal.
- The relationship cannot be determined from the information given.

Cam's home is 2 miles east and 3 miles north of Atlanta. He drives to town B, which is 3 miles east and 9 miles north of his home.

Quantity A

Quantity B

The shortest distance between town B and Atlanta

17 miles

- Quantity A is greater.
- Quantity B is greater.
- The two quantities are equal.
- The relationship cannot be determined from the information given.

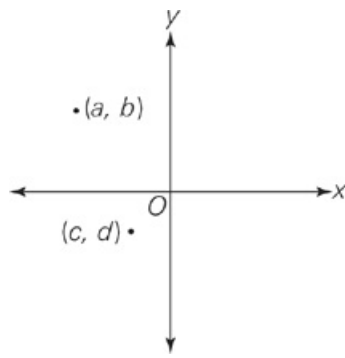

Quantity A

bd

Quantity B

ac

- Quantity A is greater.
- Quantity B is greater.
- The two quantities are equal.
- The relationship cannot be determined from the information given.

Which of the following is the graph of the equation $y = -|-x|$?

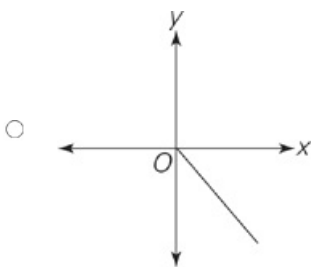
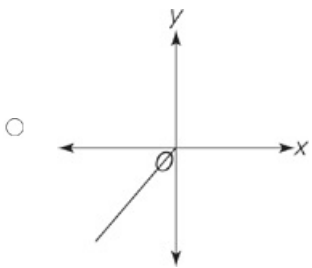
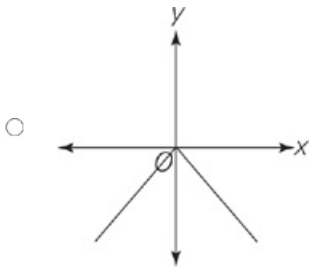
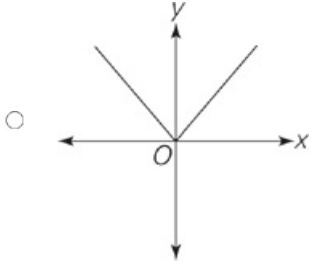
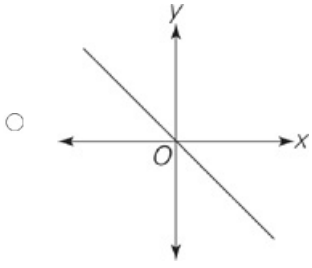

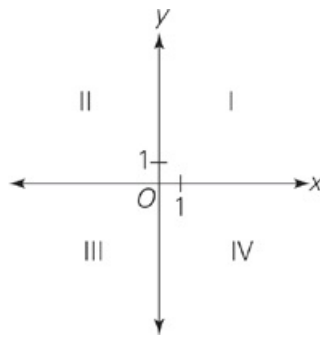

Points (a, b) and (c, d) , not shown in the figure above, are in quadrants I and III, respectively. If $abcd \neq 0$, then the point $(-bd, bc)$ must be in which quadrant?

- I
- II
- III
- IV
- It cannot be determined from the information given.

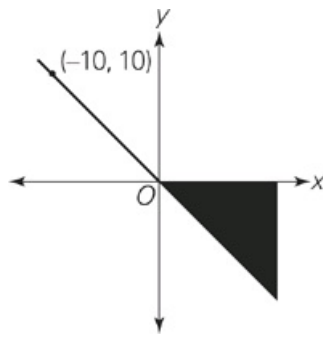

Which of the following pairs of coordinates corresponds to a point in the shaded region of the graph shown above?

- (9, -7)
- (-9, -7)
- (9, 7)
- (7, -9)
- (-7, -9)

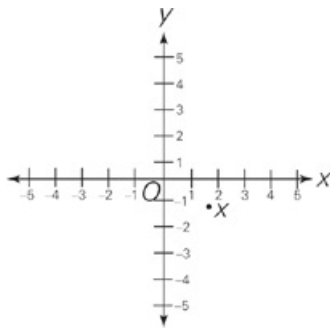

Point X is at (a, b) .

Quantity A

$-a$

Quantity B

b

- Quantity A is greater.
- Quantity B is greater.
- The two quantities are equal.
- The relationship cannot be determined from the information given.

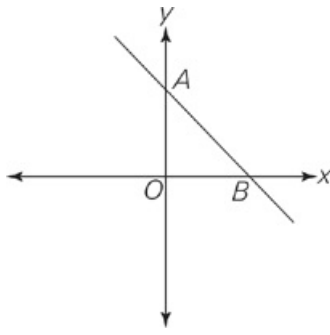

The equation of the line graphed on the rectangular coordinate system above is given by:

$$y = -\frac{13}{12}x + 8$$

Quantity A

AO

Quantity B

BO

- Quantity A is greater.
- Quantity B is greater.
- The two quantities are equal.
- The relationship cannot be determined from the information given.

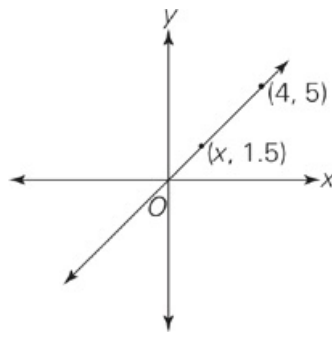

What is the value of x in the rectangular coordinate system above?

- 1.0
- 1.2
- 1.4
- 1.6
- 1.8

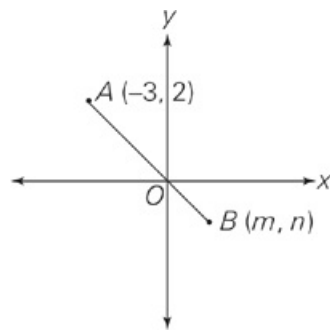

Quantity A

$-m$

Quantity B

n

- Quantity A is greater.
- Quantity B is greater.
- The two quantities are equal.
- The relationship cannot be determined from the information given.

If the x-coordinates of the two x-intercepts of a parabola are $3-\sqrt{2}$ and $5+\sqrt{2}$, then what is the distance between them?

- $2-2\sqrt{2}$
- $2+2\sqrt{2}$
- $8+2\sqrt{2}$
- 2
- 8

DRILL 2

Question 1

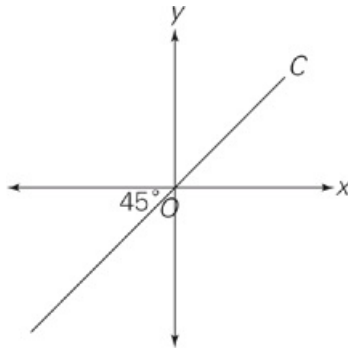

Point D (not shown) lies below line C in the rectangular coordinate system above.

Quantity A

The x-coordinate of point D

Quantity B

The y-coordinate of point D

- Quantity A is greater.
- Quantity B is greater.
- The two quantities are equal.
- The relationship cannot be determined from the information given.

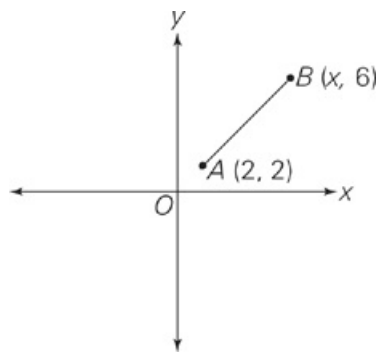

In the coordinate system above, the slope of line segment AB is $\frac{4}{3}$.

Quantity A

The length of line segment AB

Quantity B

x

- Quantity A is greater.
- Quantity B is greater.
- The two quantities are equal.
- The relationship cannot be determined from the information given.

In the rectangular coordinate plane, the coordinates of points A, B, and C are $(1, 4)$, $(7, 4 + 6\sqrt{3})$ and $(7, 4)$, respectively. What is the absolute value of the difference between AB and BC ?

- 6
- $4 + \sqrt{3}$
- $6 - 6\sqrt{3}$
- $6\sqrt{3} - 12$
- $12 - 6\sqrt{3}$

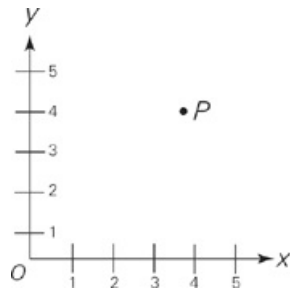

Point Z (not shown) lies inside the circle with center P and radius 2 (also not shown).

Quantity A

The x-coordinate of point Z

Quantity B

The y-coordinate of point Z

- Quantity A is greater.
- Quantity B is greater.
- The two quantities are equal.
- The relationship cannot be determined from the information given.

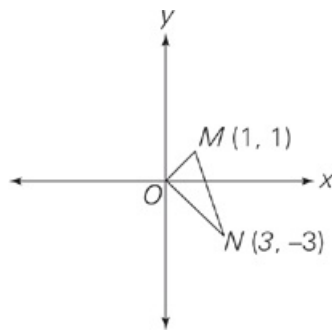

What is the area of triangle MNO in the figure above?

- 3
- 6
- $4\sqrt{2} + 2\sqrt{5}$
- $2\sqrt{10}$
- $6\sqrt{10}$

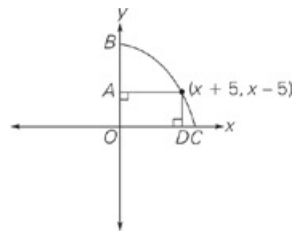

In the figure above, if BC is an arc in the circle with center O , then $AB - DC =$

- -10
- 10
- $2x$
- $x^2 - 25$
- $\sqrt{2x^2 + 50}$

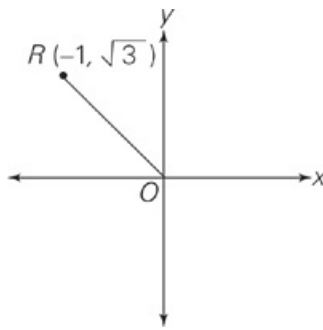

In the coordinate system above, line segment OR is rotated clockwise through an angle of 120° to position OS (not shown).

Quantity A

The x-coordinate of point S

Quantity B

$\sqrt{3}$

- Quantity A is greater.
- Quantity B is greater.
- The two quantities are equal.
- The relationship cannot be determined from the information given.

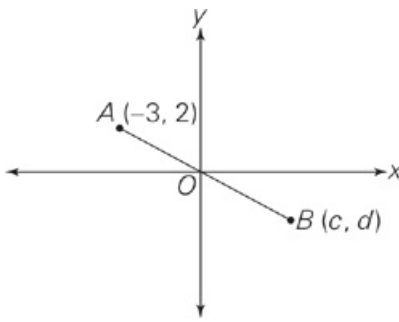

Line AB passes through the origin. If $2 < c < 10$, which of the following could be possible values for d ?

Indicate all possible values.

- 2.0
- 1.3
- 1.8
- 3.1
- 5.5
- 6.8
- 10.0

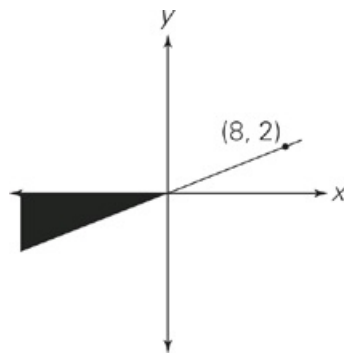

Which of the following points are located in the shaded region of the graph above?

Indicate all possible values.

- (6, 1)
- (-4, 0.5)
- (-4, -0.5)
- (-4, -4)
- (-6, 1)
- (-6, -1)
- (-6, -2)

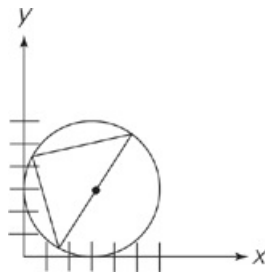

The above circle's circumference includes points $(0, 3)$ and $(3, 0)$, and the base of the inscribed isosceles triangle passes through the center of the circle. What is the area of the triangle?

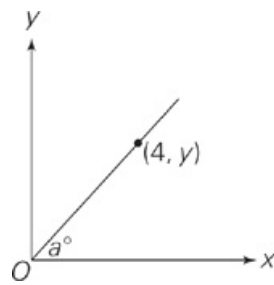

If angle a can range from 45° to 60° , which of the following are possible values for y ?

Indicate all possible values.

- 2
- 3
- 4
- 5
- 6
- 7
- 8

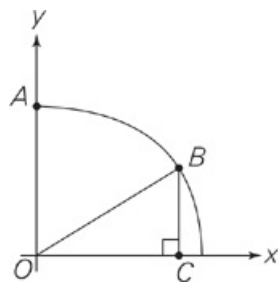

If point A is at $(0, 8)$, point C is at $(6, 0)$, and the distance from point B to point C is x , what is $\frac{x}{\sqrt{7}}$?

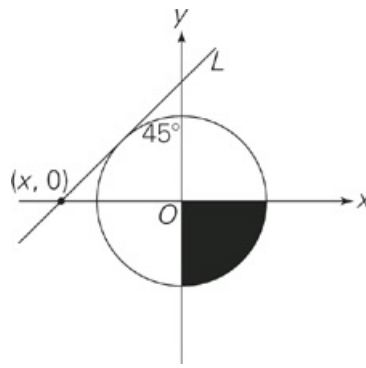

In the figure above, line L is tangent to the circle, which is centered at the origin. The area of the shaded region is equal to the circumference of a circle with radius between 1 and $2\frac{1}{4}$. Which of the following could be values of x ?

Indicate all possible values.

- 2
- 3
- 4
- 6
- 8.5
- 12

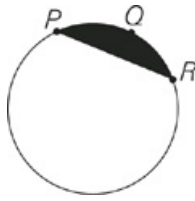

In the figure above, the circumference of the circle is equal to 8π , and arc PQR is equal to $\frac{1}{4}$ of the total circumference. What is the approximate area of the shaded region? (Round your answer to the nearest whole number.)

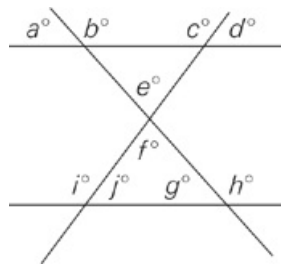

In the figure above, if $a = g$, which of the following must be true?

Indicate all possible values.

- $e = f$
- $i = d$
- $e = 90$
- $c + d = 180$
- $i + h = 180$
- $a + d + f = 180$
- $180 - i - h + e = 0$

ANSWERS

Drill 1

1. C
2. A
3. B
4. B
5. A
6. C
7. B
8. B
9. C
10. D
11. A
12. B
13. A
14. B
15. B
16. B

Drill 2

1. A
2. C
3. E
4. D
5. A
6. B
7. A
8. C, D, E
9. C, F
10. 9
11. C, D, E
12. 2
13. D
14. 4
15. A, D, F, G

Drill 1

- C Figure A contains 6 whole boxes plus 4 half-boxes, for a total of 8. Figure B contains 8 whole boxes. The answer is choice (C).

Alternatively, the area of the right triangle in Figure A is $\frac{1}{2}bh = \frac{1}{2}(4)(4) = 8$ and Figure B contains a rectangle plus two units whose total area is $bh = (3)(2) = 6; 6 + 2 = 8$.
- A The distance between P and Q is $6\frac{2}{3}$ ticks, so the midpoint will be $3\frac{1}{2}$ ticks from either endpoint, which is the first tick to the right of 0, at $\frac{1}{3}$. To find the coordinate of the midpoint, simply average the coordinates of the endpoints: $\frac{-\frac{4}{3} + 2}{2} = \frac{\frac{2}{3}}{2} = \frac{1}{3}$. so Quantity A is greater. Alternatively, because the smaller ticks divide each unit into 3 equal parts, they represent lengths of $\frac{1}{3}$.
- B The axes split the quadrilateral into four equal 5-12-13 right triangles (note the highly suspicious numbers on the drawing). So the perimeter is $4(13) = 52$, and Quantity B is therefore greater.
- B Subtracting the y-coordinates of the given points gives you the length of leg EF: $4 - (-1) = 5$. The area formula for a triangle will give you the length of the other leg, DF: $\frac{1}{2}bh = \frac{1}{2}(b)(5); b = 6$, which equals 15. Subtracting 6 from the x-coordinate of F gives you the x-coordinate of D, and D has the same y-coordinate as F. So the coordinates of D are $(-2, -1)$; the answer is choice (B).
- A On the x-axis, $y = 0$; eliminate choices (B), (C), and (D). Then plug in 0 for y in the given equation. Solve for x: $0 = 4x + 20$, so $x = -5$, and the answer is choice (A).
- C Point C has the same x-coordinate as point A and the same y-coordinate as point B. The coordinates of C are therefore $(1, 1)$, so the quantities are equal.
- B Draw a rectangular coordinate system with Atlanta as the origin, i.e., the point $(0, 0)$. So Cam's home is at $(2, 3)$. Going 3 miles east and 9 miles north puts town B at $(5, 12)$. Quantity A is the straight line distance from $(0, 0)$ to $(5, 12)$. Connecting these two points creates the hypotenuse of a 5-12-13 right triangle, so Quantity A is 13, and the answer is choice (B).
- B Point (a, b) is in the second quadrant where points have signs of $(-, +)$; thus, a is negative and b is positive. Point (c, d) is in the third quadrant where points have signs of $(-, -)$; thus, c is negative and d is negative. So, Quantity A is a positive times a negative, which is negative. Quantity B is a negative times a negative, which is positive. Quantity B must be greater.
- C Plug values into the equation and eliminate graphs that do not include those values. If $x = 1$, then $y = -1$; eliminate choices (B) and (D). If $x = -1$, then $y = -1$, eliminate choices (A) and (E). Only choice (C) remains.
- D Plug in points in the appropriate quadrants. If $(a, b) = (1, 2)$ and $(c, d) = (-3, -4)$, then the point in question is $(-bd, bc) = [-(2)(-4), (2)(-3)] = (8, -6)$, which is in quadrant IV; the answer is choice (D).
- A Use Process of Elimination to solve this one. First, only coordinate pairs with a positive x-value and a negative y-value will fall in the proper quadrant, so eliminate choices (B), (C), and (E). The line that divides the correct quadrant into shaded and unshaded regions has a slope of -1 because it goes through the origin and the point $(-10, 10)$. On this line, the absolute value of the x-coordinate equals the absolute value of the y-coordinate. In the shaded region, then, $|x| > |y|$, so choice (D) can be eliminated. Only choice (A) remains. Alternatively, realize that this figure is drawn accurately, because of the placement of $(10, -10)$, and plot all 5 points, eliminating all of those that fall outside the shaded region.
- B Point X is at approximately $(2, -1.5)$. So Quantity A is about -2 and Quantity B is about -1.5 , thus, Quantity B is greater.
- A Although you have enough information to find the exact values of AO and BO, it's not necessary to do so to compare the quantities. The slope of the line is $-\frac{13}{12}$, which means that the vertical distance, or rise, is greater than the horizontal distance, or run, by a ratio of 13 to 12 (you're dealing with distances on a coordinate plane, so disregard the negative sign). Because AO and BO are equal to, respectively, the rise and the run of the same segment of the line, Quantity A is greater.

that slope is change in y over change in x. Thus, $\frac{5-0}{4-0} = \frac{1.5-0}{x-0}$, or $\frac{5}{4} = \frac{1.5}{x}$. Cross-multiply to find $5x = 6.0$. Divide by 5 to find $x = 1.2$. The answer is choice (B).

1.2. The answer is choice (B).

15. B Just because you don't know the values of $-m$ and n doesn't mean you can't determine which is greater. Using point A and the origin, you can find the slope of segment AB: $\frac{\text{rise}}{\text{run}} = \frac{-2}{3} = -\frac{2}{3}$. Now plug in coordinates for point B that will give you the same slope; the easiest way to pick them would be to simply rise -2 and run 3 , bringing you to the point $(m, n) = (3, -2)$. So $-m = -3$, and $n = -2$, and Quantity B is greater.

16. B You don't need to use the distance formula, because the distance between the points $(3-\sqrt{2}, 0)$ and $(5+\sqrt{2}, 0)$ can be measured horizontally. Distance is positive, so subtract the smaller x-coordinate from the larger: $(5+\sqrt{2}) - (3-\sqrt{2}) = 2+2\sqrt{2}$; the answer is choice (B).

1. A Plug in a few points that lie below line c, such as (0, -1), (-3, -4), (1, 0). In each case, the x-coordinate is greater than the y-coordinate, so Quantity A is greater. Alternatively, realize that the 45 degree angle and the fact that the line passes through the origin tells us that the equation of line c is $y = x$. So the region below the line is the graph of $y < x$. The coordinates of all points in that region must satisfy the inequality.
2. C Break this one into bite-sized pieces: You need x in order to find the length of AB, so find x first. If you insert the given values into the slope formula, $\frac{y_2 - y_1}{x_2 - x_1}$, you get $\frac{6 - 2}{x - 2} = \frac{4}{3}$, so $x = 5$. Now you need to find the length of AB. Rather than using the distance formula, turn AB into the hypotenuse of a right triangle and find the lengths of the other sides. To make the triangle, add a new vertex at coordinate (5, 2): The length of the horizontal leg is $5 - 2 = 3$, and that of the vertical leg is $6 - 2 = 4$, yielding the familiar 3-4-5 triangle. The length of segment AB = 5, so the two quantities are equal.
3. E Draw the points and connect the points to form a right triangle. Subtract the x-coordinate of A from that of C to find the length of AC: $7 - 1 = 6$. Subtract the y-coordinate of C from that of B to find the length of BC: $4 + 6\sqrt{3} - 4 = 6\sqrt{3}$. Notice that the ratio of AC to BC is 1 to $\sqrt{3}$. Therefore, ABC is a 30-60-90 triangle, and the length of AB, the hypotenuse, will be double the length of the shorter side (6), so $AB = 12$. The absolute value of the difference will be the positive value, obtained by subtracting the smaller value (BC) from the larger value (the length of the hypotenuse, AB): $AB - BC = 12 - 6\sqrt{3}$, which is choice (E).
4. D Plug in points. Points (3, 4) and (5, 4) both lie inside the circle, so different values give different outcomes.
5. A The slope of MO is 1, so it makes a 45 degree angle with the positive x-axis. Similarly, the slope of NO is -1, so it makes another 45 degree angle with the positive x-axis. The sum of the degree measures of these angles is 90, so MNO is a right triangle. Therefore, MO and NO are the base and height of triangle MNO. To find the area of the triangle, you need to find the length of MO and NO. Drop a perpendicular from point M to the y-axis, to form an isosceles right triangle whose hypotenuse is MO. Each leg of this triangle has length 1 so, $MO = \sqrt{2}$. Similarly, dropping a perpendicular line from the y-axis to point N creates another isosceles right triangle, whose legs have length 3, and whose hypotenuse is NO. Therefore, $NO = 3\sqrt{2}$. So the area of triangle MNO is $\frac{1}{2}bh = \frac{1}{2}(\sqrt{2})(3\sqrt{2}) = 3$, and the answer is choice (A).
6. B To find AB, find the radius of the circle and then subtract OA. If the radius is r, then $AB = r - (x - 5) = r - x + 5$. Similarly, $DC = r - (x + 5) = r - x - 5$. So $AB - DC = [r - x + 5] - [r - x - 5] = 10$, so the answer is choice (B). If you use POE, you can eliminate choice (A) because you know the answer has to be positive. If you selected choice (E), you selected the radius.
7. A Drawing a horizontal line from point R to the positive y-axis forms a right triangle. The length of the leg that sits on the y-axis is $\sqrt{3}$, and the horizontal leg you just drew has length 1. The ratio of the legs is 1 to $\sqrt{3}$, so you have a 30-60-90 right triangle. Therefore, the hypotenuse (OR) has length 2, and the angle between OR and the positive y-axis is 30 degrees. The first quadrant includes 90 degrees total, so rotating OR 120 degrees clockwise puts OS on the positive x-axis, with a length of 2. Therefore, the x-coordinate of OS is 2, which is slightly larger than $\sqrt{3}$, which is approximately 1.7. The answer is choice (A).
8. C, D, and E
 First, find the slope of the line, which runs through (-3, 2) and (0, 0). The slope is the change in y over the change in x, or $-\frac{2}{3}$.
 Therefore, the equation of line AB is $y = -\frac{2}{3}x$. To find the range of possible values for d, plug in the given range of possible values for c to the equation. If $c = 2$, $d = -\frac{4}{3}$, and if $c = 10$, $d = -\frac{20}{3}$. Any value between $-\frac{4}{3}$ and $-\frac{20}{3}$, or -1.33 and -6.67, will work for d. Therefore, the only right answers are choices (C), (D), and (E).
9. C and F
 First, find the equation of the line that defines the shaded region, expressed as $y = mx + b$, Using the origin and the one given point

in the diagram, the slope m equals $\frac{1}{4}$, and the y -intercept b is 0. So $y = \frac{1}{4}x$ is the boundary line. Looking at the figure, if either x or y are positive, then the point isn't in the shaded region; you can eliminate choices (A), (B), and (E). For the other choices, plug in the x -values. If the resulting y -value is less than the y -value in the choice, that point lies below the line and outside the shaded region. So you're looking for points for which $y \geq \frac{1}{4}x$, when $x \leq 0$. This is true for correct choices (C) and (F).

10. 9 The circle touches (0, 3) and (3, 0), so its center must be at (3, 3) and its radius must be 3. Since the base of triangle passes through the center of the circle, the base of the triangle must be the diameter of length 6. Given the triangle is isosceles and inscribed within the circle, a line from the circle's center to the triangle's corner equals the triangle's height. This height must be the radius of the circle. The area of a triangle is $0.5 \times \text{base} \times \text{height}$: $0.5 \times 6 \times 3 = 9$.

11. C, D and E
Given that the angle ranges from 45° to 60° , you need to plug in values for angle a and find a special triangle to solve for y . If a is 45° , the triangle's sides are $x, x, x\sqrt{2}$. It doesn't matter what the hypotenuse is; $x = 4$, which means y also is 4. If a is 60° , the triangle's sides are $x, x\sqrt{3}, 2x$. The shortest side of the triangle would be the one on the x -axis. Since $x = 4$, then $y = 4\sqrt{3} = 6.92$. So the correct answers range from 4 to 6.92. Choices (C), (D), and (E) are all correct.

12. 2 You need to find the length of a leg of a triangle. By finding the lengths of the two other sides, you can use the Pythagorean theorem to find the third side. The hypotenuse of the triangle is the radius of the (quarter-) circle, which, since point A is at (0, 8), is 8. Since point C is (6, 0), the other leg is 6. From the Pythagorean theorem, $6^2 + x^2 = 8^2$, so $x^2 = 28$, $x = \sqrt{28} = \sqrt{4 \times 7} = \sqrt{4} \times \sqrt{7} = 2 \times \sqrt{7}$, so $\frac{x}{\sqrt{7}} = 2$.

13. D Use line L to make a triangle, with points at (x, 0), the 45° angle, and the origin. The angle at (x, 0) must be 45° since the sum of the angles of a triangle is 180° . Since line L is tangential to the circle and forms 45° angles with each axis, a line from the point where line L and circle intersect to the origin will form a right angle with line L. The smaller triangle formed—from (x, 0), to where line L and circle meet, to the origin—will be a 45-45-90 triangle, with two sides equal to the radius of the circle. Find the radius of the circle, and you can find x . The area of the shaded region is equal to the circumference of a circle with radius between 1 and $2\frac{1}{4}$. Circumference = $2\pi r$, so the area of the shaded region is between 2π and 4.5π , which means the area of the circle in the figure is between 8π and 18π . Area = πr^2 , so the radius of the circle is between $\sqrt{8}$ and $\sqrt{18}$, which is to say between $2\sqrt{2}$ and $3\sqrt{2}$. 45-45-90 triangles have sides of $a-a-\sqrt{2}a$, where, in this case, a is between $2\sqrt{2}$ and $3\sqrt{2}$. So the hypotenuse of the triangle, from the origin to (x, 0), is between $2\sqrt{2}\sqrt{2}$ and $3\sqrt{2}\sqrt{2}$, and therefore between 4 and 6, so x can range from -4 to -6.

14. 4 From the information in the problem you know that $8\pi = 2\pi r$ and $r = 4$. The area of the circle is equal to πr^2 , so the area of the circle is 16π . If you draw one radius from the center O of the circle to point P, and another radius from O to point R, you know that the central angle formed will be 90 degrees because arc PQR equals $\frac{1}{4}$ of the total circle. The triangle formed by inserting these two radii will be an isosceles right triangle with sides of 4, 4, and $4\sqrt{2}$ and an area of 8. The total area taken up by the triangle and the shaded area together will be equal to 4π , or $\frac{1}{4}$ of the circle. The total area - the unshaded area = the shaded area you want, so the shaded area must equal $4\pi - 8$. The value of π can be rounded to approximately 3, so now you have $12 - 8 = 4$.

15. A, D, F, and G
Plug in for a . If $a = 40$, then $b = 140$, $g = 40$, and $h = 140$. Now plug in for c . If $c = 100$, then $d = 80$, $i = 100$, and $j = 80$. You know that g, j , and f must add up to 180, so $40 + 80 + f = 180$, which means that $f = 60$, which in turn means that $e = 60$. Now check your answer choices to see which ones are true. In this case $e = f$, so keep choice (A). However, $i \neq d$, so you can eliminate choices (B) and (C). Choice (C) is also not true and should be eliminated. $100 + 80 = 180$, so you cannot eliminate choice (D). $100 +$

140 \neq 180, so choice (E) is incorrect. $40 + 80 + 60 = 180$, so keep choice (F) for now. You have three answers and since this is a must be true question, you should try another set of numbers and test the three choices with the new values to see if the choices are still correct. Choices (A), (D), (F), and (G) are the correct answers.

Essays



There are two essays on the GRE. They care about your essay score. Unfortunately, very few programs care about your essay score. Before you spend time preparing for the essays, call the programs to which you plan to apply and ask them if they plan to look at your essay score. If they don't, skip this chapter. If your program is highly competitive, then all numbers count and you should keep reading.

The first of the GRE's two essays is the Issue essay. On this essay you will be given two topics, called prompts, from which to choose, and 30 minutes to craft and write your essay. You will be given a specific task to perform, but essentially your job is to formulate an opinion on one of those prompts and to support it with well-chosen examples. It's really more like a debate team exercise than a writing exercise. You need to craft the strongest argument you can, and you have 30 minutes in which to do it.

On the second essay you are the judge. You will be presented with someone else's argument, and it is your job to evaluate its strengths as an argument. Again, you will be given an argument and a specific assignment, but no matter what, you will have to be familiar with and evaluate the basic parts of an argument. It doesn't matter if you agree or disagree, only whether or not the argument is logically sound, and the issue is thoroughly considered and effectively presented.

Both of your essays will be scored on a six-point scale in half-point increments, and then the two scores will be averaged and rounded to the nearest half-point. If you score a 5 on one essay and a 6 on another, you will end up with a 5.5. A 5.5, by the way, puts you in the 87th percentile. You must score a 4.5 to put yourself above the 50th percentile or higher. Here is the breakdown of percentiles by score:

Score	Analytical Writing Percentile	Score	Analytical Writing Percentile
6	96	3	7
5.5	87	2.5	2
5	71	2	1
4.5	52	1.5	0
4	32	1	0
3.5	17	0.5	0

For both essays, it is critically important to consider the reader. ETS says that each reader will spend two minutes on your essay, but really, it's more like one. They call it "holistic grading" and claim that they consider the overall impact of the whole essay. You have a very short time to grab their attention, make a few strong points, and then wrap up. Your job is not to write the best essay ever. Not only do you not have enough time, but a beautifully written, crafted essay that takes a long time to develop and is full of deliciously subtle points may very well miss the mark. Your job is to give them what they're looking for, quickly and accessibly, so that they can give you the score you want.

Because this is a standardized test, it is not about opinion. It is not the reader's job to respond personally to your arguments or your opinions. In fact, they have a very specifically defined scoring rubric. They are looking at three things: the quality of your thinking, the quality of your organization, and the quality of your writing. Each one counts equally. All three must be present to some degree to score in the top half. An essay in the bottom half, scoring a 1, 2, or 3, will be missing one or more of these three components. It may be well structured but too narrow or obvious in its thinking. The thinking might be great, the writing pretty good, but organizationally it might be a disaster.

Since each of these three factors is so important, we want an approach that gives all three their due. No matter which essay you are working on, you must devote time to thinking, organizing, and writing.

THE ISSUE ESSAY

You will be given two prompts to consider. Each prompt will give a strongly worded point of view on some subject accessible to all. This means that they won't ask about Hamlet, but they might talk about education, society, or personal growth. Other topics could include anything from law, society, or trust to art, change, or technology. In fact ETS lists all of their topics on their website, www.ets.org. Go to GRE → General Test → Test Preparation → Writing Topics.

Here are some examples of the type of prompts you will see for your Issue essay:

Topic: Most people would agree that buildings represent a valuable record of any society's past, but controversy arises when old buildings stand on ground that modern planners feel could be better used for modern purposes. In such situations, modern development should be given precedence over the preservation of historic buildings so that contemporary needs can be served.

Instructions: Write a response in which you discuss the extent to which you agree or disagree with the statement. In developing your point of view, consider ways in which the statement might or might not hold true and explain how these considerations affect your point of view.

Topic: No one can possibly achieve success in the world by conforming to conventional practices and conventional ways of thinking.

Instructions: Write a response in which you discuss the extent to which you agree or disagree with the statement. In developing your point of view, be sure to consider and address opposing views to your position.

Topic: Students should memorize facts only after they have studied the ideas, trends, and concepts that help explain those facts. Students who have learned only facts have learned very little.

Instructions: Write a response in which you discuss the extent to which you agree or disagree with the statement. In developing your point of view, consider the effects of implementing a policy based upon the statement and how the effects impact your position.

The essay topics are fairly general in nature. Education, for example, means lots of different things to different people and you could take your essay in a number of different directions. One of the most common mistakes test takers make is to write the essay on the first three examples that come to mind (while sitting in a cubicle at the test center). These examples are not necessarily the best, the most interesting, or even within the writer's area of expertise. They also tend to be simplistic, similar, and often really obvious.

To avoid this trap, force yourself to spend time thinking. Specifically, use your scratch paper to make a chart. On one side write "I agree" and summarize the prompt. On the other side, write "I disagree" and summarize the opposing argument. Now force yourself to brainstorm four examples for each column. It's likely that you will have no trouble filling up one column, but you may struggle on the other. Push yourself to complete it. It is when you really push your thinking that your essay gets interesting.

If you run out of ideas during your brainstorm, use this simple checklist. Ask yourself, "How is this true for me, my family, children, the elderly, my school, my community, my employer, my state, my country, my species, nature, science, or history?" By using this checklist to generate examples, you will automatically begin to see the issue from multiple perspectives. This will add richness and depth to your thinking.

Of course, the examples you choose need to be good ones. The best place to start is with things you know. Think about your job, your life, or your major in school. Work from your areas of strength or expertise and the ideas will come more easily and be far more powerful. You might think that the Holocaust or Gandhi's march to the sea are perfect examples, but if you don't know much more than the basics about either topic, you run the risk of sounding trite and simplistic. No one wants to sound trite when talking about the Holocaust.

When you come up with a general example, make sure you always attach it to a specific. If the topic is education and your point is that it is necessary so that history does not repeat itself, get specific. Which history, whose education. A general essay is short and average. An essay that rests upon clearly defined examples is longer and far more convincing.

Yes, you can write the essay in the first person. It is your job to have an opinion on the subject and to express it.

Step 2—Organizing

Now that you have this great list of ideas and examples, it's time to craft an essay. At this point, do NOT pick a point of view. Pick your best three examples. The point of view is irrelevant; it is your examples that make your essay powerful. It doesn't matter if you pick examples from both sides of the agree/disagree divide. If you have examples from both sides, it simply means that you will disagree with the prompt and that your thesis statement will be some variation of: "this is often true but not always."

Rarely will you see a topic with which you agree wholeheartedly and for which you can't come up with a few powerful exceptions. In fact, an essay that acknowledges that there are two sides to an issue, and that take time to address some of the opposing points of view, will be far more powerful. Instead of saying, "You are wrong and I disagree," you are saying, "I understand your point of view; here's why I think my point of view is better." Which one gives your argument more authority?

Pick your best three examples. These will be the ones about which you know the most, about which you are the most excited, and which can be linked together in a common thread. You might choose three examples that could sit on either side of the agree/disagree divide depending upon the point of view. You might pick three different scales and show how the topic affects a child, a family, or a country. You might want examples from wildly different fields such as software development, literature, and psychology. If you have brainstormed well, you will have plenty of interesting things from which to choose.

Once you have three good examples, you can craft your thesis statement to accommodate your examples. This way your examples will appear to be perfectly selected to support your thesis. Isn't it nice to have the perfect examples ready just when you need them? Now, write your thesis statement out on your scratch paper. Another common mistake is for essay writers to lose the thread of their argument halfway through the essay, or to stray from their thesis statements. This happens when you fail to make a plan and stick to it. Most people are actively thinking about what they're going to write next while they're already writing! This causes all kinds of errors, oversights, and meandering essays. Don't do it.

Do not think about what you're going to write, while you're already writing. Make a plan before you start, and stick to it.

When you write out your thesis statement, you don't have to go into detail. You've got four more paragraphs with which to do that. Just tell the reader what you intend to prove and give him or her some sense of how you're going to do it. Your first paragraph will be short, to the point, and no more than three sentences. If your topic is censorship and your examples are spam parental controls on Internet portals, the dominance of a few major corporations in news production, and access to a free press in China, then that is all you need to say in your intro. You have plenty of time to get to specifics in your body paragraphs.

On your scratch paper, write out your thesis statement, your three examples, one or two words here will do, and then a few words to remind yourself why each example is proof of your thesis statement. You don't need a whole sentence, just a few words such as "children, Internet, some censorship—good" or "children, Internet—children too sheltered, don't learn to censor selves."

When you begin to write your essay, these little guidelines will become the topic sentences of each of your supporting paragraphs. They will ensure that your essay stays on track and that the job of each example is clear to the reader.

Writing

Now that you have three beautifully chosen examples, a point of view perfectly supported by the examples, an outline, and even your topic sentences, you are ready to write. In fact your essay, at this point, is 80 percent written. All you need to do is flesh out your paragraphs, come up with a conclusion, and you're done. The great thing about this is that it leaves you free to really focus on your writing.

ANALYSIS OF AN ARGUMENT

On the Issue essay, it was your job to craft your own Argument. On the argument essay, your job is the opposite. You will be given someone else's argument and it is your job to break it down and assess it. In some ways, this is not difficult. The argument you will be given will be filled with some pretty obvious flaws. Here are some examples:

The following appeared in a memorandum from the new president of the Patriot car manufacturing company.

In the past, the body styles of Patriot cars have been old-fashioned, and our cars have not sold as well as have our competitors' cars. But now, since many regions in this country report rapid increases in the numbers of newly licensed drivers, we should be able to increase our share of the market by selling cars to this growing population. Thus, we should discontinue our oldest models and concentrate instead on manufacturing sporty cars. We can also improve the success of our marketing campaigns by switching our advertising to the Youth Advertising agency, which has successfully promoted the country's leading soft drink.

Write a response in which you discuss the specific evidence needed to evaluate the strength of the argument and how the evidence would affect the argument.

The following appeared in a memorandum from the owner of Armchair Video, a chain of video rental stores.

Because of declining profits, we must reduce operating expenses at Armchair Video's ten video rental stores. Raising prices is not a good option, since we are famous for our special bargains. Instead, we should reduce our operating hours. Last month our store in downtown Marston reduced its hours by closing at 6:00 P.M. rather than 9:00 P.M. and reduced its overall inventory by no longer stocking any film released more than two years ago. Since we have received very few customer complaints about these new policies, we should now adopt them at all other Armchair Video stores as our best strategies for improving profits.

Write a response in which you consider possible alternative explanations for facts cited in the argument, and explain how your explanations effect the argument.

In each city in the region of Treehaven, the majority of the money spent on government-run public school education comes from taxes that each city government collects. The region's cities differ, however, in the value they place on public education. For example, Parson City typically budgets twice as much money per year as Blue City does for its public schools—even though both cities have about the same number of residents. It seems clear, therefore, that Parson City residents care more about public school education than do Blue City residents.

Write an essay in which you propose a series of questions to ask to further evaluate the argument that has been presented. Explain how the answers to these questions might affect the conclusion of the argument.

Breaking Down the Argument

There are three basic parts to any argument. They are:

The Conclusion: The conclusion is the main point of the argument. It is the thing the author is trying to prove. It is the author's recommendation or action point.

The Premises: If you identify the conclusion and ask, "Why?" the answer you get will be the premises. They are the facts or reasons the author uses to back up his or her conclusion.

Assumptions: You can't point to the assumptions because they're not there. The assumptions are the unstated conditions that attach the premise to the conclusion. There are hundreds of these.

When you begin to break down an argument, you will want to use the formal language of arguments. First identify the conclusion of the argument you've been given, and then identify the premises and then some of the missing or weaker assumptions.

There are a number of types of arguments that you will see often. Once you identify the type of argument being made, spotting the flaws is easy.

Causal

A causal argument assumes a cause-and-effect relationship between two events. Sales are down, for example, because of a change in demographics. To weaken a causal argument, you need only point out some other potential causes for a particular event. Perhaps sales are down because the overall economy is down, or because the product suddenly has competition. To strength a causal argument you need to show that other potential causes are unlikely.

Sampling or Statistical

In these arguments one group is assumed to be representative of a whole population. Members of the group that was surveyed all said that they prefer lite beer because it is less filling. To weaken this argument, you need to show that the group surveyed does not represent the whole population. Perhaps they surveyed beer drinkers at a restaurant, where they were also eating diner, rather than beer drinkers at a bar. Perhaps they surveyed at a liquor store right after lunch. To strengthen this argument you need to show that the sample population is, in fact, representative of the whole.

Analogy

Arguments by analogy claim that what is true for one group is also true for the other. Voters in Cleveland prefer one candidate, therefore voters in Detroit will too. To weaken these arguments you need to show that these two groups are not at all analogous. Perhaps Detroit is the hometown of the rival candidate; perhaps one candidate favors the auto industry and one does not. To strengthen these arguments you must show that the two groups are quite similar indeed.

The overall process for crafting your essay will be the same as it is for the Issue essay. Almost invariably you will end up criticizing the argument you have been given, although it is often a good strategy to use your conclusion to point out ways in which the argument could have been improved. Throughout your essay you want to use the language of arguments. This means naming conclusions as conclusions, sampling arguments as sampling arguments, premises as premises, and assumptions as assumptions.

Thinking

Begin by identifying your conclusion or conclusions and then the major premises upon which it/they rest. For each premise note the type of reasoning used (sampling, casual, etc.), and the like flaws associated with that type of reasoning. This is as much brainstorming as you will need.

Organizing

Rank these premises by the size of their flaws. Start with the most egregious and work your way down. The outline of your essay will look something like this:

The author's conclusion is Z. It is faulty and more research/information is needed before the suggested action is taken.

The first and biggest flaw is premise Y. It's possible that it is true, but it rests upon the following assumptions. Can we really make these assumptions? What about these alternative assumptions?

Even if we assume Y to be the case, there is premise X. Premise X draws an analogy between these two groups and assumes that they are interchangeable. Can we really make this assumption; what about these alternative assumptions ...?

Even if we assume X to be true, there is also W. W is a sampling argument, but the author not only has not proved the sample to be representative, but he/she points out that this might not be the case! Perhaps, as noted, blah, blah, blah.

In conclusion, this argument is incomplete and rests upon too many questionable assumptions. To improve this argument, the author needs to show A, B, and C: before the building is to be torn down, the company is to change tactics, the community is to devote resources, or the school is reorganize its curriculum.

Writing

Feel free to have fun with this essay. Reading essays can get pretty boring, and a smart, funny critique of a faulty argument can be a welcome break. You might say, "If I were the president of company X, I would fire my marketing director for wasting my time with such a poorly researched plan," or "What the marketing director of company X should have done is ...". It is okay to have personality as long as you get the Analysis-of-an-Argument job done at the same time.

For a more in-depth look at the techniques for the Argument essay and some sample essays, see *Cracking the New GRE*.

Here are some examples of the types of prompts you will see for your issue essay.

“One should not expect respect for disregarding the opinions of others. Only when every point of view is taken into consideration should people take action in the world.”

“An increased number of laws or rules, ironically leads to a diminished sense of morality and impoverished relations among people.”

“An idea alone, no matter how great, is meaningless unless it is put into practice.”

“The value of ancient works, no matter how great, cannot be accurately judged because modern standards are not relevant and ancient standards cannot be known.”

“When something is judged as ugly or lacking in style, it is only because it is being perceived by someone other than its target audience.”

“Truly innovative ideas tend to come from individuals, because groups tend to work towards consensus and the status quo.”

“It is far more important to define what you are for than what you are against.”

“Education consists of making errors.”

“The unknown is necessary.”

“Skill alone, no matter how great, does not guarantee a masterpiece.”

“To respect a symbol is to contribute power to a cultural institution, to worship a symbol is to bring about its eventual end.”

“Success means a greater ability to communicate one’s essence.”

“A student who wishes to succeed in business should study anything but business while in school, he or she will learn skills of business. However, the value of adding the additional perspectives gained by studying other fields of knowledge is too valuable to pass up.”

“Unexamined conservatism is far more dangerous than reckless change.”

“If a student can return home comfortably, a school has not done its job.”

Here are some examples of the types of prompts you will see for your argument essay.

The following appeared in a memorandum from the regional manager of the Taste of Italy restaurant chain:

“After the first month of service, the new restaurant in the Flatplains Mall, which uses the Chipless brand of wine glasses, has reported a far lower rate of breakage than our other restaurants that use the Elegance brand. Since servers and bartenders at all of our restaurants frequently report that breakage is a result of the type of wineglass, and the customers at the Flatplains Mall restaurant seem to like the Chipless style of glasses, we should switch all of our restaurants to the Chipless brand.”

The following appeared in an internal memo circulated amongst the partners of a small graphic design firm:

“When the economy was growing, there were more graphics jobs than there were designers and many designers could make more money working as independent contractors, than they could as salaried employees. As we too were growing and needed more designers, we were forced to pay higher salaries to recent design graduates than we had paid in the past. Now that the market is shrinking, we can save lots of money by cutting back the salaries of all designers on staff to match current market rates. Service sector companies and manufacturing companies have both been able to successfully cut wages in a down economy without harming production. We should too.”

The following appeared in a report to the board of a company that produces men’s sporting apparel:

“While national television advertising is increasingly expensive, it would cost roughly the same amount to reach the same number of people by buying print advertising space in various magazines. Since launching our newest TV ad campaign, sales have gone up significantly, but not in those markets which are served only by print ads. We should, therefore, increase our investment in TV ads and should not renew our magazine contracts once they are up.”

The following appeared in an internal memo circulated amongst the partners of a small design firm:

“We, the four partners of Max Design, have made the company what it is. When we are hired by a client, it is our taste and style that the client is paying for. In the last two years we have grown significantly and now have project managers handling many of our recent contracts. In my opinion, the work put forth by the teams led by the product managers is not as good as the work put forth when it was just the four of us. At other design firms of a similar size, the principals remain personally involved in all projects. Therefore, from now on, all decisions for all projects, no matter how minute, should be signed off by one of us.”

The following appeared in an email written by the head of market research division to the president of a major candy company:

“In the last four years the gross sales in the candy market have remained static, but ice cream, another confectionary product, has experienced huge increases in gross sales. Specifically, the growth of boutique ice cream brands specializing in unusual savory ice cream flavors such as pink peppercorn, basil, and ginger, has exploded. In response, we have tested some savory flavored candy chews at a number of national gourmet food fairs. The response to our free samples has been extremely enthusiastic. Therefore we should jump to the forefront of this trend and launch our savory candy chews nationally at all retail outlets.”

The following was a memorandum by the campaign manger for a state senate candidate:

“Contributors to nearly every major blog in the state, both democratic and republican, agree that a proposal to increase tolls on the major highways going through our state is a good thing. They don’t all agree that the increased revenue should go towards the same thing Some say we need more technology in the schools, others favor subsidizing insurance for the unemployed and independent contractors, and some say it should just be used to cut income tax. However, they all agree that the tolls should go up. Certainly this will cause more commuters to take public transportation, encourage businesses to ship by rail rather than truck, and save on road maintenance fees. Our chief competitor, who accepts major contributions from the trucking companies, opposes the toll increase. We should, therefore, come out strongly in favor of it.”

The following appeared on the op-ed page of a local newspaper:

“As violent crime rates have slowly inched up in our city, it is time for city officials to take a stand to protect citizens from harm. The first step is to gate and lock downtown parks after dark. Keys can be passed out to apartment owners and other local residents to ensure that they have continued access to these public spaces while protecting against people who are using the park for things other than the recreational activities for which these public spaces were designed. This approach has been taken in three of the five suburbs that surround this city and polls of both homeowners and police departments in all three report higher property values and lower crime rates. The city needs to act now before we reach a tipping point.”

More expert advice from

Give yourself the best chances for getting into the graduate school of your choice with The Princeton Review. We can help you achieve higher test scores, make informed choices, and make the most of your experience once you get there. We can also help you make the career move that will let you use your skills and education to their best advantage.

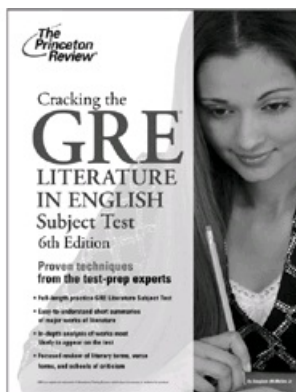
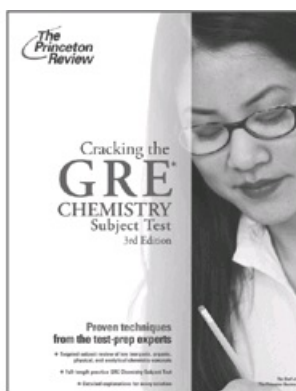
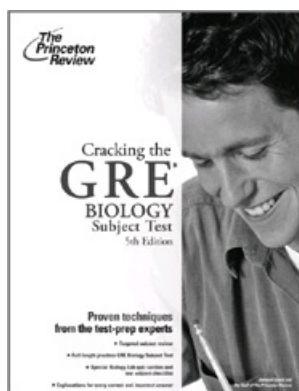
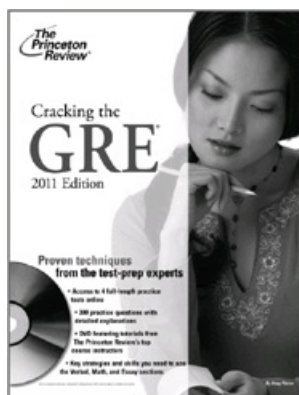

Cracking the New GRE, 2012 Edition
978-0-375-42818-0 • \$22.00/\$25.00 Can.

Cracking the New GRE with DVD, 2012 Edition
978-0-375-42819-7 • \$34.99/\$40.99 Can.

Essential GRE Vocabulary (flashcards)
978-0-375-42965-1 • \$18.99/\$23.99 Can.

Math Workout for the New GRE, 2nd Edition
978-0-375-42820-3 • \$19.99/\$22.99 Can.

Verbal Workout for the New GRE, 4th Edition
978-0-375-42821-0 • \$19.99/\$22.99 Can.

Crash Course for the New GRE, 4th Edition
978-0-375-42822-7 • \$9.99/\$10.99 Can.

www.ztcprep.com

978-0-375-42968-2 • \$19.99/\$22.99 Can.

Cracking the GRE Biology Test, 5th Edition
978-0-375-76488-2 • \$18.99/\$20.99 Can.

Cracking the GRE Chemistry Test, 3rd Edition
978-0-375-76489-9 • \$18.99/\$23.99 Can.

Cracking the GRE Literature Test, 6th Edition
978-0-375-42971-2 • \$18.99/\$23.99 Can.

Cracking the GRE Math Test, 4th Edition
978-0-375-42972-9 • \$18.99/\$23.99 Can.

Cracking the GRE Psychology Test, 8th Edition
978-0-375-42973-6 • \$18.99/\$23.99 Can.



Available everywhere books are sold and at PrincetonReviewBooks.com

Section	Number of Questions	Allotted Time
Analytic Writing (one section with two separately timed essays)	One “Analyze an Issue” essay and one “Analyze an Argument” essay	30 minutes per essay
Break		10 minutes
Verbal Reasoning (×2)	20 Questions	30 minute per section
Quantitative Reasoning (×2)	20 Questions	35 minutes per section
Experimental	20 Questions	30/35 minutes
Research	Varies	Varies

(Click [here](#) to return to text.)

More		Less
	2-1-1-F	
Questions in the first 10	Difficulty Level	Questions in the last five minutes
Passage that fit on one screen	Length	Passages for which you have to scroll
I can skim effectively	Skill Set	I get sucked into details and end up burning time
> 2 questions per passage	# of Questions	< 2 questions per passage

(Click [here](#) to return to text.)

More

Less

2-1-1-F

Difficulty Level

Length

Skill Set

of Questions

1. RTFQ

2. Make Q into Q
what/why

3. Find Proof

a. 5 ↑ 5 ↓

b. Lead Words

4. Answer Q in Own Words

5. POE

a. Extremes

b. Scope

c. Common Sense

(Click [here](#) to return to text.)

Main Idea:

Pros and cons of a unified assessment of the two halves of *Wuthering Heights*

Q: The author of the passage would be most likely to agree that an interpretation of a novel should

- ~~(A)~~ not try to unite heterogeneous elements in the novel
Half of the passage is about why this is a good thing!
- ~~(B)~~ not be inflexible in its treatment of the elements in the novel
Wording is ridiculous, but "be flexible," okay, that makes sense.
- ~~(C)~~ not argue that the complex use of narrators or of timeshifts indicates a sophisticated structure
Umm. Not sure, it's got to stay in for now.
- ~~(D)~~ concentrate on the those recalcitrant elements of the novel that are outside the novel's main structure
No, the author definitely didn't prescribe what someone should or shouldn't concentrate on.
- ~~(E)~~ primarily consider those elements of novelistic construction of which the author of the novel was aware
Common sense.

(Click [here](#) to return to text.)

Passage says: "Rigidity in any interpretation of this or any novel is always a danger."
and: "...is encouraged by the novel's sophisticated structure, revealed in its complex use of narrators and time shifts."

Q: The author of the passage would be most likely to agree that an interpretation of a novel should

~~(A)~~ not try to unite heterogeneous elements in the novel
Half of the passage is about why this is a good thing!

✓ (B) not be inflexible in its treatment of the elements in the novel
Wording is ridiculous, but "be flexible," okay, that makes sense.

PARAPHRASE!

✓ (C) not argue that the complex use of narrators or of timeshifts indicates a sophisticated structure
lead words
Umm. Not sure, it's got to stay in for now.

~~(D)~~ concentrate on the those recalcitrant elements of the novel that are outside the novel's main structure
No, the author definitely didn't prescribe what someone should or shouldn't concentrate on.

~~(E)~~ primarily consider those elements of novelistic construction of which the author of the novel was aware
Common sense.

PROOF!

(Click [here](#) to return to text.)

~~A~~ 29

B ✓ $\frac{1}{2}(10 + 9) + 11 = 18$

~~C~~ $\frac{1}{2}(10 - 11) = -\frac{1}{2}$

~~D~~ $40 + 5.5$

~~E~~ 13

$M = 10$

18

$M + 4 = 14$

$L + 11 = 7$

$L_{\text{now}} = 18$

(Click [here](#) to return to text.)

Left side used for set-up and answer choices

The right side is to be used for calculations scratch work

Terms labeled

All answer choices have been checked

~~A~~ 29

B ✓ $\frac{1}{2}(10 + 9) + 11 = 18$

~~C~~ $\frac{1}{2}(10 - 11) = -1/2$

~~D~~ $40 + 5.5$

~~E~~ 13

$M = 10$

18

$M + 4 = 14$

$L + 11 = 7$

$L_{\text{now}} = 18$

Work done on page when necessary

Target number circled

Line drawn underneath problem so that next problem can be started on clean space

(Click [here](#) to return to text.)

- A 29
- B ✓ $1/2 (10 + 9) + 11 = 18$
- C $1/2 (10 - 11) = -1/2$
- D $40 + 5.5$
- E 13

$M = 10$
 (18)

$M + 4 = 14$
 $L + 11 = 7$
 $L_{\text{now}} = 18$

<u>A</u>	A <u>B</u> C D	<u>B</u>
3	$n = 10$	3
-2	$n = 0$	-2
98	$n = 200$	98

half Wendy = 5
 $200 - 4 = 196$
 half Wendy = ~~$100 - 4$~~

$$\begin{array}{r} 98 \\ 2 \overline{) 196} \\ \underline{16} \end{array}$$

Roger	Adam	Vicken	Total	
10				
20				30
<u>30</u>	15	45	90	15
45				<u>45</u>
65				90

(Click [here](#) to return to text.)

Term	Definition	Examples
Integer	a “whole” number that does not contain decimals, fractions, or radicals; can be positive, negative, or zero	−500, 0, 1, 28
Positive	greater than zero	0.5, 25, $\frac{5}{3}$
Negative	less than zero	−72.3, $-\frac{7}{4}$, −2
Even	an integer divisible by two	−40, 0, 2
Odd	an integer not divisible by two	−41, 1, 3
Divisible	when a number divides into another number with nothing leftover	10 is divisible by 2, but not by 3.
Remainder	the “leftovers” when one number doesn’t divide evenly into another number	When 10 is divided by 3, the remainder is 1.
Divisor	a number that divides into another number	In the statement “24 divided by 6,” 6 is the divisor.
Sum	the result of adding	The sum of 3 and 4 is 7.
Difference	the result of subtracting	The difference between 7 and 2 is 5.
Product	the result of multiplying	The product of 5 and 7 is 35.
Quotient	the result of dividing	The quotient of 8 and 2 is 4.
Prime	a number that is only divisible by itself and 1; 1 is not considered prime (because 1 is itself); negative numbers and zero are not prime	2, 3, 5, 7
Consecutive	in a row, usually ascending	1, 2, 3, 4; −3, −2, −1, 0
Digits	0–9; the numbers on the phone pad	1, 2, 3, 4, 5, 6, 7, 8, 9, 0
Distinct	different	2 and 3 are distinct; 6.25 and 6.26 are distinct; 4 and 4 are not distinct.

(Click [here](#) to return to text.)

Decimal	Fraction	Percentage
0.25	1/4	25%
0.5	1/2	50%
0.75	3/4	75%
1.0	4/4	100%
3.75	15/4	375%
0.33	1/3	33%
0.66	2/3	66%
1.0	3/3	100%
1.66	5/3	166%
0.2	1/5	20%
0.4	2/5	40%
0.6	3/5	60%
0.8	4/5	80%
1.0	5/5	100%
1.2	6/5	120%
2.4	12/5	240%
0.125	1/8	12.5%
0.250	2/8	25%
0.375	3/8	37.5%
0.5	4/8	50%
0.625	5/8	62.5%
0.75	6/8	75%
0.875	7/8	87.5%
1.0	8/8	100%
1.125	9/8	112.5%
2.5	20/8	250%

(Click [here](#) to return to text.)

CHARITABLE ANNUAL DONATIONS TO CHARITY  **زنگنه**
 GROUP X

Employees of Company:	Years 1980–1990		Years 1980–2000	
	Average (mean) annual donation per employee	Greatest single annual donation by an employee	Average (mean) annual donation per employee	Greatest single annual donation by an employee
A	24.3	1,000	34.6	1,000
B	18.2	500	40.2	500
C	45.5	300	45.5	2,000
D	34.6	2,000	34.6	2,000
E	34.7	1,000	32.4	1,000
F	150.3	2,000	100.8	2,000
G	23.7	500	23.7	500
H	34.7	500	34.7	1,000
I	74.5	5,000	80.2	5,000
J	85.6	3,000	85.6	3,000
K	126.7	5,000	104.4	5,000
L	234.4	3,000	234.4	3,000
M	422.4	400	455.2	2,000

(Click [here](#) to return to text.)

CHARITABLE ANNUAL DONATIONS TO CHARITY  **زنگنه**
 GROUP X

Employees of Company:	Years 1980–1990		Years 1980–2000	
	Average (mean) annual donation per employee	Greatest single annual donation by an employee	Average (mean) annual donation per employee	Greatest single annual donation by an employee
A	24.3	1,000	34.6	1,000
B	18.2	500	40.2	500
C	45.5	300	45.5	2,000
D	34.6	2,000	34.6	2,000
E	34.7	1,000	32.4	1,000
F	150.3	2,000	100.8	2,000
G	23.7	500	23.7	500
H	34.7	500	34.7	1,000
I	74.5	5,000	80.2	5,000
J	85.6	3,000	85.6	3,000
K	126.7	5,000	104.4	5,000
L	234.4	3,000	234.4	3,000
M	422.4	400	455.2	2,000

(Click [here](#) to return to text.)

TOTAL BUDGET FOR THE CITY OF SPRINGFIELD
1992 AND 1998

INCOME SOURCES (IN THOUSANDS OF DOLLARS)

EXPENDITURES (IN THOUSANDS OF DOLLARS)

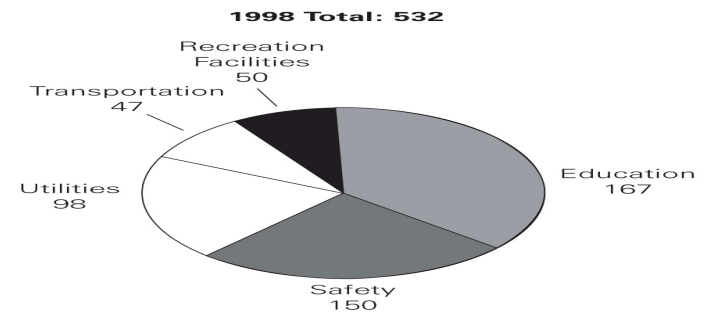
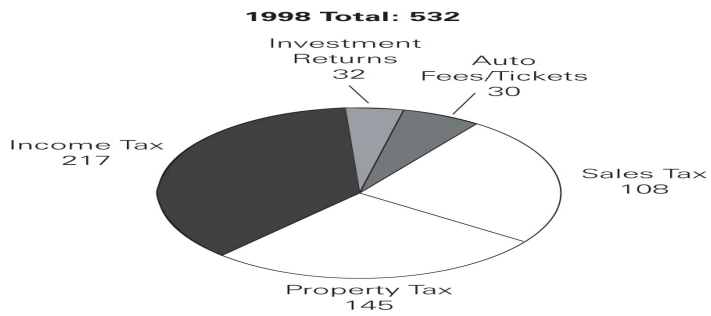
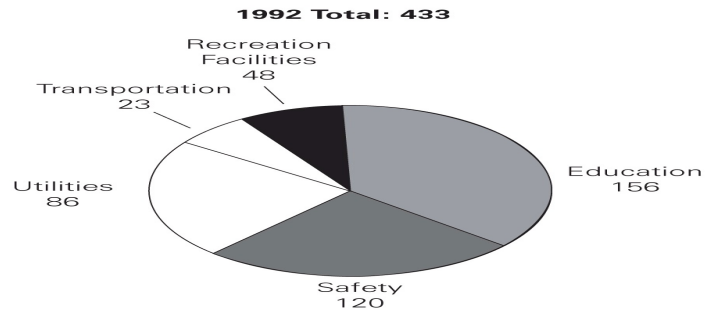
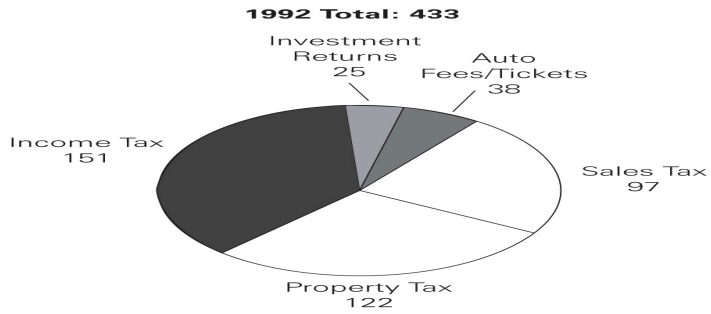

(Click [here](#) to return to text.)

MEMBERSHIP OF THE NORTH COUNTY AUTO
MECHANICS AND AUTO SALES ASSOCIATIONS
IN 1998

Auto Mechanics Association		Auto Sales Association
	Gender	
345	Male	500
464	Female	400
809	Total	900
	Age	
23	Youngest	25
68	Oldest	72
34	Average	44
	Number of Children	
125	0	209
223	1	126
204	2	98
117	3	85
54	4	132
52	5	128
34	6 or more	122
	Highest Education Level	
129	Some High School	185
286	High School Graduate	419
307	College Graduate	202
87	Advanced Degrees	94

(Click [here](#) to return to text.)

INCOME AND EXPENDITURES AT UNIVERSITY F IN 2004

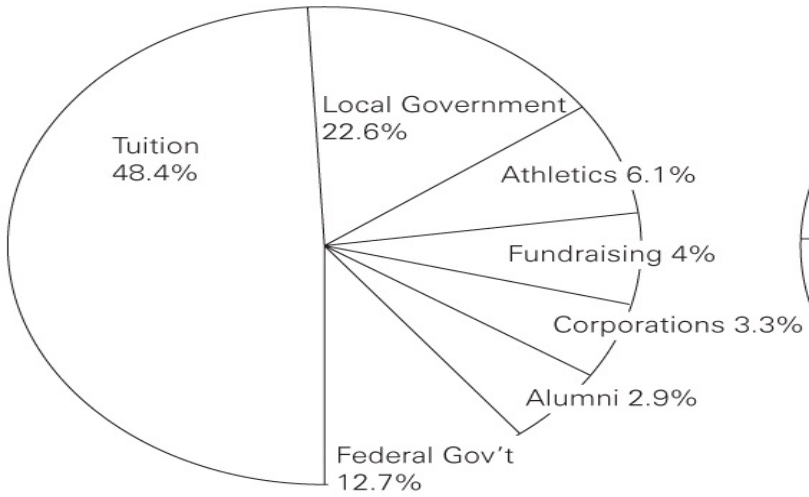

Total = \$120 million

Note: Drawn to scale.

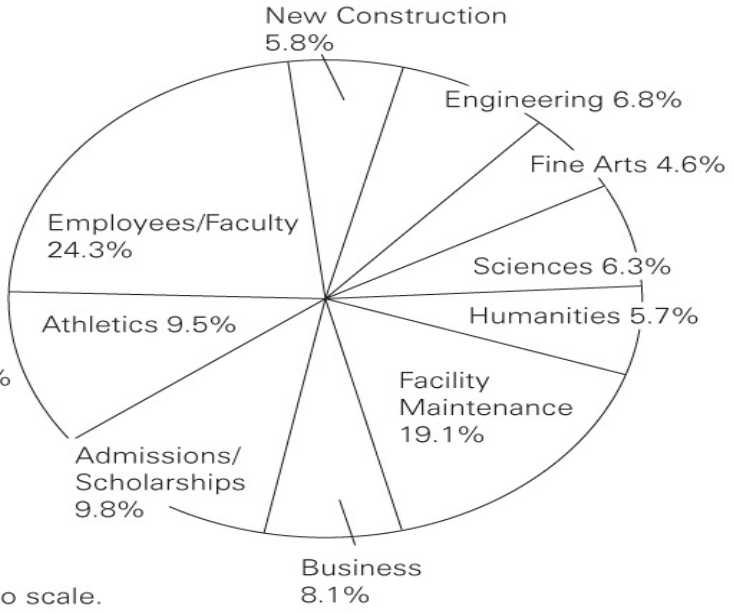

Total = \$120 million

(Click [here](#) to return to text.)

U.S. ENERGY SOURCES, 1979 AND 2004

---■--- 1979 Total for 1979 = 18,509
—●— 2004 Total for 2004 = 5,090

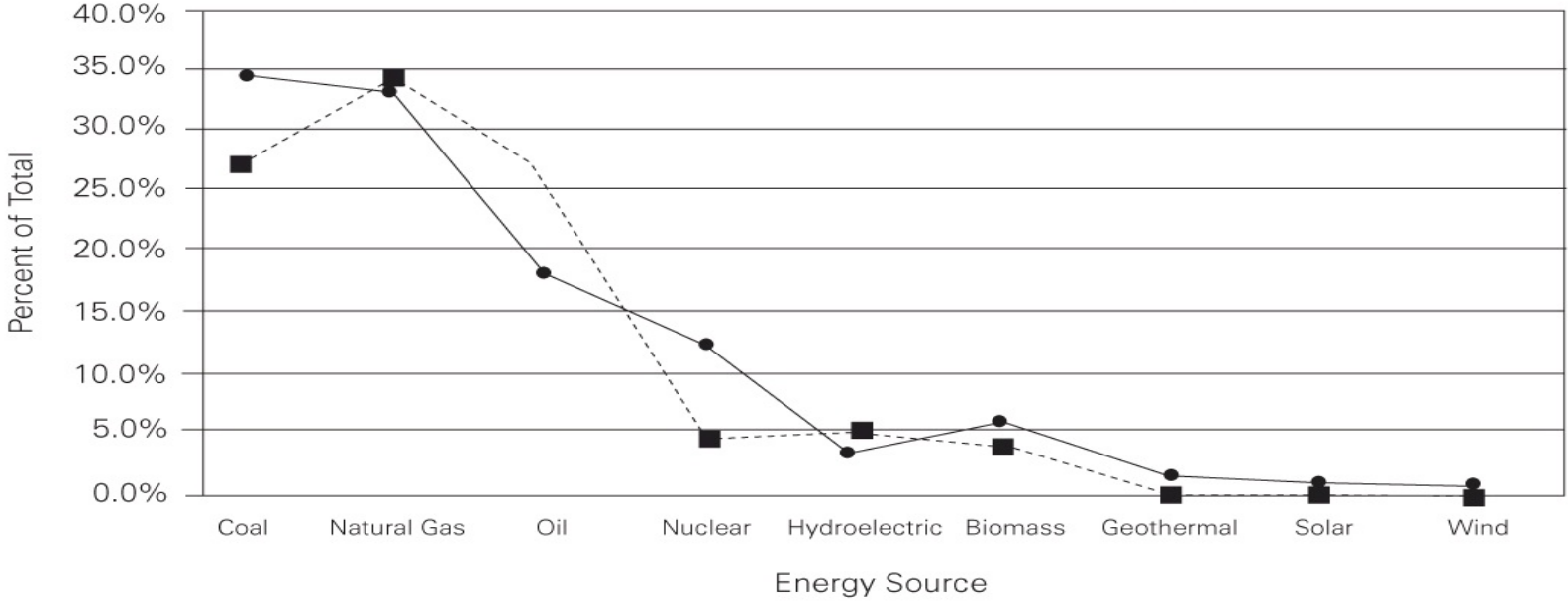

(Click [here](#) to return to text.)

PRODUCTION OF GOLF EQUIPMENT AND SUPPLIES
 WORLD PRODUCTION 1994-1998
 (values are in millions of dollars)

Country	1994		1995		1996		1997		1998	
	Value	Percent of Total	Value	Percent of Total	Value	Percent of Total	Value	Percent of Total	Value	Percent of Total
United States	2,691	62.3	2,975	63.7	3,248	65.1	3,424	65.1	3,438	63.2
Japan	678	15.7	752	16.1	793	15.9	831	15.8	876	16.1
South Korea	376	8.7	383	8.2	384	7.7	426	8.1	457	8.4
Germany	177	4.1	159	3.4	180	3.6	179	3.4	201	3.7
Great Britain	125	2.9	140	3.0	135	2.7	153	2.9	169	3.1
Canada	125	2.9	103	2.2	105	2.1	100	1.9	125	2.3
Argentina	99	2.3	103	2.2	95	1.9	100	1.9	114	2.1
Other Countries	49	1.1	55	1.2	50	1.0	47	0.9	60	1.1
Total	4,320	100	4,670	100	4,990	100	5,260	100	5,440	100

UNITED STATES PRODUCTION

1994
 Total: \$2,691 Million

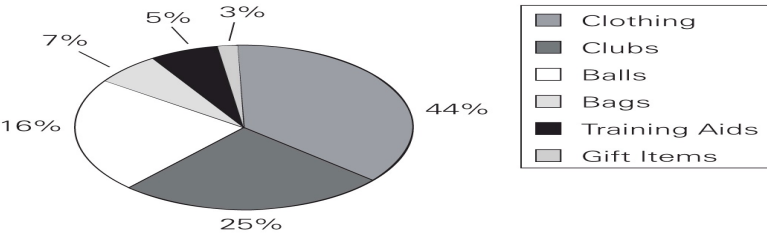

2001
 Total: \$3,770 Million

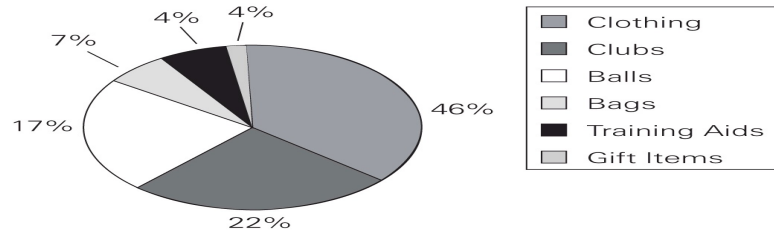

(Click [here](#) to return to text.)

The following charts represent April 2008 plant sales at the Friendly Nursery.

Sales by Growth Pattern

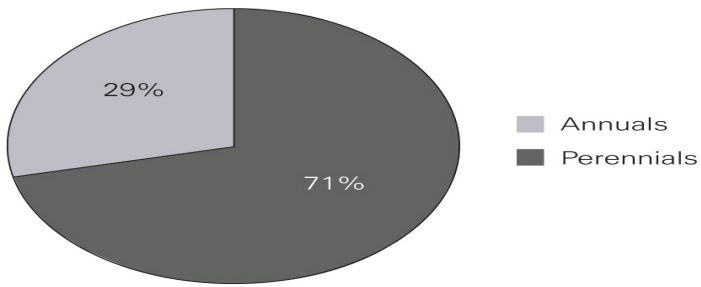

Sales of Annuals by Plant Type

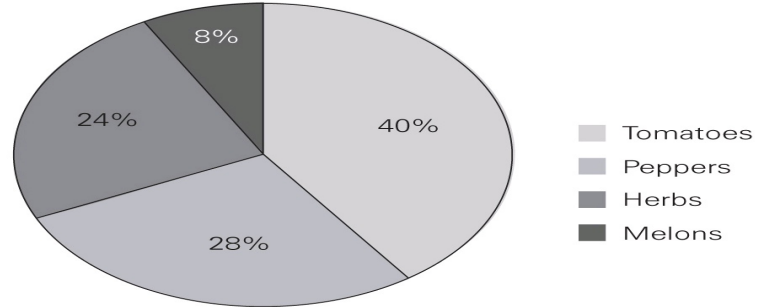

(Click [here](#) to return to text.)

PRODUCTION OF GOLF EQUIPMENT AND SUPPLIES
 WORLD PRODUCTION 1994-1998
 (values are in millions of dollars)

Country	1994		1995		1996		1997		1998	
	Value	Percent of Total	Value	Percent of Total	Value	Percent of Total	Value	Percent of Total	Value	Percent of Total
United States	2,691	62.3	2,975	63.7	3,248	65.1	3,424	65.1	3,438	63.2
Japan	678	15.7	752	16.1	793	15.9	831	15.8	876	16.1
South Korea	376	8.7	383	8.2	384	7.7	426	8.1	457	8.4
Germany	177	4.1	159	3.4	180	3.6	179	3.4	201	3.7
Great Britain	125	2.9	140	3.0	135	2.7	153	2.9	169	3.1
Canada	125	2.9	103	2.2	105	2.1	100	1.9	125	2.3
Argentina	99	2.3	103	2.2	95	1.9	100	1.9	114	2.1
Other Countries	49	1.1	55	1.2	50	1.0	47	0.9	60	1.1
Total	4,320	100	4,670	100	4,990	100	5,260	100	5,440	100

UNITED STATES PRODUCTION

1994
 Total: \$2,691 Million

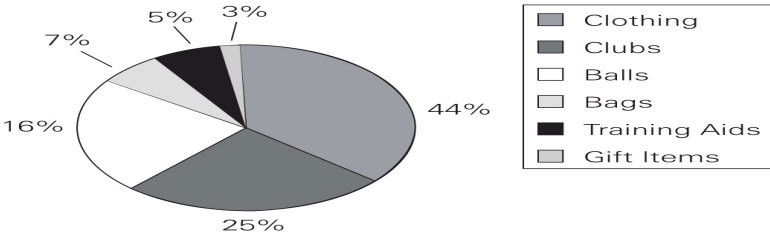

2001
 Total: \$3,770 Million

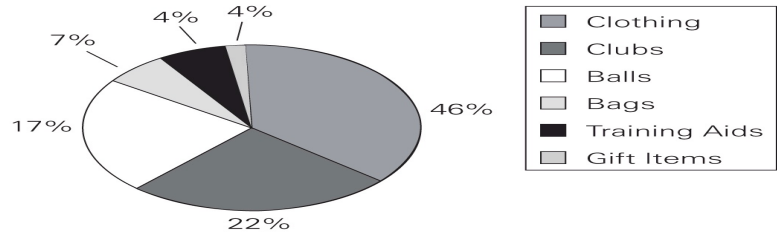

(Click [here](#) to return to text.)

U.S. ENERGY SOURCES, 1979 AND 2004

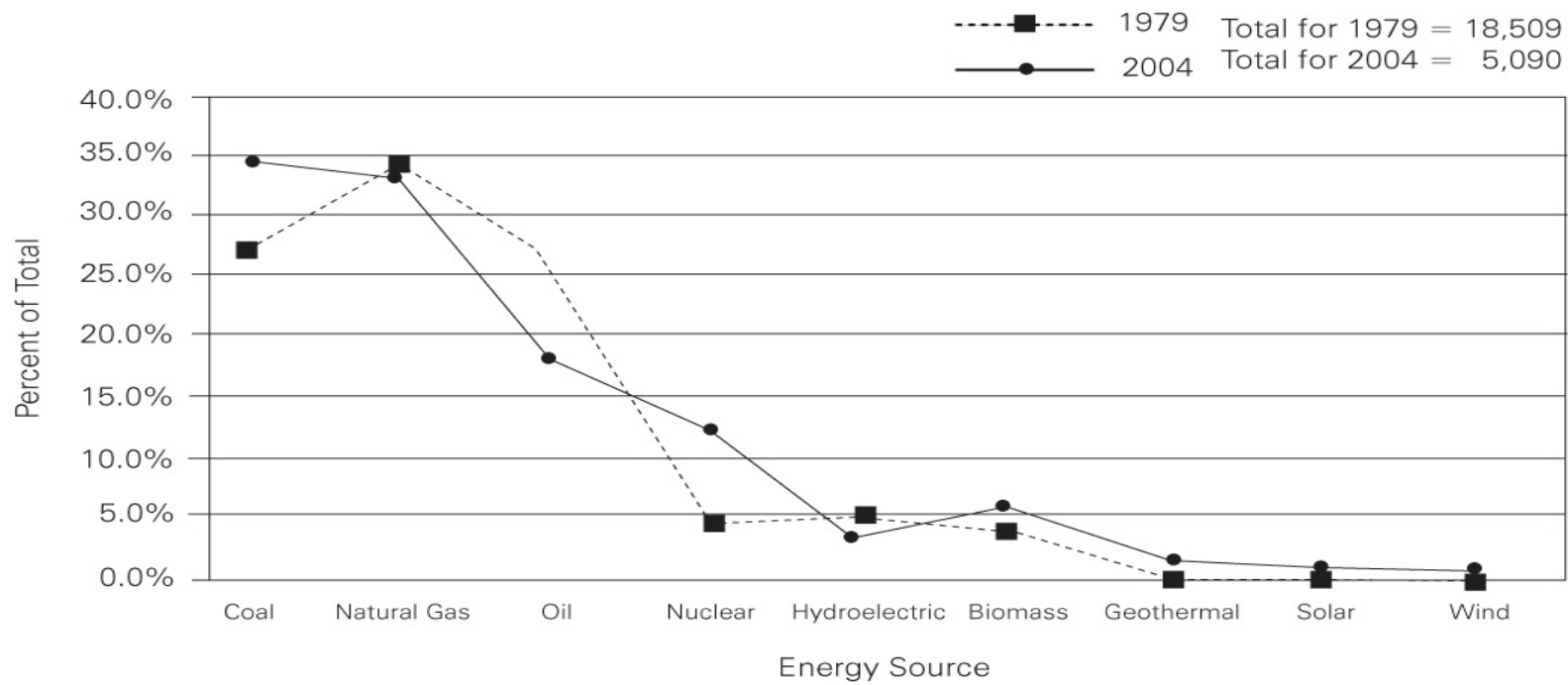

(Click [here](#) to return to text.)

MEMBERSHIP OF THE NORTH COUNTY AUTO MECHANICS AND AUTO SALES ASSOCIATIONS IN 1998

Auto Mechanics Association		Auto Sales Association
	Gender	
345	Male	500
464	Female	400
809	Total	900
	Age	
23	Youngest	25
68	Oldest	72
34	Average	44
	Number of Children	
125	0	209
223	1	126
204	2	98
117	3	85
54	4	132
52	5	128
34	6 or more	122
	Highest Education Level	
129	Some High School	185
286	High School Graduate	419
307	College Graduate	202
87	Advanced Degrees	94

(Click [here](#) to return to text.)

1,014

Practice Questions
for the New

GRE®

2nd Edition

REVISED
& UPDATED
FOR THE
NEW TEST

- 1 full-length GRE practice exam
- Fully updated verbal and math drills
- Hundreds of new practice questions covering the new question types
- Detailed, comprehensive explanations for every practice question

GRE is a registered trademark of Educational Testing Service, which does not sponsor or endorse this product.

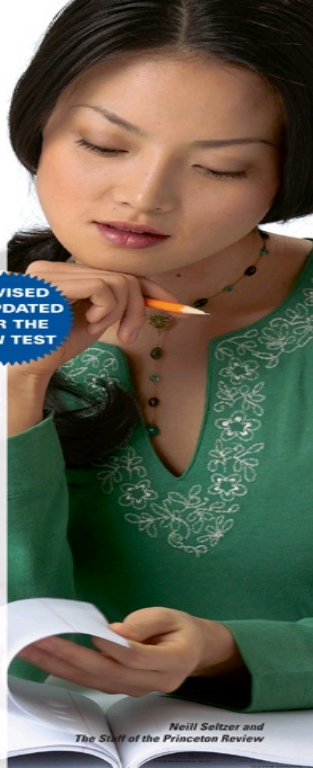

Neill Seltzer and
The Staff of the Princeton Review